

Explosion View of W797

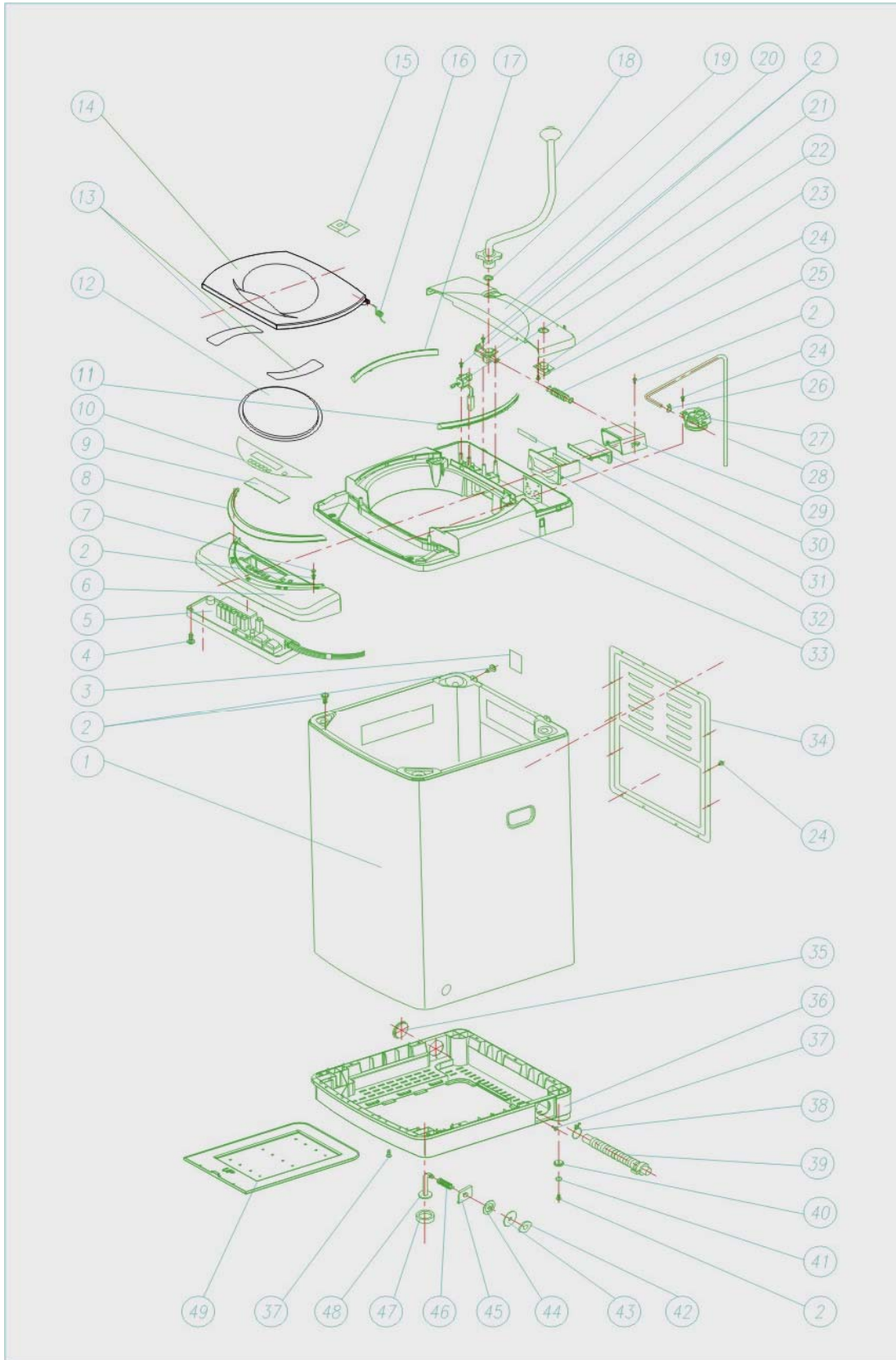

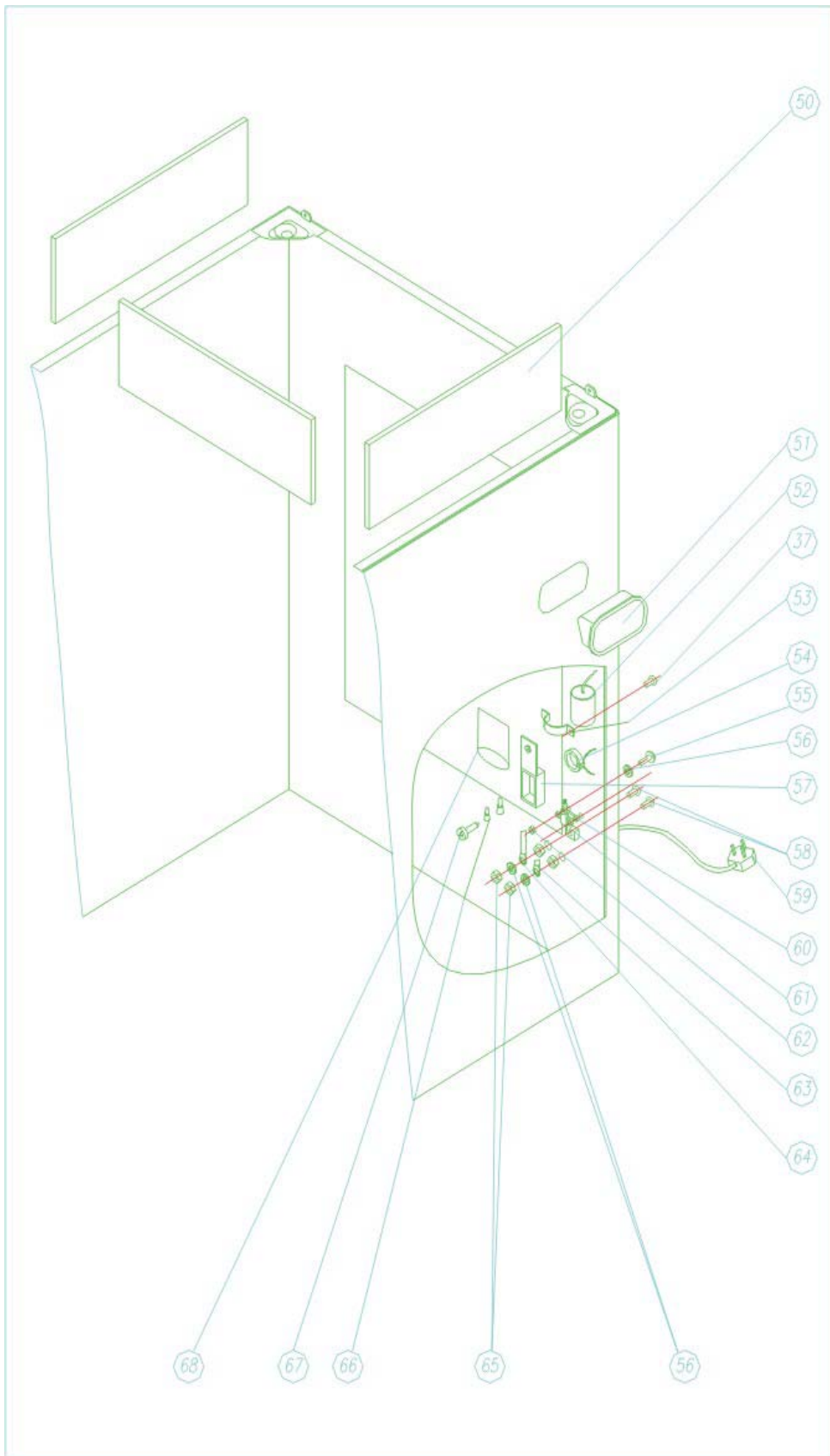

XQB526F Exploding Drawing(2)

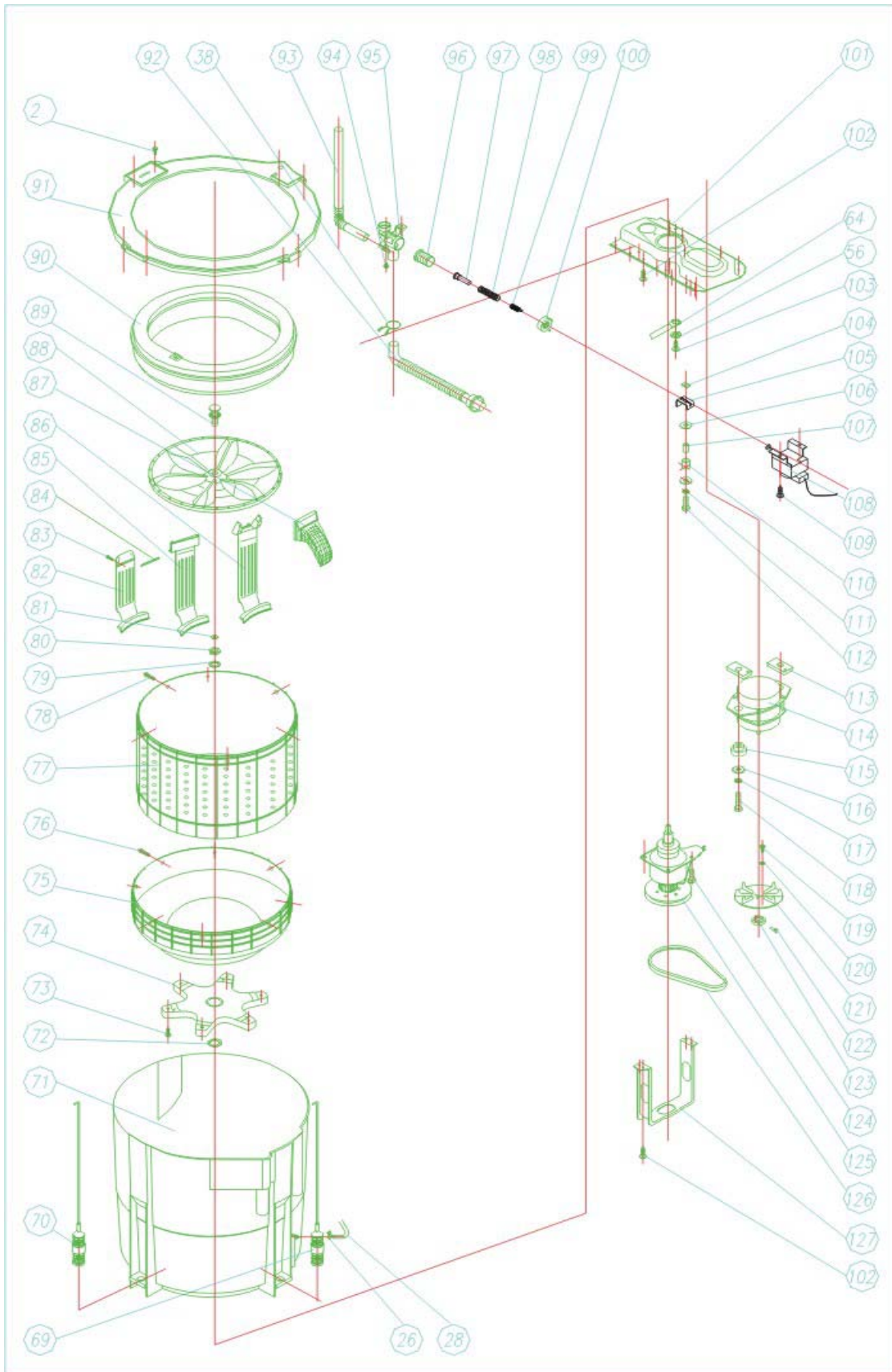

Parts List for W797

No.	Part Code	Description
1	XQB552.6.1	Cabinet
2	GB9074.18	Screw Assem ST4.2X16
3	XQB552-1	Name Brand
4	GB9074.18-88	Self Screw Assem ST4.2X19
5	XQB550.1.1-5	Micro Computer Assem
6	XQB550.1.1-1	Front Control Panel
7	XQB317-1	lid for long screw of top cover
8	XQB550.1.1-2	Front Fringing Line
9	XQB550.1.1-3	Perspective Window
10	XQB5526F.1.1-4	Decorative Film
11	XQB550.1-3	Right Fringing Line
12	XQB5526F.1.3-2	Perspective Lid
13	XQB5526F.1.3-5	Q526F Operating Instruction Paper
14	XQB5526F.1.3-3	Q526F lid
15	XQB36-16	Caution Label
16	XQB317.1-2a	Spring of Lid
17	XQB550.1-2	Left Fringing Line
18	XQB433.14.1	Assem of Inlet Hose
19		Seal Ring
20	XQB5526F.1.2-2	Q52 6F Back Lid
21	XQB4328.1.5	Water Inlet Valve
22	XQB550.1.6	Safety Switch
23	XQB760.1.1.1	Auto Power-off Switch
24	GB9074.18-88	Self Screw Assem ST4.2X9.5
25	XQB550.1-4	Water Inlet Elbow
26	XQB317.3-1	Spring Clamp
27	XQB550.1-5	Water Level Switch
28		Small Gas Pipe
29	XQB550.1.4-1	Water Inlet Box
30	XQB550.1.4-2	Separate Water Box
31	XQB550-5	Label for Detergent Box
32	XQB550-4	Detergent Box
33	XQB550.1-1	Top Cover
34	XQB31-25	Back Plate
35	XQB760.4-1	Cover for Drain Hole
36	XQB550.6-1	Base
37	GB9074.18-88	Self Screw Assem ST3.9X13
38	XQB31-10	Spring Clamp
39	XQB31.14.2	Assem of Drain Hose
40	XQB317.9-8	Stand Foot Mat
41	XQB317.9-9	Stand Foot Core
42	XQB31.9.3	Locked Knob
43	XQB31.9-15	Plastic Spacer for Moveable Foot
44	XQB317.9-5	Washer for Moveable Foot
45	XQB550.6-3	Mat Plate
46	XQB317.9-7	Adjustable Spring
47	XQB31.9-9a	Rubber Wrap for Cabinet Foot
48	XQB550.6-2	Cabinet Moveable Foot
49	XQB550-3	Base Plate
50	XQB526.8-1	Protective Block

51	XQB317.9-10	Handle
52	XQB31.9.2	Electrical Capacitor
53	XQB317.9.2	Capacitor Clamp
54	XQB436.17	inductive coil
55	GB9074.1	Screw Assem M4X16
56	GB93-87	Washer 4
57	XQB317-8	Connection Box
58	GB818-85	Screw M4X12
59	XQB317.9-13	Power Line
60	XQB317.9-14a	Spacer for Power Line
61	XQB317.9-18	Protective Wrap for Power Line
62	GB9074.18	Nut M4
63	XQB317.9-17	Grounding Wire
64	XQB31.10a	Grounding Wire
65	GB6170-86	Nut M4
66	XQB317-7	Small Protective Wrap for Connection
67	XQB317-9	Special Screw
68	XQB31-30a	Plastic Bag for Protective Wrap
69	XQB550.8	Back Suspension Member Assem
70	XQB550.7	Front Suspension Member Assem
71	XQB550.2-1	Outer Tub
72	XQB760.2-7	Inner Tub Washer
73	GB9074.22	Screw Assem ST4.8X25
74	XQB4298.4-9	Tray
75	XQB550.3-2	Inner Tub Bottom
76	XQB550.3-9	Inner Tub Body of Tightening Screw
77	XQB550.3-1	Inner Tub Body
78	GB9074.18-88	Screw Assem ST4.8X19-C-H
79	XQB31-7a	Press Ring for Inner Tub
80	XQB760.2-8	Nut for Inner Tub
81	XQB760.2-5	Washer for Impeller
82	XQB550.3-4	Short Spraying Channel
83	GB9074.18-88	Self Screw Assem ST4.2X9.5
84	XQB550.3-11	cover of spraying channel
85	XQB550.3-3	Spraying Channel
86	XQB550.3-5	Jet-Flow Channel
87	XQB550.3.1	Filter Easel
88	XQB550.4	Impeller Assem
89	XQB4298.18	Screw Assem for Impeller
90	XQB550.3.2	Balance Ring
91	XQB552.2-1	Outer Tub Ring
92	XQB550.2.2	Assem of Drain Elbow Hose
93	XQB550.2.4	Overflow Hose
94	GB9074.18	Screw Assem ST4.8X13

95	XQB760.2.4-1	Drain Valve House
96	XQB31.3.1-4	Rubber Wrap of Drain Valve
97	XQB31.3.1-2	Guide Wrap of Valve
98	XQB31.3.1-3a	Press Spring of Drain Valve
99	XQB4338.3.1-9	Pull Spring of Valve
100	XQB31.3.1-10	Nut for Drain Valve House
101	XQB550.2-3	Chassis
102	GB9074.22	Screw Assem ST6.3X25
103	GB818-85	screw M4X8
104	XQB31.3.1-8	Square Nut
105	XQB311.3.1-7	Connect Easel
106	GB97.1-85	Washer 6
107	XQB4338.3.1-6	Transmit Wrap
108	XQB311.12.1	drain motor
109	GB9074.22	Screw Assem ST6.3X25
110	XQB31.3.1-5a	Limited Wrap
111	GB859-87	Washer 6
112	GB5782-86	Bolt M6X3.5
113	XQB31-27(28)	Mat for Motor
114	XQB760.2.5-1	Motor
115	XQB31-18b	Insulation Mat for Motor
116	GB96-85	Washer 8
117	GB93-87	Washer 8
118	GB5782-86	Bolt M8X25
119	GB823-76	Screw M5X6
120	GB859-66	Washer 5
121	XQB31.11.2	Fan
122	XQB31.11-2a	Locked Screw
123	XQB52.2.1-1	Motor Pulley
124	GB5782-86	Screw M8X12
125	XQB4298.8	Clutch
126	XQB552.2-2	V-belt
127	XQB760.2-4	Protective Cover for Clutch