

IR304PE/S/PH



FEATURES

Magnetic induction technology provides fast and perfectly distributed heat

Incredible cooking control, with lightning fast high heat and very low lows

Four induction zones and 2-way bridging option accommodate different pan sizes

Cookware sensing guards against hot burners being left on

Dual convection oven for faster, more consistent cooking

Temperature probe lets you know when it's done

Cobalt blue porcelain interior

Red, black or brushed stainless control knobs

Self clean, delayed start, timed cook, Sabbath mode and more

10 cooking modes make meals easy

Rigorously tested in our U.S. manufacturing facilities for decades of use

Exceptional 24/7 support from our Customer Care team in Madison

ACCESSORIES

Bake stone kit (stone, rack and peel)

30" baking sheet

Front leg and rear caster covers

Dehydration kit (racks and door stop)

Full-extension easy glide oven rack

Stainless steel kickplate

Temperature probe and broiler pan

Set of three standard oven racks

Accessories available through an authorized Sub-Zero dealer.
For local dealer information, visit subzero-wolf.com/locator.



KNOB OPTIONS



TOP CONFIGURATION

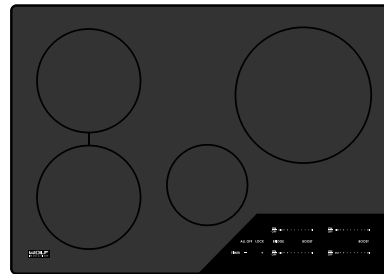

RANGETOP SPECIFICATIONS

- 1 - 1400 W Element
- 1 - 2100 W Element
- 1 - 2100 W Element with 3000 W Boost
- 1 - 2600 W Element with 3150 W Boost

PRODUCT SPECIFICATIONS

Model	IR304PE/S/PH
Dimensions	29 7/8"W x 35 7/8"H x 29 1/2"D
Oven 1 Interior Dimensions	25"W x 16 1/2"H x 19"D
Oven 1 Usable Capacity	2.8 cu ft
Oven 1 Overall Capacity	4.5 cu ft
Door Clearance	19 1/2"
Weight	325 lb
Electrical Supply	240 VAC, 60 Hz
Electrical Service	50 amp dedicated circuit

ELECTRICAL

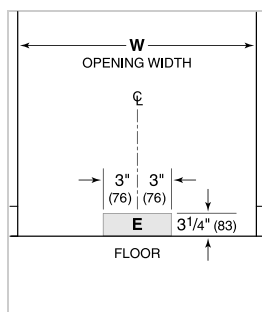

IMPORTANT NOTE:

Adjacent countertops must be at least 35 7/8" for flush installation to top of unit.

DIMENSIONS

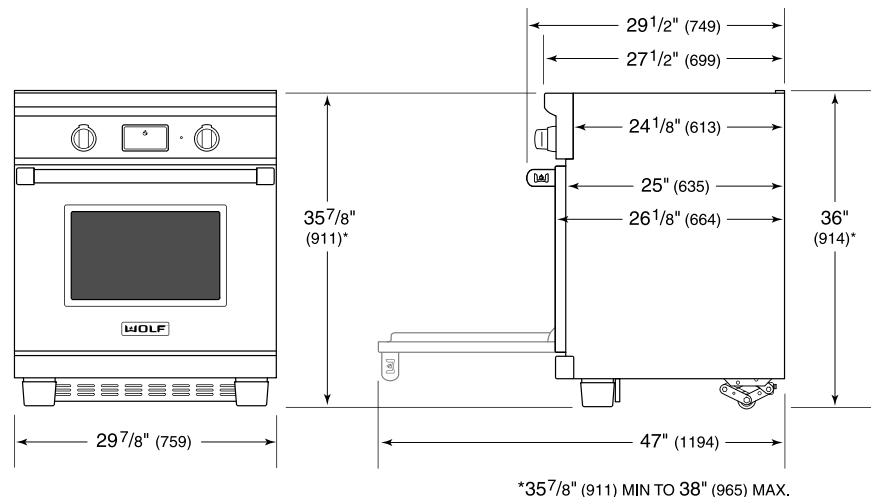

STANDARD INSTALLATION

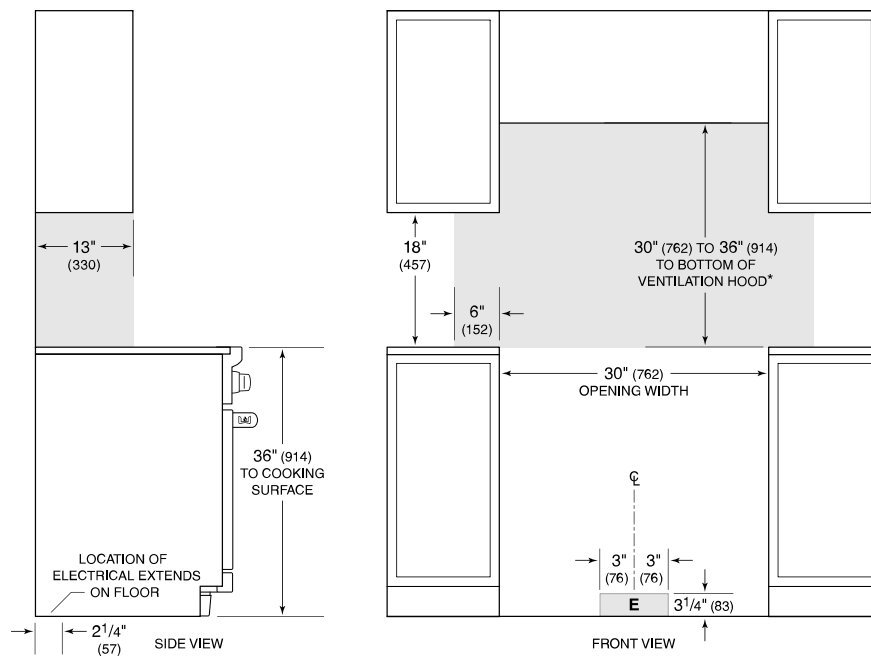

*Without ventilation hood, 36" (914) minimum clearance countertop to combustible materials.
 NOTE: Shaded area above countertop indicates minimum clearance to combustible surfaces, combustible materials cannot be located within this area.
 For island installation, 12" (305) minimum clearance back of range to combustible rear wall above countertop.