



Read and Save These Instructions
All Hoods Must Be Installed By A Qualified Installer

INSTALLATION INSTRUCTIONS

K SERIES LINER INSERT

Read All Instructions Thoroughly Before Beginning Installation

**WARNING - TO REDUCE THE RISK OF FIRE, ELECTRIC SHOCK,
OR INJURY TO PERSONS, OBSERVE THE FOLLOWING:**

- A. Installation work and electrical wiring must be done by qualified person(s) in accordance with all applicable codes and standards, including fire-rated construction. Switch power off at service panel and lock the service disconnecting means to prevent power from being switched on accidentally during installation.**
- B. When cutting or drilling into wall or ceiling, do not damage electrical wiring and other hidden utilities.**
- C. Ducted fans must always be vented to the outdoors.**
- D. Sufficient air is needed for proper combustion and exhausting of gases through the flue (chimney) of fuel burning equipment to prevent back drafting. Follow the heating equipment manufacturer's guideline and safety standards such as those published by the National Fire Protection Association (NFPA), and the American Society for Heating, Refrigeration and Air Conditioning Engineers (ASHRAE), and local code authorities.**
- E. ASHRAE residential ventilation standard 62.2 limits exhaust fans (total) to a maximum of 15 CFM per 100 square feet of occupiable space, unless a back drafting test is performed or make-up air is provided. Consult a local HVAC engineer for make-up air evaluation.**

**WARNING - TO REDUCE THE RISK OF FIRE, USE ONLY METAL
DUCTWORK**

Vent-A-Hood®

Ducting Do's and Don'ts

NEVER restrict the duct size. The K250 blower unit requires 7" round duct or equivalent (32.5 square inches). Using Vent-A-Hood transitions (back page) will ensure proper efficiency.

Blower	Duct Size	Sq. Inch Area
K250	3 1/4" x 10" Rectangular or equivalent	32.5"

Do not use flexible or corrugated duct. This type of duct will restrict airflow and reduce performance. Only use smooth, galvanized, metal duct. Observe local codes regarding special duct requirements and placement of duct against combustibles. Make the duct run as short and as straight as possible with as few turns as possible. Avoid sharp-angled turns. Instead, use smooth, gradual turns such as adjustable elbows or 45 degree angled turns. For duct runs over 20 feet, increase the duct diameter by one inch for every ten feet of duct. A 90 degree elbow is equal to 5 feet of duct. Using Vent-A-Hood roof jacks or wall louvers (back page) will ensure proper efficiency. Airflow must not be restricted at the end of the duct run. Do not use screen wire or spring-loaded doors on wall louvers or roof jacks. Do not terminate venting into an attic or chimney. Where possible, seal joints with duct tape. The hood must be ducted to the outdoors without restrictions.



Smooth Duct

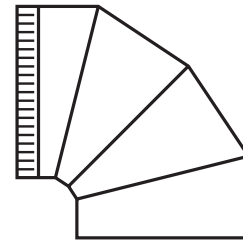

Smooth Gradual Turn

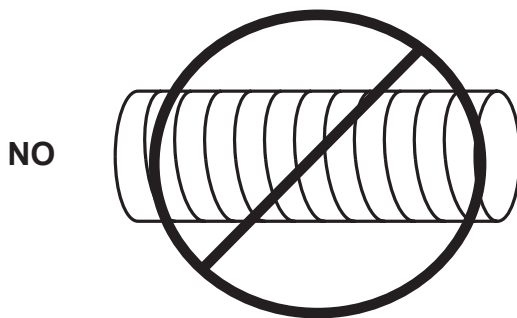

Flexible Duct

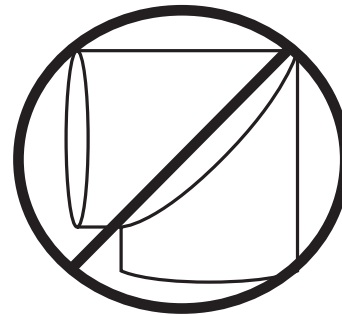

Sharp Angled Turns

Vent-A-Hood®

Installation Details

- 1) Read all instructions thoroughly before beginning installation.
- 2) When installing the KHSLD wall mount liner, it is recommended that the bottom edge of the liner be located no more than 21" - 24" above the cooking surface for optimum performance.

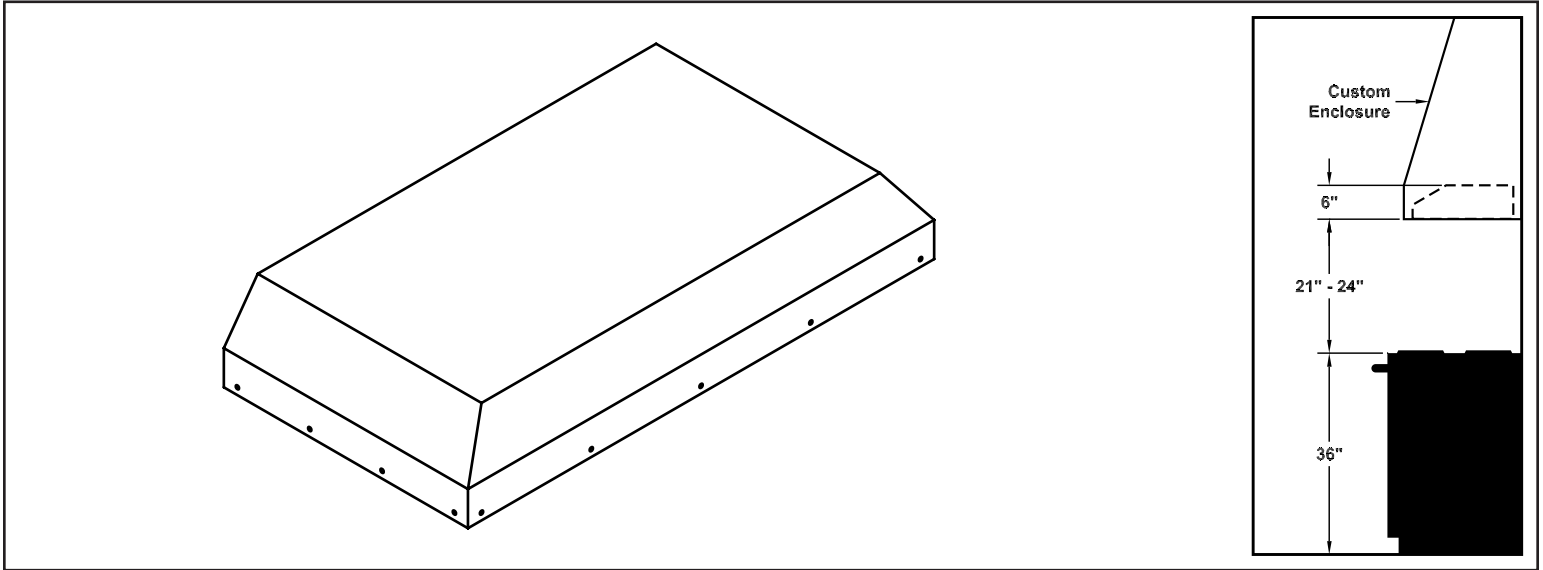

- 3) Determine whether the liner will discharge horizontally or vertically. The liner is shipped to discharge vertically but is easily converted to horizontal discharge by exchanging the discharge adapter on top of the liner (4 screws) with the discharge cover on the back of the liner (2 screws). Use duct tape to seal the discharge adapter and the discharge cover to the liner.
- 4) IF THE LINER IS TO BE "BACK VENTED", PROCEED DIRECTLY TO STEP 5.

Install the duct from the outside of the home down to the location of the exhaust outlet on the top of the liner allowing room for the VP521 transition (if applicable). If a VP521 transition is used, install the duct down to the location of the transition outlet plus 1". This will allow the transition to engage 1" inside of the duct. Consult the connection diagram (below) for further details on exhaust outlet placement.

Use duct tape to seal all joints. A complete listing of available Vent-A-Hood ducting materials is provided on the back page of this instruction sheet.

Transition height: 3 1/4" x 10" duct will connect directly to the exhaust outlet of the hood. Optional VP521 transition to 7" round (sold separately) is 7 1/2" tall.

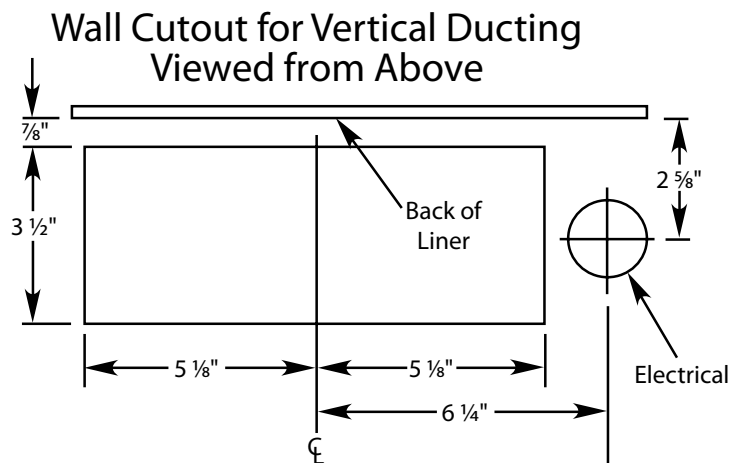

- 5) Remove the liner from the packaging and place underneath the enclosure (previously installed).

Vent Hood®

Installation Details Continued

Warning: Make sure power is off and locked at the service disconnecting means on the service panel during installation.

- 6) Determine whether the electrical wire will enter from the top or the back of the liner. Remove the electrical enclosure cover (1 screw) and the top or back electrical knockout from the liner. Install an appropriate 1/2" UL listed electrical wire clamp through the electrical knockout. Install electrical wiring from the electrical panel to the liner location.

Model	Volts	Amps	Hz	RPM	CFM SP@0.0"	Equivalent CFM*	CFM SP@0.1"	CFM SP@0.2"	CFM SP@0.3"	Minimum Round Duct Size	Sones#
K250 (Top Vent)	115	3.2	60	1550	250	375	223	220	190	7" (38 in. ²)	7.4
K250 (Back Vent)	115	3.2	60	1550	220	330	196	194	167	7" (38 in. ²)	7.4

* Because the Magic Lung® blower uses centrifugal filtration rather than conventional baffle or mesh filters, the Magic Lung® blower can handle cooking equipment with higher cubic feet per minute (CFM) requirements and can deliver equivalent CFM much more efficiently than other than other filtration systems. When comparing the Magic Lung® with other blower units made by other manufacturers, use the "Equivalent CFM".

Ratings in accordance with the Standard Test Code by the Energy Systems Laboratory of the Texas Engineering Experiment Station.

- 7) Insert the electrical wire through the electrical wire clamp allowing 3"- 4" of wire inside the enclosure for hookup. Tighten the electrical wire clamp.
- 8) From inside the liner, using UL listed wire nuts, attach the "neutral" wire to the white lead, the "hot" wire to the black lead, and the ground wire to the green lead inside the junction box. Replace the electrical cover previously removed in Step 6.

Warning: Do not operate hood without proper ground connection.

- 9) FOR BACK VENTING APPLICATIONS ONLY. IF YOU ARE NOT BACK VENTING, PROCEED DIRECTLY TO STEP 12.

Note: Wall studs may interfere with back venting installations. Additional framing may be required. It is necessary to cut a duct access hole in the wall prior to installing the liner. Starting 1" above the bottom edge of the enclosure, cut a hole 5" high x 12 1/8" wide (see diagram at right).

Wall Cutout for Horizontal Ducting Viewed from Front

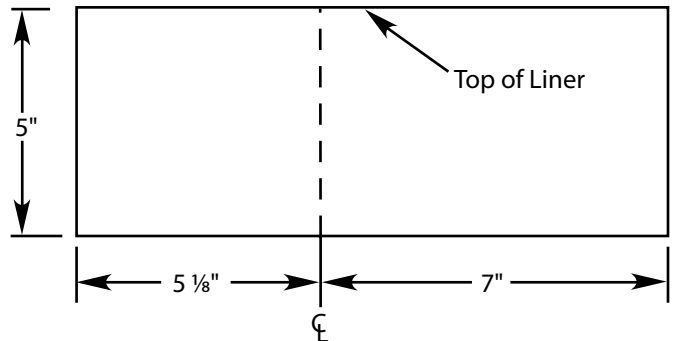

- 10) While guiding the wires, lift the liner up into the enclosure flushing the bottom edges of the liner and the enclosure. Note: The liner must be tilted to allow the exhaust collar on the back of the liner to enter the wall cutout. Screw the liner (wood screws provided) to the enclosure through the holes along the bottom edge of the liner. Wood strips may be necessary to fill any gaps between the opening and the liner if the opening in the wood surround is larger than the liner.

- 11) Install the duct from the outside of the home to the exhaust collar on the liner. Note: The duct work must fit inside the exhaust collar. Where possible, use duct tape to seal joints. SKIP STEP 12. PROCEED DIRECTLY TO STEP 13.

- 12) While aligning the duct and guiding the wires, lift the liner up into the enclosure flushing the bottom edges of the liner and the enclosure. Duct should connect together as the liner is raised into place. Note: Unless using the VP521 transition, the duct work must fit inside the exhaust collar. If using the VP521, 7" round duct should be placed with the non-crimped end on the outside of the collar of the VP521 exhaust outlet. Screw the liner (wood screws provided) to the enclosure through the holes along the bottom edge of the liner. Wood strips may be necessary to fill any gaps between the opening and the liner if the opening in the wood surround is larger than the liner.

- 13) Refer to the Owner Maintenance Guide Operating Instructions for proper hood operation. Test all blower and light functions to ensure they are operating properly.

VENTING

Vent-A-Hood®

ACCESSORIES

WALL LOUVER

MODEL	DESCRIPTION
VP526	6" Round
VP527	7" Round
VP528	8" Round

WALL LOUVER

MODEL	DESCRIPTION
VP554	10" Round

WALL LOUVER

MODEL	DESCRIPTION
VP555	12" Round

RECTANGULAR WALL LOUVER

MODEL	DESCRIPTION
VP538	6" x 8-1/2"
VP560	3-1/4" x 10"

LOW PROFILE ROOF JACK (MAXIMUM 4/12 PITCH)

MODEL	DESCRIPTION
VP539	6" Round
VP540	7" Round
VP541	8" Round

LOW PROFILE ROOF JACK (MAXIMUM 4/12 PITCH)

MODEL	DESCRIPTION
VP552	10" Round
VP553	12" Round

LOW PROFILE ROOF JACK (MINIMUM 4/12 PITCH)

MODEL	DESCRIPTION
VP539-HP	6" Round
VP540-HP	7" Round
VP541-HP	8" Round

LOW PROFILE ROOF JACK (MINIMUM 4/12 PITCH)

MODEL	DESCRIPTION
VP552-HP	10" Round
VP553-HP	12" Round

ADJUSTABLE ELBOW

VP513 - 8 1/2"
VP514 - 9 9/16"
VP515 - 10 5/8"

MODEL	DESCRIPTION
VP513	6" Round
VP514	7" Round
VP515	8" Round

BACK/SIDE VENT ELBOW

MODEL	DESCRIPTION
VP561	8" to 6" x 8-1/2"

3 1/4" x 10" BACK VENT ELBOW

MODEL	DESCRIPTION
VP559	3-1/4" x 10"

3 1/4" x 10" TO 7" TRANSITION

MODEL	DESCRIPTION
VP521	3-1/4" x 10 to 7"

MULTI-BLOWER TRANSITION

VP562 - 17 1/2"
VP563 - 16 1/2"
VP562 - 23 1/4"
VP563 - 30 1/2"

MODEL	DESCRIPTION
VP562	6" & 8" to 10"
VP563	8" & 8" to 12"

M1200 STANDARD TRANSITION

MODEL	DESCRIPTION
VP566	M1200 Transition

STANDARD ISLAND TRANSITION

MODEL	DESCRIPTION
VP565	5" x 16" to 8" Rnd

CLUSTER BLOWER TRANSITION

MODEL	DESCRIPTION
VP564	8" & 8" to 12"

OFFSET L & R TRANSITION FOR ISLAND BLOWERS

MODEL	DESCRIPTION
VP542	Top Left
VP543	Top Right

SIDE VENT TRANSITION L & R FOR ISLAND BLOWERS

MODEL	DESCRIPTION
VP544	Side Left
VP545	Side Right

OFFSET KIT - ROUND

MODEL	DESCRIPTION
VP529	6" Rnd to 7" Rnd

OFFSET KIT - RECTANGULAR

MODEL	DESCRIPTION
VP550	6" to 3-1/4" x 10"

"Y" TRANSITION

MODEL	DESCRIPTION
VP517	8" & 8" to 12"
VP518	6" & 8" to 12"
VP551	6" & 8" to 10"

ROUND DUCT PIPE

MODEL	DESCRIPTION
VP500	6" Round
VP501	7" Round
VP502	8" Round

3 1/4" RECTANGULAR DUCT PIPE

MODEL	DESCRIPTION
VP504	3-1/4" x 10"
VP505	3-1/4" x 12"
VP506	3-1/4" x 16"

6" RECTANGULAR DUCT PIPE

MODEL	DESCRIPTION
VP507	6" x 8-1/2"