



Proven Commercial Performance for Your Home™

VIKING PROFESSIONAL TURBOCHEF® SPEEDCOOK DOUBLE OVEN





THE VIKING PROFESSIONAL TURBOCHEF® SPEEDCOOK OVEN IS DESIGNED FOR YOU.

The Viking Professional TurboChef Speedcook oven combines proven commercial technology with renowned Viking design to create a superior oven specifically for today's home chef. From innovative controls to amazing cooking performance, this oven gives you more freedom.

Steamed asparagus – perfectly al dente – in 45 seconds. A rack of lamb in 4 minutes. A 12-pound Thanksgiving turkey in 42 minutes. From family favorites to gourmet dinners, the TurboChef Speedcook oven enables you to cook fresh, delicious food up to 15 times faster than conventional methods with the flavor and quality endorsed by four-star chefs. Meats are caramelized, moist, and tender. Baked goods are golden and flaky, and vegetables come out fresh, crisp, and succulent.

Whether it's dinner on a busy Wednesday night, a dinner party for friends on Saturday night, or a once-a-year special occasion, the TurboChef Speedcook oven gives you the freedom to be the cook you want to be more often.





ROASTED TURKEY

12 lbs. in 42 minutes

CONVENTIONAL TIME	04:00:00		_____
TURBOCHEF TIME	00:42:00		_____ (83% FASTER)



STEAMED ASPARAGUS

20 stalks in 45 seconds

CONVENTIONAL TIME	00:10:00		_____
TURBOCHEF TIME	00:00:45		_____ (93% FASTER)



SCALLOPS ON ROSEMARY SKEWERS

10 skewers in 4½ minutes

CONVENTIONAL TIME	00:15:00		_____
TURBOCHEF TIME	00:04:30		_____ (70% FASTER)



CHOCOLATE SOUFFLÉ

8 6-ounce soufflés in 5 minutes

CONVENTIONAL TIME	00:20:00		_____
TURBOCHEF TIME	00:05:00		_____ (75% FASTER)

KEY FEATURES

TOP OVEN:

SPEEDCOOK OVEN

- Utilizes patented Airspeed Technology™
- Easy-to-use, menu driven control system
- Self-clean function

VIEWING WINDOW

- 23.25"W. x 9"H.
- Triple pane window

CAVITY INTERIOR

- Large 2.5 cu. ft. capacity—holds up to a 26 lb. turkey
- Black porcelain coating
- 2 rack positions
- 1 standard rack
- Hydraulic damper on door hinges for smoother opening and closing
- Dual halogen lights

COMMERCIAL PERFORMANCE

- 7 Speedcook modes: Bake, Roast, Broil, Air-Crisp, Toast, Dehydrate, and Favorites
- "Favorites" stores your custom recipes
- Advanced mode for manual adjustments
- Microwave, defrost, and standard convection bake modes

EXCLUSIVE COLOR FINISHES

- 7 finishes: Stainless Steel (SS), Black (BK), White (WH), Apple Red (AR), Graphite Gray (GG), Cobalt Blue (CB), Burgundy (BU)

EASY-TO-USE DISPLAY

- State-of-the-art color interface controls both ovens
- Over 500 cooking profiles
- Built-in, on-demand help and information
- Make mid-course cooking adjustments
- "Favorites" and "Last 10 items cooked" for easy recall
- Oven light switch



BOTTOM OVEN:

CONVECTION OVEN, PROOFING OVEN, WARMING OVEN

- 4 heating elements provide uniform cooking—convection, inner broiler, outer broiler, and bake
- Self-clean function
- 5 cook modes: Bake, Roast, Broil, Convection Bake, Convection Roast,
- Warming setting
- Proofing setting

VIEWING WINDOW

- 23.25"W. x 11"H.
- Triple pane window

CAVITY INTERIOR

- Large 3.8 cu. ft. capacity
- Black porcelain coating
- 6 rack positions
- 2 racks – 1 standard rack and 1 TruGlide™ Full Extension Rack
- Dual halogen lights
- Recessed double broil element for max capacity
- Temperature probe ensures perfect baking/roasting of meats
- Hydraulic damper on door hinges for smoother opening and closing



SPECS AND DIMENSIONS

PRODUCT DIMENSIONS	
Description	V DOT730
Product Width Outside Cabinet	30-1/6" (76.4 cm)
Product Height Outside Cabinet	50-7/8" (129.2 cm)
Product Depth Outside Cabinet	Cabinet to front of display/ doors: 3-1/8" (7.9 cm) with bottom door open: 20-1/2" (52.1 cm)
Cutout Width	28-1/2" (72.4 cm)
Cutout Height	50-5/8" (128.6 cm)
Cutout Depth	24" (60.9 cm)
Electrical Requirements	4-wire ground, 240VAC, 50 amp electrical connection. Unit is equipped with No. 10 ground wire in conduit. Should be fused separately.
Max. Amp Usage	45.0 amps – 208* or 240 voltage
Oven Interior Width	24" (61.0 cm)
Oven Interior Height	Upper Oven: 12" (30.5 cm) Lower Oven: 15-1/2" (39.4 cm)
Oven Interior Depth	Upper Oven: 15-3/8" (39.1 cm) Lower Oven: 17-1/2" (44.5 cm)
Oven Volume (Overall AHAM)	Upper Oven: 2.5 cu. ft Lower Oven: 3.8 cu. ft.
Approximate Shipping Weight	490 lbs. (223 kg)

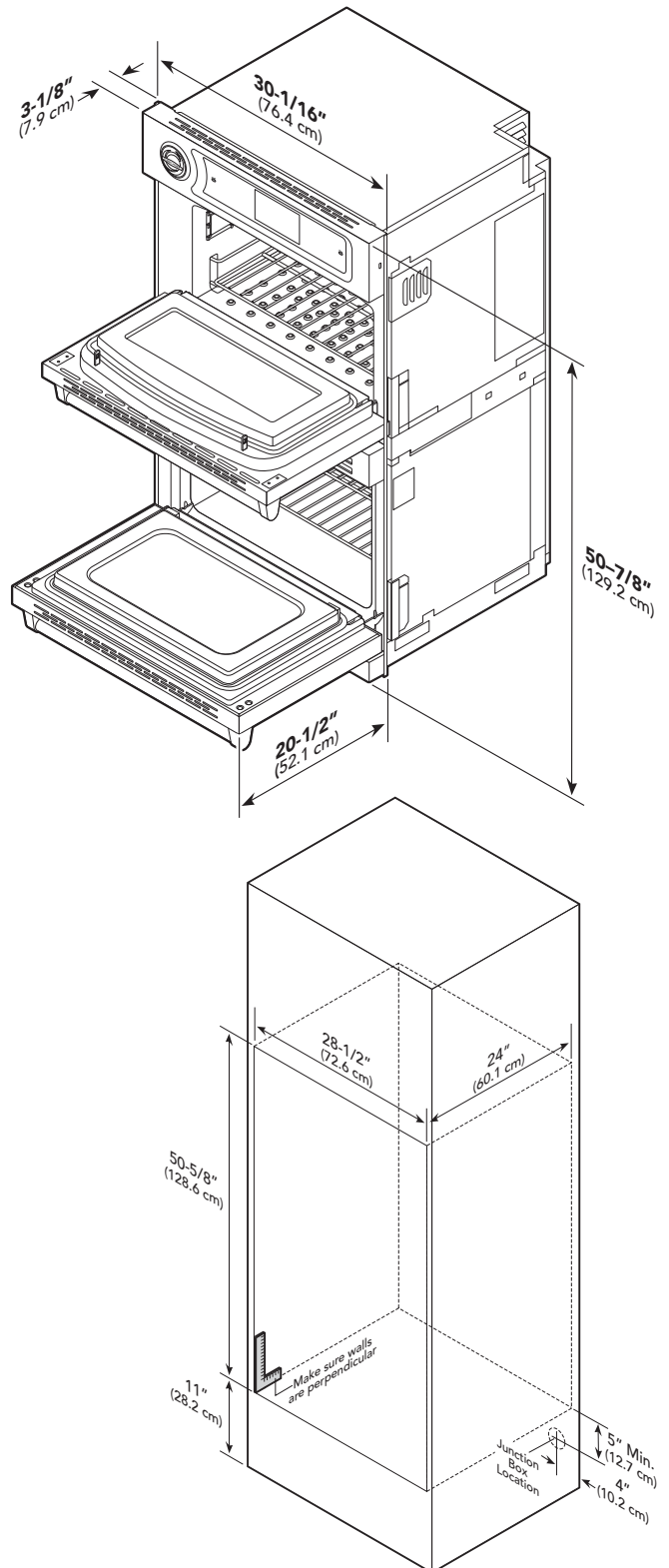

Please do not prepare installation from brochure data only. See installation instructions for important clearance/installation information.

*For 208V applications – please order model LVDOT730





The finest kitchen in the world doesn't amount to much unless it's filled with your family and friends. Viking Range, LLC applies this same philosophy to our offices and factory floors. Even though our products ship around the world, the company has always stayed true to its roots in Greenwood, Mississippi. The Viking range was born here, and our decision to set up shop (and more importantly, keep shop) in our hometown is a testament to the value of our roots and the commitment we have to building Viking products in the USA.

At Viking, people are our greatest asset. We are so proud of our employees and the products they build here in the heart of the Mississippi Delta that we confidently offer the industry's best and most comprehensive warranty, the Viking 3-Year Signature Warranty, on our Viking and Viking Professional products, and Ninety-Day No Quibble Guarantee*.

*Viking will repair or replace your product – no questions asked – in the unlikely event you have a service call within the first 90 days of purchase due to a manufacturing defect.



Viking Range, LLC 111 Front Street Greenwood, Mississippi 38930 USA For product information, call 1-888-845-4641 or visit vikingrange.com.

© 2015 VIKING RANGE, LLC. ALL RIGHTS RESERVED.