

1215WC • 15" Wine Captain® Model • 1000 Series

FEATURES & BENEFITS



STAINLESS FRAME



INTEGRATED FRAME



BLACK FRAME

PERFORMANCE	<ul style="list-style-type: none"> • Volume of 2.9 cu ft holds up to 24 wine bottles (750 ml) • Digital Touch Pad Control is conveniently located on upper face of unit • Temperature range: 38°F - 65°F • Digital passive cooling system • Maintains temperature to within 1°F of the set point to maximize preservation • Relative humidity inside the unit is approx. 50% • Rubber mounted compressor virtually eliminates vibration
INTERIOR/EXTERIOR	<ul style="list-style-type: none"> • Black interior is illuminated with LED lighting that automatically turns off when the door is closed, or can be set to stay on for 3 hours • Three-quarter extension black vinyl wine racks with natural beech wood fronts allow for easy access and prevent bottles from shifting • Wine racks accommodate a variety of bottle shapes and sizes, while the fourth and fifth racks allow for larger diameter wine and champagne bottles • LowE coated, argon gas filled thermopane glass door provides protection from harmful UV light • Standard commercial stainless steel handle is interchangeable with professional handle accessory • Door swing is field reversible
INTEGRATION	<ul style="list-style-type: none"> • Unit is designed to be built-in or can be freestanding • Solid natural beech wood fronts on wine racks can easily be stained to match surrounding cabinetry • Integrated model requires 3/4" custom door panel • Four independently adjustable leveling legs provide a precise undercounter fit • Available in the following finishes: Stainless, Integrated, or Black

MODEL DETAILS

Model	Voltage	Door Swing	Finish	Shipping Weight
U-1215WCS-00A	115	Field Reversible	Stainless Frame	102 lbs
U-1215WCINT-00A	115	Field Reversible	Integrated Frame	99 lbs
U-1215WCB-00A	115	Field Reversible	Black Frame	102 lbs

ACCESSORIES

Model	Description	Finish	Shipping Weight
23074	Professional Door Handle, 1 1/4" Diameter	Stainless	2 lbs
23073	Commercial Door Handle, 7/8" Diameter	Stainless	2 lbs

1000 Series • 15" Wine Captain® Model • 1215WC
DIMENSIONS

Dimensions shown apply to all finishes, including Integrated (INT) models with 3/4" overlay panel/frame installed.

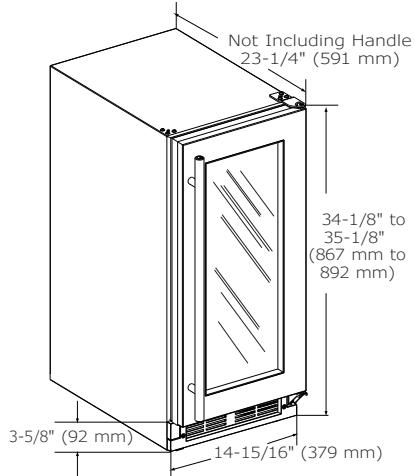
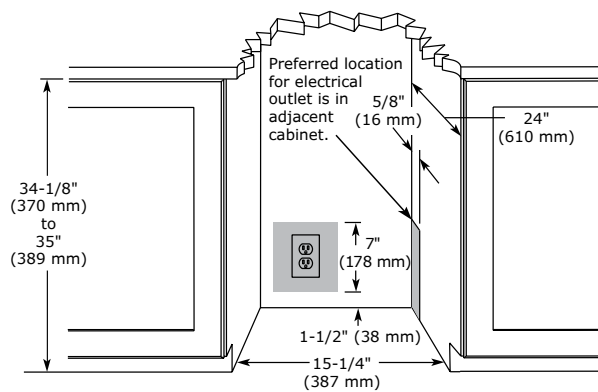
CABINET CUT-OUT

INSTALLATION NOTES

When installing adjacent to wall, ensure 2 1/2" clearance on hinged side for 90° door opening

Cutout includes the additional 1/4" width overall to ensure proper installation.

No additional clearance around sides, top or rear of unit is needed for ventilation.

Do not obstruct front grille air flow.

SPECIFICATIONS

Model	1215WC
Amps: Running	1.2
Capacity: Volume (cu ft)	2.9
Capacity: Wine Bottle (750 ml)	24
Control Type	Digital Touch Pad
Dimensions: Product Depth	23 1/4" / 591 mm
Dimensions: Product Height	34 1/8" / 867 mm
Dimensions: Product Width	14 15/16" / 379 mm
Energy Consumption: Avg. Per Year	250 kWh
ENERGY STAR	na
Product Weight: Max	95 lbs
Refrigerant Type	R600a
Sabbath (Star K Certified)	Yes
Temperature Range	38°F - 65°F

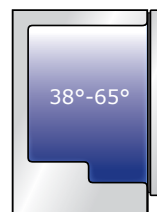
COOLING SYSTEM

ELECTRICAL REQUIREMENTS

This unit requires a grounded a polarized 115 VAC, 60 Hz, 15 A power supply (normal household current).



Residential & Commercial

Please visit u-line.com to view this model's User Guide. All specifications are subject to change without notice.