

# Tratto

an elegant arc

- wall canopy rangehood
- elegant styling
- 600 cfm PRO motor
- Silent Kit noise reduction
- 2 halogen lights
- 3 speed push button controls
- stainless steel baffle filters
- convertible to ductless\*
- Easy Cube mounting system
- some range: 3.5 - 6.5
- 6" round duct

DESIGNER



*Glass and stainless combine for an elegant arc.*

\* it is highly recommended that professional style cooking always be vented to the outside.



Size/Color/Model #

36 Stainless 630003948



pro-style baffle filters with European flair and a built-in grease control system; bright halogen lights encircled by a stainless trim

- a **High Ceiling Chimney Kit**
- c One 40" upper chimney to replace 16 1/8" upper chimney that came with hood
- c Stainless 620000360
- e
- s **Ductless Conversion Kit**
- s Includes: • Lower Chimney with holes for ducting
- s • Ductless Diverter Assembly • Vent Grates
- o • Charcoal Filter
- r Stainless 620000361
- i
- e **Replacement Charcoal Filter** 620000041
- s

## Dimensional Diagrams

**Ducted**

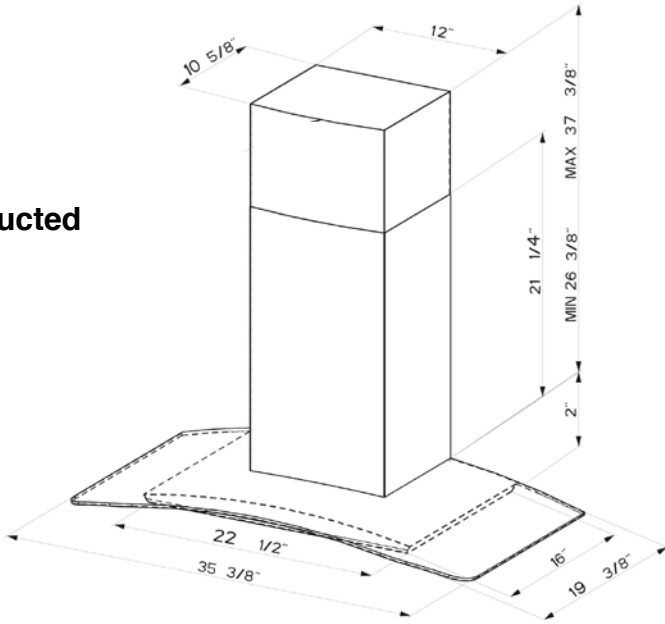

**Ductless**

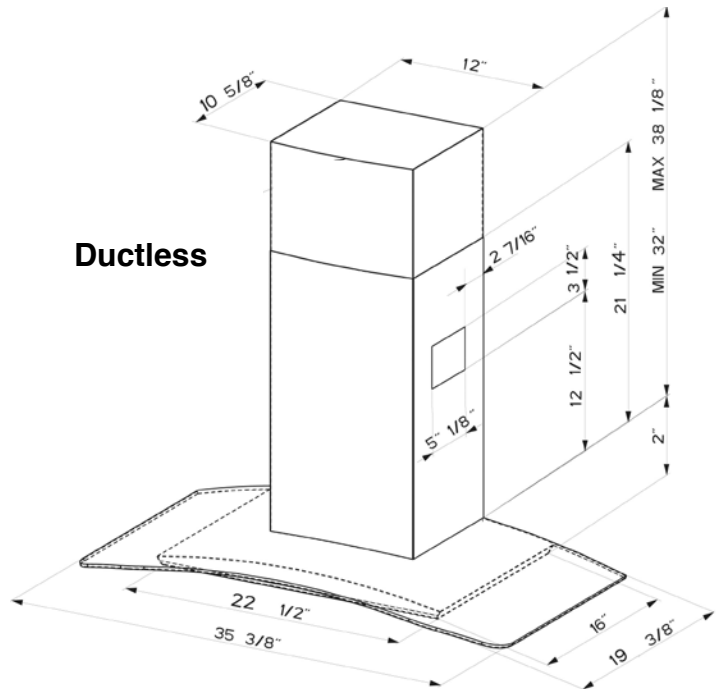

**Pre-Planning Your Installation - Important:** Consult the installation instructions before you begin installing this rangehood.

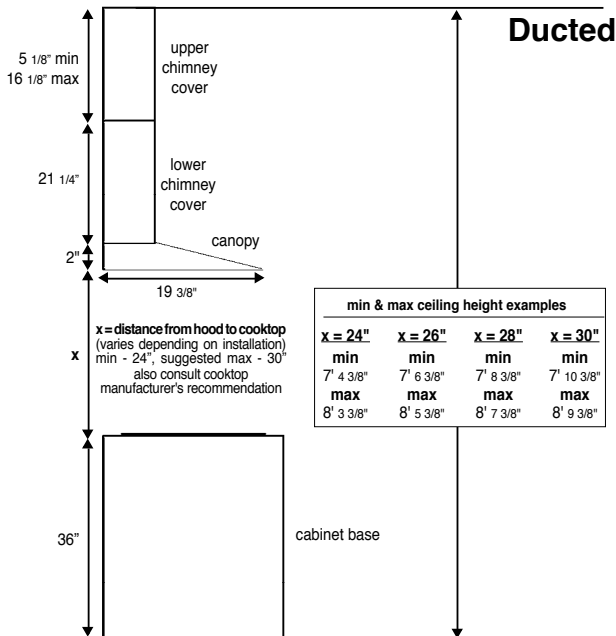

For ducted installations, the chimneys can be adjusted for ceilings between 7' 4 3/8" and 8' 9 3/8" depending on the distance between the bottom of the hood and the cooktop (**distance x in Ducted diagram**).

For ductless installations, the chimneys can be adjusted for ceilings between 7' 9 1/4" and 8' 9 3/8" depending on the distance between the bottom of the hood and the cooktop (**distance x in Ductless diagram**).

For shorter ceilings, have the chimney cover(s) cut at a sheet metal shop. For higher ceiling installations, the **High Ceiling Chimney Kit** includes a new 40" upper chimney which would replace the 16 1/8" upper chimney that came with the hood.

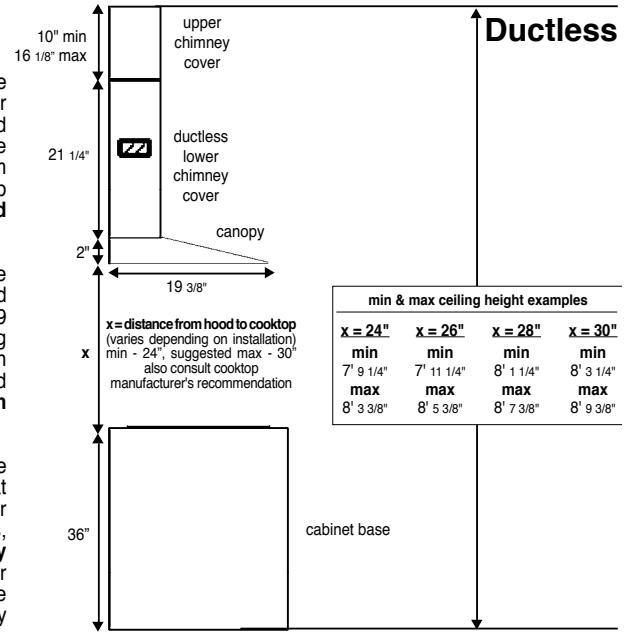

**Pre-Planning Your Installation - Important:** Consult the installation instructions before you begin installing this rangehood.

Make your ductrun as straight and short as possible. The ductrun should not exceed 35 equivalent feet if ducted with the required minimum of 6" round duct. Count 45° angles as 3 feet, 90° elbows as 5 feet, and 90° flat elbows as 12 feet.

For best results, use no more than three 90° elbows. Make sure that there is a **minimum of 24"** of straight duct between elbows if more than one is used. **Do not install two elbows together.** If you must elbow right away, do it as **far away** from the hood's exhaust opening as possible.

**WARNING!** Product specifications are subject to change without notification. Consult the installation instructions before you begin installing this rangehood.

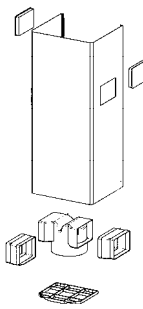

### Ductless Installations\*

For installations where ductwork is impossible or highly impractical, a **Ductless Conversion Kit** is available. A charcoal filter, which attaches under the blower assembly, absorbs smoke and odors. A ductless diverter assembly directs the air out to a lower chimney with vent grates cut into the sides.

\* it is highly recommended that professional style cooking always be vented to the outside.