

## Total Control Range Cooker



IT WILL FOREVER CHANGE THE WAY YOU COOK







# Simply a Better Way to Cook

As the next generation of European cooking technology, AGA Total Control is an unrivaled range cooker by function and revered status symbol by design—now engineered for ultimate cooking flexibility.

## Classic cast iron cooking meets innovative control technology

Unlike the traditional AGA cooker, the AGA Total Control features state-of-the-art touchscreen controls for multi-function flexibility and a digital remote to program the ovens to turn on and off at scheduled times. And for the first time, each oven and hotplate has its own heat source for even more efficiency and versatility.

What hasn't changed is the way the AGA cooks. 10 cast iron cooking functions helps produce what AGA is known for—beautiful food with better flavor, moisture and nutritional quality. Bake bread, roast meat, boil water, simmer soup, and warm tortillas all at the same time...only with the AGA Total Control, you merely turn on what you need!

AGA Total Control is fundamentally simple and the results amaze. It's what makes an owner a forever AGA advocate. And, your investment will pay you back many times over with wonderful meals shared with those you love and warm memories gathered 'round the AGA.

## CONTENTS

---

Why AGA Food Tastes Better	4
Quick Tour of the AGA Total Control	5
The 10 Cooking Methods	6
Programming to Suit Your Lifestyle	7
A Beloved Design Icon	8
Dream in Color: Your Options	9
Three-Oven Total Control	10
Five-Oven Total Control	11
The AGA Heritage	13
Specifications	14



## CAST IRON – IT'S WHY AGA FOOD TASTES BETTER



Ovens feature multi-function cooking - simply select the ideal position. For instance, grill on the top, bake in the middle and fry on the base.

Anyone who's ever tasted AGA food will emphasize it really does taste better, just one of the many reasons AGA Total Control holds an elevated status in homes worldwide. The secret is cast iron. The indirect radiant heat within the ovens comes from all surfaces consistently, without the drying, direct heat present in the elements or flames of other ranges. It's a gentle, even heat that locks in moisture, flavor, texture, and goodness—giving you the very best out of your ingredients.

### **Ingenious, multi-functional oven design**

People watching the AGA Total Control in action are usually shocked at its capacity. With oversized hotplates and ovens capable of holding a 28 lb. turkey, the AGA Total Control can cook an entire holiday meal, seamlessly and simultaneously. And, AGA cookware is designed with recessed lid handles so that saucepans can be stacked, making the AGA Total Control's interior space even more incredible.



## Ovens

### 1. Roasting Oven (465° F)

Grill, roast, and bake gourmet-quality food. This new technology makes it possible to use it with or without the other ovens on.

### 2. Baking oven (365° F)

A moderate temperature oven for baking cakes and biscuits, cooking fish, lasagna or a shepherd's pie, the AGA Total Control baking oven is truly flexible. And cooking sweet and savory dishes together is no problem as the flavors do not mix.

### 3. Simmering oven (212° F)

Allows flavors to develop and makes even the toughest meats tender, similar to a slow cooker only better.



## Hot Plates

Both the boiling plate (626° F) and simmering plate (392° F) are a generous 14 1/2" wide, easily accommodating extra-large pans and multiple saucepans. That means you can prepare up to 6 dishes at one time—something you cannot achieve on the 6" to 8" cooktop elements of conventional ranges.



Both simmering and boiling plates are 14 1/2" in diameter

## THE 10 COOKING METHODS



### Hot Plates

**Boil** - Water boils rapidly on an AGA, and the 14 ½" boiling plate can accommodate multiple pans.

**Grill** - Cook succulent steaks and chops on the boiling plate in the special cast-iron grill pan. Fierce heat sears the outside of the meat, sealing in flavor and juices while cooking the inside to perfection.

**Fry** - Create fried or sautéed chicken that's crispier on the outside and moist on the inside.

**Simmer** - The simmering plate's gentle heat is perfect for making sauces and soups.

**Stir Fry** - For Asian cooking and fast stir fry, use the AGA wok on the boiling plate.

**Toast** - Using the special wire toaster, make toast crunchy on the outside and fluffy in the middle. Toast sandwiches directly on the simmering plate.



### Ovens

**Roast** - AGA roasts are superb. Shrinkage is reduced because there are no flames or elements to dry out the meat.

**Steam** - In the slow cook oven, steam a sponge pudding to perfection. Steaming vegetables locks in their full flavor and nutrients.

**Bake** - Like a traditional baker's brick oven, the AGA roasting and baking ovens provide all-around, consistent heat to create feathery pastries, moist cakes, and perfectly baked breads.

**Slow Cook** - Gentle, persistent heat helps you create richer, juicier casseroles, stews, and slow roasting or braising cuts of meat.



As the name implies, you have total control over how you cook, with no need for large knobs or dials. The sleek touchscreen panel and remote control allows you to operate the ovens and hotplates in any combination you wish, and program the times they turn on and off.

## Touch-screen Control Panel

### Manual

Each zone (an oven or hotplate) can be operated individually in manual mode. Any zone selected will remain on until switched off.

### Slumber (ovens only)

All three ovens are active, pre-set at a simmering heat. Slumber setting is ideal for slow cooking and providing your kitchen with a gentle heat, creating that unmistakable ambient AGA warmth. When the ovens are in slumber mode, they take less time to reach full heat.

### Auto (ovens only)

Choosing auto function brings selected ovens up to full heat from OFF when a program is set. The ovens can be selected to operate once or twice each day, with the start and finish time of the 'cooking cycles' set by the user.

### Auto slumber (ovens only)

Choosing this setting automatically brings the ovens up to full heat from slumber mode.

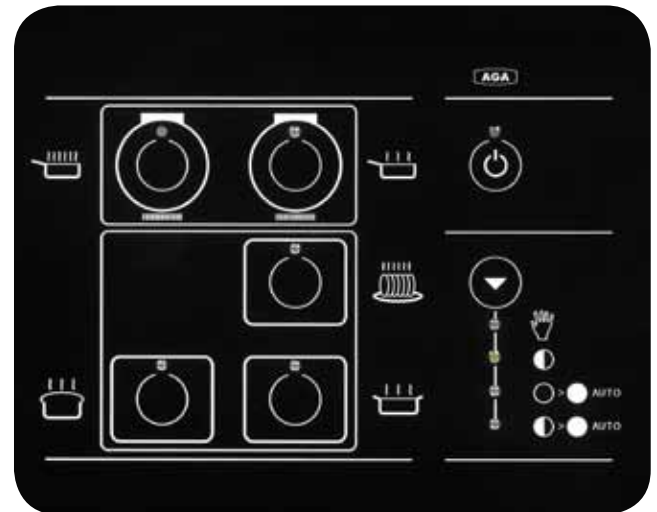

## Remote Control

Program the remote control handset to schedule the ovens to come on automatically for one or two cooking cycles per day, seven days per week. You can also set the AGA Total Control to fill your kitchen with the gentle ambient warmth for which the AGA cooker is renowned.



## A BELOVED DESIGN ICON

---

Deemed one of the top three design icons of the century by the BBC (next to the Coca-Cola bottle and Volkswagen Beetle), our look is undeniably timeless and turns heads. Instantly recognized by both professional and domestic chefs around the world and found in the homes of celebrities, your AGA Total Control is sure to be a stunning kitchen focal point.

### Here's just a taste of our lengthy list of famous AGA owners:

His Royal Highness Prince Charles	Shania Twain
Her Royal Highness Princess Anne	Colin Firth
Jamie Oliver	Elle MacPherson
Paul McCartney	Elizabeth Hurley
Kathryn Ireland	Claudia Schiffer
Sting	Jade Jagger
Madonna	Julie Walters
Kate Winslet	Sharon Stone





## DREAM IN COLOR: YOUR OPTIONS

The AGA Total Control is available in 12 stunning colors that complement contemporary or traditional kitchen settings.

Multiple protective coats of gleaming vitreous enamel give AGA range cookers a vivid hue, emblematic of its commanding status in the kitchen. Beyond its beauty, the finish is also hygienic and easy to clean.

### Signature colors



Black



Pearl Ashes



Pewter



Cream



Dark Blue



British Racing Green



Aubergine



White



Heather



Duck Egg Blue



Pistachio



Claret

Please note that while we take every care to ensure these colors are accurate, they are only as close as the printing process will allow. The unique enamelling process means that colors may darken when in use.

## THREE-OVEN AGA TOTAL CONTROL

### TC3

Three ovens and two hotplates are all operated from the touchscreen panel and remote control.

C – Control Panel		1 – Roasting Oven	(465° F)
B – Boiling Plate	(626° F)	2 – Baking Oven	(365° F)
S – Simmering Plate	(392° F)	3 – Simmering Oven	(212° F)

**“I have now, with the help of my collaborators, constructed a kitchen range which I think meets rather exacting demands on convenience and low running costs.”**

– Dr. Gustaf Dalén, Nobel Pulitzer Prize Winner, Swedish Physicist and Inventor of the AGA Cooker



TC5

Perfect for passionate cooks, large families or those with bigger kitchens, the 5-oven AGA Total Control combines the features of the three-oven model with even more cooking capacity, including a top warming plate, simmering oven and warming oven.

All operate as independent units—the additions provide the perfect heat to simmer casseroles, roasts, soups or stews, proof dough or keep food and dishes warm and ready to serve.

C – Control Panel		1 – Roasting Oven	(465° F)
W – Warming Plate	(100° F)	2 – Baking Oven	(365° F)
B – Boiling Plate	(626° F)	3 – Simmering Oven	(212° F)
S – Simmering Plate	(392° F)	4 – Slow Cook Oven	(248° F)
		5 – Warming Oven	(165° F)



# AGA

THE WORLD'S MOST FAMOUS COOKER AND WATER HEATER

FOR THE PRICE OF 6 CIGARETTES A DAY OR LESS

**YOUR AGA WILL...**

- 1 DO ALL YOUR COOKING
- 2 PROVIDE THREE HOT BATHS DAILY
- 3 GIVE YOU ALL YOUR WASHING-UP WATER

At your service day and night

Saves time, work and trouble

A life-time investment

And it's yours for £2 a month

## How to join the **AGAstocracy**

**Crowning glory—colour**  
Choose yours in cream, blue, grey, green, white, or in combinations of these colours with black as an extra top plate colour.

...and make life a bed of roses





THE ELECTRIC BLUE AGA



# The AGA Heritage

With a history stretching back 300 years, but technology absolutely right for modern living, the AGA is a range cooker that charms and stirs devoted affection.

The AGA has an extraordinary history. Each AGA range cooker is made at the historic Coalbrookdale foundry in England, a United Nations designated World Heritage Site. The Industrial Revolution began on this site in 1709 when Abraham Darby first used a new smelting process to manufacture cooking pots – just like the ones AGA still makes there today. For over 300 years our craftsmanship has been recognized throughout the world. Now part of AGA Rangemaster PLC, it is one of the few remaining cast iron foundries in the UK.

The AGA Cooker was invented by Nobel Prize winner Dr. Gustaf Dalen, a world renowned Swedish physicist. Confined to his home after a failed experiment cost him his sight, Dalen was inspired to create a better, simpler, more efficient cooker for his wife Elma, who constantly had to tend to their old-fashioned stove. Dalen was determined to develop a cooker capable of every culinary technique which was easy to use and that guaranteed perfect results. The now famous AGA was born.

In 1932 manufacturing also began in Britain. Today the AGA is solely made at the famous Coalbrookdale location in Shropshire, England.

The AGA is more than a range cooker; it's a way of life. Owners tell us their AGA adds heart and soul to their home. It's impossible to think of any other household appliance that inspires such a level of loyalty and devotion and has such emotional resonance with owners.

It is, without a doubt, simply a better way to cook.

**“During my career in advertising, I have sold scores of good products—all the way from IBM computers to Rolls Royce cars. The AGA cooker is the best of them all. I have been cooking on one ever since I graduated from the kitchens of the Hotel Majestic in Paris. I could not live without it.”**

– David Ogilvy, known as the King of Madison Avenue and the inspiration for the series Mad Men

## SPECIFICATIONS

### Three-Oven AGA Total Control



- C – Control panel

---

- B – Boiling plate

---

- S – Simmering plate

---

- 1 – Roasting oven

---

- 2 – Baking oven

---

- 3 – Simmering oven

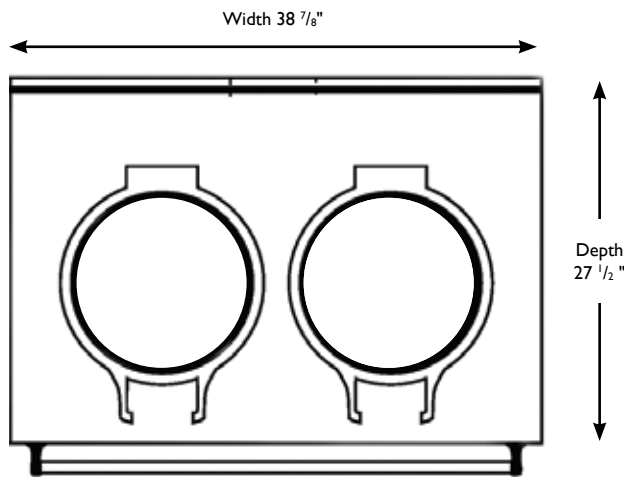

3 oven 30-amp electric AGA Total Control approximate range cooker weight 880 lbs (1,135 lbs shipping).

Oven doors are shipped unattached. Once doors are installed via simple hinge-pin system (no tools required), the unit is ready to plug in for use. 6-ft., 4-prong power cord attached.

The TC3 is a room vented appliance, fitted with a low level vent. AGA Range Vent Hoods are available through your AGA MARVEL Dealer.

	Height	Width	Depth (Shelf)
Oven dimensions	9 <sup>5</sup> / <sub>8</sub> "	13 <sup>5</sup> / <sub>8</sub> "	18 <sup>3</sup> / <sub>4</sub> "

\*For exact dimensions, please refer to installation instructions.

## SPECIFICATIONS

### Five-Oven AGA Total Control



- C – Control panel
- W – Warming plate
- B – Boiling plate
- S – Simmering plate
- 1 – Roasting oven
- 2 – Baking oven
- 3 – Simmering oven
- 4 – Slow Cook oven
- 5 – Warming oven

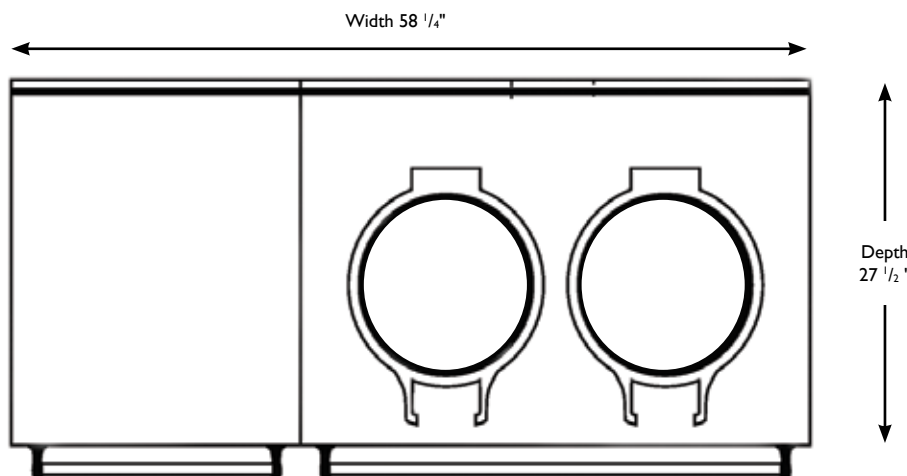

5 oven 30-amp electric AGA Total Control approximate range cooker weight 1,058 lbs (1,365 lbs shipping).

Oven doors are shipped unattached. Once doors are installed via simple hinge-pin system (no tools required), the unit is ready to plug in for use. 6-ft., 4-prong power cord attached.

The TC5 is a room vented appliance, fitted with a low level vent. AGA Range Vent Hoods are available through your AGA MARVEL Dealer.

	Height	Width	Depth (Shelf)
Roasting Oven	9 5/8 "	13 5/8 "	18 3/4 "
Baking Oven	9 5/8 "	13 5/8 "	18 3/4 "
Slow Cook Oven	9 5/8 "	13 5/8 "	20 1/4 "
Simmering Oven	9 5/8 "	13 5/8 "	18 3/4 "
Warming Oven	9 5/8 "	13 5/8 "	20 1/4 "

\*For exact dimensions, please refer to installation instructions.

# AGA MARVEL

## Premium Cooking and Food and Wine Preservation Brands

### AGA

Iconic ranges and cookers with unparalleled cooking precision, control, and styling

### MARVEL

Premium food and wine preservation

### La Cornue

The ultimate aspirational brand and world expert in domestic culinary art

### Heartland

Nostalgic beauty and craftsmanship combined with modern performance

### MARVEL Scientific

The quality leader in medical, scientific, and industrial refrigeration



### United States

AGA MARVEL  
1260 E Van Deine Street  
Greenville, MI 48838  
800-223-3900

### Canada

AGA MARVEL - SOFA Galleries  
6900 Airport Road, Suite 205  
Mississauga ON, L4V 1E8  
855-213-2785

### AGA MARVEL

[www.agamarvel.com](http://www.agamarvel.com)

© AGA MARVEL 2013, all rights reserved.  
Printed 4/13 41013223

The information presented herein is based on the best data available at time of printing and is believed to be correct. However, nothing stated herein is to be taken as warranty, expressed or implied, regarding the accuracy of the information or the use of our product or products. Products might not appear exactly as shown in images. Specifications and product esthetics are subject to change without notice.