

UC-24R



## FEATURES

Compact unit fits in anywhere

ENERGY STAR qualified

Temperature range from 34°F to 45°F

Easy-access touch control panel

Bright interior lighting

Clear utility bin for smaller items

Two-liter bottle storage in door

Spill-proof glass shelves for easy clean-ups

Rigorously tested in our U.S. manufacturing facilities to ensure decades of use

Exceptional 24/7 support from Madison, WI-based Customer Care team

## ACCESSORIES

Stainless steel pro handles

Stainless steel tubular handles

Stainless steel front panels with tubular or pro handles

Door lock

Dual installation kits

Silver or black dual wide kickplate

Accessories are available through an authorized Sub-Zero dealer. For local dealer information, visit [subzero-wolf.com/locator](http://subzero-wolf.com/locator).



## HANDLE ACCESSORIES

PRO



TUBULAR



## PRODUCT DETAILS

### REFRIGERATOR

- 2 Adjustable glass shelves
- 1 Stationary glass shelf
- 2 Door shelves
- Utility bin

**PRODUCT SPECIFICATIONS**

Model	UC-24R
Dimensions	23 7/8"W x 34"H x 24"D
Door Clearance	25 3/8"
Weight	130 lb
Refrigerator Capacity	5.7 cu ft
Electrical Supply	115 VAC, 60 Hz
Electrical Service	15 amp dedicated circuit
Receptacle	3-prong grounding-type

**ELECTRICAL**

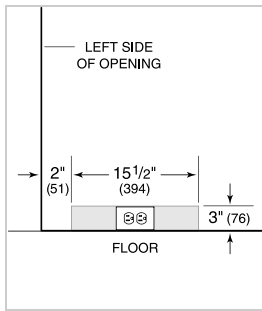

**INTERIOR VIEW**

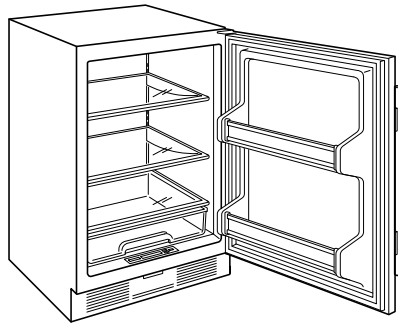

This illustration is intended for interior reference only and may not represent the exterior of the model being specified.

**DIMENSIONS**

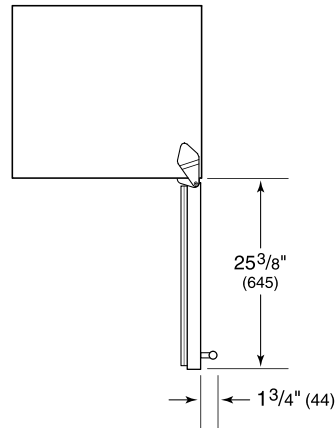
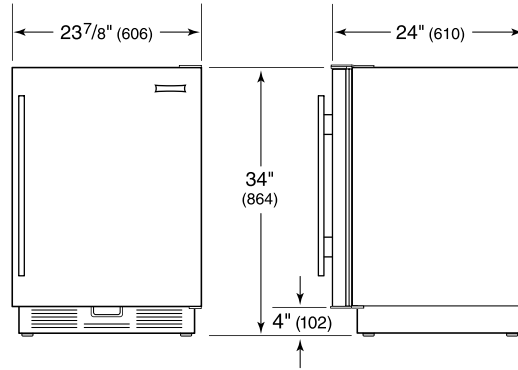

**STANDARD INSTALLATION**

