

NEW CONTROLS

Stilo Isola

Designer Collection

a tranquil island sculpture

- island canopy rangehood
- sleek styling
- 600 cfm PRO motor
- Silent Kit noise reduction
- 4 halogen lights with dimmer
- 4 Speed LED display control
- 30 minute auto off timer
- stainless steel baffle filters
- modified pro depth
- convertible to ductless*
- Easy Cube mounting system
- some range: 3.5 - 6.5
- 6" round duct
- Uses 25% less energy than previ-



 **FABER**

* it is highly recommended that professional style cooking always be vented to the outside.

With simple lines and minimal styling, the Stilo Isola exudes modern tranquility.



NKBA
National Kitchen & Bath Association

Size/Color/Model #

| | |
|-------------------|------------|
| 36 x 27 Stainless | STILIS36SS |
| 48 X 27 Stainless | STILIS48SS |

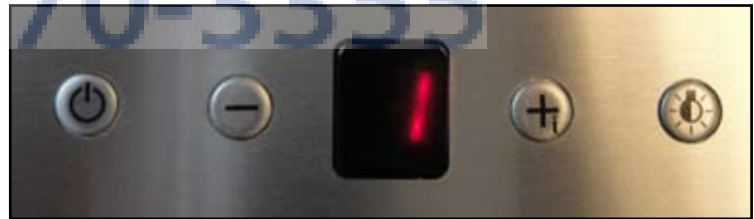

NOW WITH A NEW LED DISPLAY WITH ELECTRONIC TOUCH CONTROLS, 2 LEVEL LIGHTING, 30 MINUTE AUTO SHUT OFF, AND 10 MINUTE INTENSIVE SPEED CONTROL

a
c
c
e
s
s
o
r
i
e
s

High Ceiling Chimney Kit

Extends the island chimney for high ceilings

Stainless HIGH2

Ductless Conversion Kit

Includes: • Lower Chimney with holes for ducting • Ductless Diverter Assembly • Vent Grates • Charcoal Filter

Stainless DUCT2

Replacement Charcoal Filter

FILTER2

Dimensional Diagrams

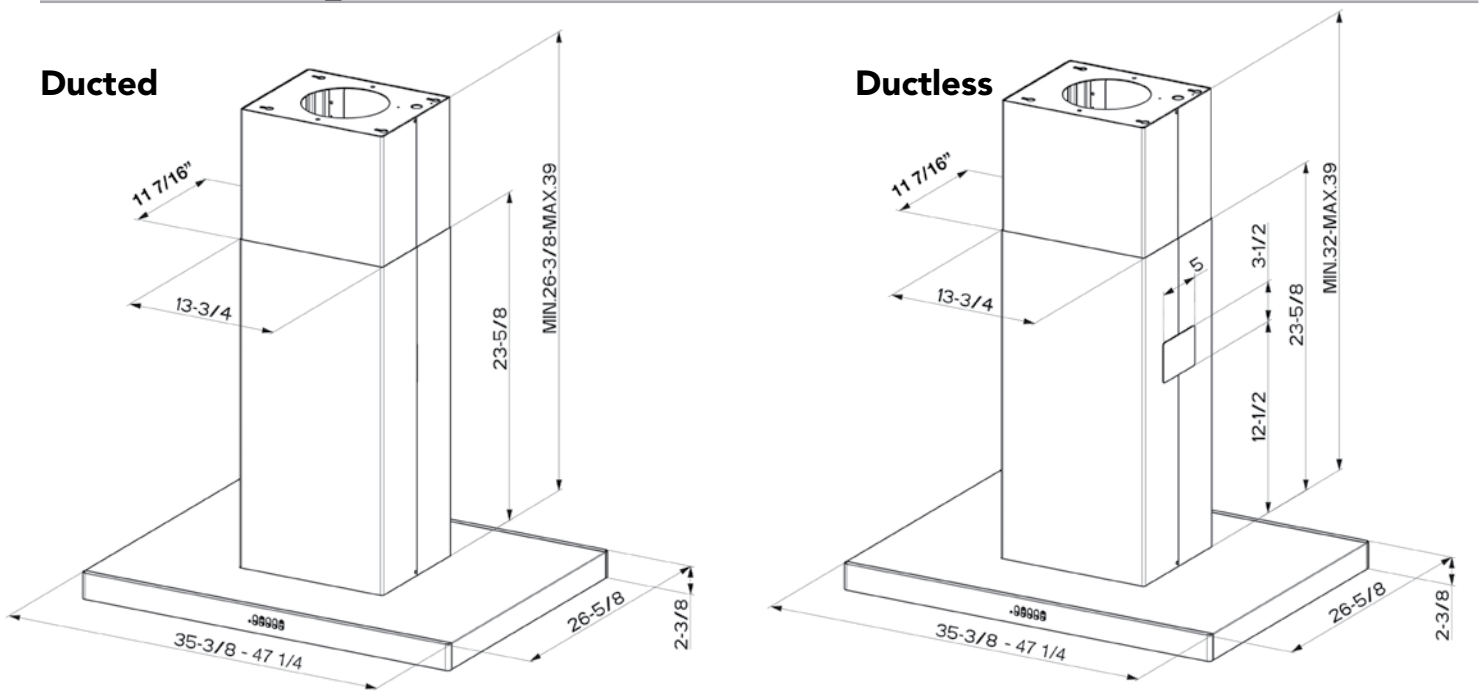

Pre-Planning Your Installation - Important: Consult the installation instructions before you begin installing this rangehood.

Ducted

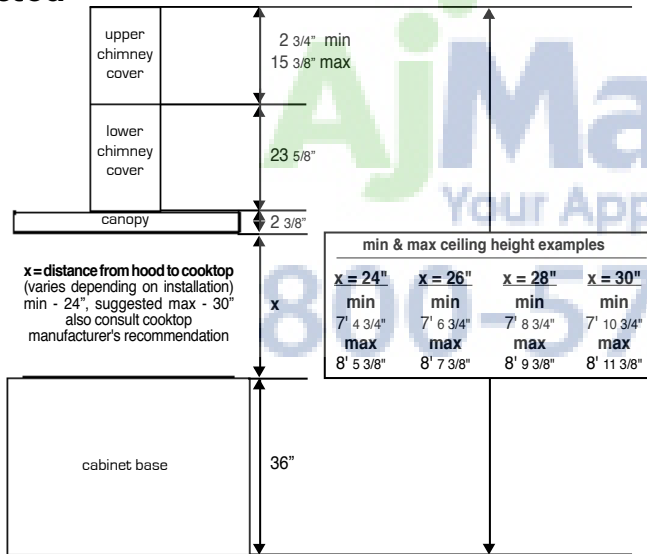

Ductless

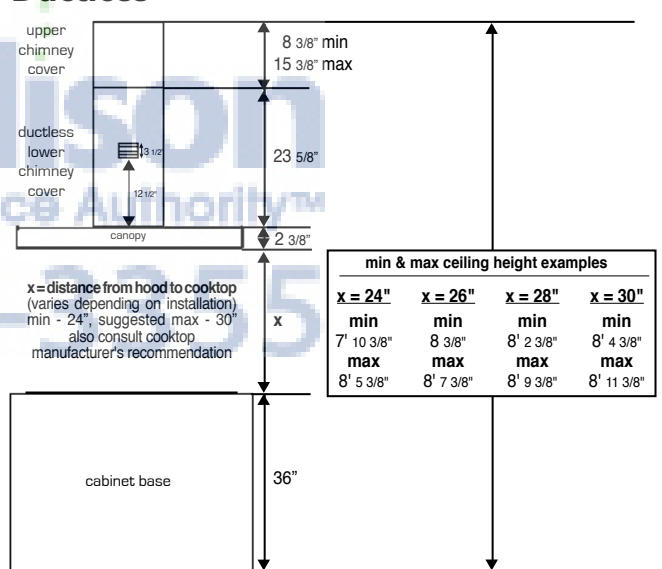

The ducted Stilo Isola chimney can be adjusted for ceilings between 7' 4 3/4" and 8' 11 3/8" depending on the distance between the bottom of the hood and the cooktop (distance x in above DUCTED diagram). The ductless Stilo Isola chimney can be adjusted for ceilings between 7' 10 3/8" and 8' 11 3/8" depending on the distance between the bottom of the hood and the cooktop (distance x in above DUCTLESS diagram). For higher ceiling installations, the High Ceiling Chimney Kit includes an additional support structure which adds 27 1/2" to the various ceiling heights in the figures above.

Pre-Planning Your Ductwork - Important: Consult the installation instructions before you begin installing this rangehood.

Make your ductrun as straight and short as possible. The ductrun should not exceed 35 equivalent feet if ducted with the required minimum of 6" round ductwork. Count 45° angles as 3 feet, 90° elbows as 5 feet, and 90° flat elbows as 12 feet.

For best results, use no more than three 90° elbows. Make sure that there is a minimum of 24" of straight duct between elbows if more than one is used. Do not install two elbows together. If you must elbow right away, do it as far away from the hood's exhaust opening as possible.

WARNING! Product specifications are subject to change without notification. Consult the installation instructions before you begin installing this rangehood. **Rev.07/11**

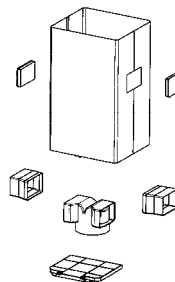

Ductless Installations

For installations where ductwork is impossible or highly impractical, a **Ductless Conversion Kit** is available. Charcoal filters, which attach to the blower assembly, absorb smoke and odors. A ductless diverter directs the air out to a lower chimney with vent grates cut into the sides. *** it is highly recommended that professional style cooking always be vented to the outside.**