



# SERVICE MANUAL

**18" & 24" ADA Models  
Built-In Dishwashers**



---

## FORWARD

This Service Manual, "18" & 24" ADA Built-In Dishwashers" (Part No. W11187658), provides the In-Home Service Professional with service information for the "18" & 24" ADA Built-In Dishwasher."

The Wiring Diagram used in this Service Manual is typical and should be used for training purposes only. Always use the Wiring Diagram supplied with the product tech sheet when servicing the dishwasher.

For specific operating and installation information on the model being serviced, refer to the "Use and Care Guide" or "Installation Instructions" provided with the dishwasher.

## GOALS AND OBJECTIVES

The goal of this Service Manual is to provide information that will enable the In-Home Service Professional to properly diagnose malfunctions and repair the "18" & 24" ADA Built-In Dishwasher."

The objectives of this Service Manual are to:

- Understand and follow proper safety precautions.
- Successfully troubleshoot and diagnose malfunctions.
- Successfully perform necessary repairs.
- Successfully return the dishwasher to its proper operational status.

WHIRLPOOL CORPORATION assumes no responsibility for any repairs made on our products by anyone other than authorized In-Home Service Professionals.

---

# TABLE OF CONTENTS

## 18" & 24" ADA Built-In Dishwashers

### SECTION 1 — GENERAL INFORMATION

DISHWASHER SAFETY .....	1-2
GENERAL INFORMATION .....	1-3
18" PRODUCT AND CABINET OPENING DIMENSIONS .....	1-4
24" PRODUCT AND CABINET OPENING DIMENSIONS .....	1-5
MODEL & SERIAL NUMBER LABEL .....	1-6
TECH SHEET LOCATION .....	1-6
MODEL & SERIAL NUMBER NOMENCLATURE .....	1-7
DISHWASHER SPECIFICATIONS .....	1-8

### SECTION 2 — DIAGNOSTICS & TROUBLESHOOTING

DIAGNOSTIC & TROUBLESHOOTING WARNINGS .....	2-2
SERVICE MODE - 24" DISHWASHER, FRONT DISPLAY .....	2-3
SERVICE MODE - 18" DISHWASHER, FRONT DISPLAY .....	2-4
SERVICE MODE - 18" & 24" DISHWASHER, TOP DISPLAY (PANEL READY) .....	2-5
SERVICE ERROR CODES .....	2-6
TROUBLESHOOTING GUIDE .....	2-7
CUSTOMER TROUBLESHOOTING GUIDE .....	2-11

### SECTION 3 — TESTING

TESTING WARNINGS .....	3-2
WIRING DIAGRAM .....	3-3
GENERAL THEORY OF OPERATION .....	3-4
POWER CHECK .....	3-4
DOOR SWITCH CIRCUIT .....	3-5
COMPONENT TESTING .....	3-6
CONTROL BOARD .....	3-6
WATER INLET VALVE .....	3-8
DISPENSER CIRCUIT .....	3-9
HEATING ELEMENT .....	3-10
TURBIDITY SENSOR .....	3-11
THERMISTOR .....	3-12
OVERFLOW SWITCH .....	3-13
FLOW METER .....	3-14
WASH PUMP .....	3-15
DRAIN PUMP .....	3-16
PRESSURE SWITCH .....	3-17
NOTES .....	3-18

*Continued on next page . . .*

---

# TABLE OF CONTENTS (CONTINUED)

## 18" & 24" ADA Built-In Dishwashers

### SECTION 4 — COMPONENT ACCESS

REMOVING THE TUB GASKET AND TRIM .....	4-2
REMOVING THE DOOR PANEL.....	4-3
REMOVING THE CONTROL PANEL (UI).....	4-4
REMOVING DOOR SWITCH ASSEMBLY .....	4-5
REMOVING DISPENSER ASSEMBLY .....	4-6
REPLACING THE INNER DOOR PANEL .....	4-7
REMOVING THE AIR BREAKER ASSEMBLY .....	4-8
REMOVING THE NOZZLE DUCT .....	4-9
REMOVING THE CONTROL BOARD .....	4-10
REMOVING THE WATER VALVE .....	4-11
UNDER TUB COMPONENTS.....	4-12
REMOVING THE PRESSURE SWITCH .....	4-13
REMOVING THE DRAIN PUMP .....	4-14
REMOVING THE THERMISTOR & TURBIDITY SENSOR.....	4-15
REMOVING THE HEATER ELEMENT .....	4-16
REMOVING THE WASH PUMP ASSEMBLY.....	4-17
REMOVING THE SUMP ASSEMBLY .....	4-18
NOTES .....	4-20

**PRODUCT SPECIFICATIONS & WARRANTY INFORMATION SOURCES** (inside back cover)

# Section 1: General Information

This section provides general safety, parts, and information for the 18" & 24" ADA Built-In Dishwashers.

- Dishwasher Safety
- General Information
- Dishwasher Care
- 18" Product and Cabinet Opening Dimensions
- 24" Product and Cabinet Opening Dimensions
- Model & Serial Number Label
- Tech Sheet Location
- Model & Serial Number Nomenclature
- Dishwasher Specification

## Dishwasher Safety

### Your safety and the safety of others are very important.

We have provided many important safety messages in this manual and on your appliance. Always read and obey all safety messages.



This is the safety alert symbol.

This symbol alerts you to potential hazards that can kill or hurt you and others.

All safety messages will follow the safety alert symbol and either the word "DANGER" or "WARNING."

These words mean:

**⚠ DANGER**

You can be killed or seriously injured if you don't immediately follow instructions.

**⚠ WARNING**

You can be killed or seriously injured if you don't follow instructions.

All safety messages will tell you what the potential hazard is, tell you how to reduce the chance of injury, and tell you what can happen if the instructions are not followed.

# General Information

## Filtration System and Maintenance

Your dishwasher has a filtration system that efficiently removes food particles from the wash water.

The filter system consists of three parts: a fine filter plate, a coarse filter, and a lower filter.

**IMPORTANT:** To avoid damage to dishwasher, do not operate your dishwasher without filters properly installed. Be sure lower filter is securely in place and upper filter assembly is locked into place. If the coarse filter turns freely, it is not locked into place.

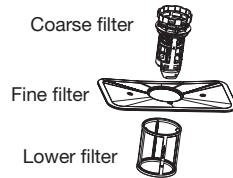

The filters may need to be cleaned when:

- Visible objects or soils are on fine filter plate.
- Dishes feel gritty to the touch.

See the “Filtration System” section in the full User Instructions for complete removal and maintenance schedule.

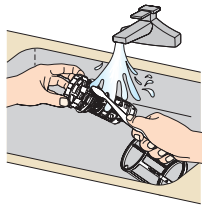

**IMPORTANT:** Do not use a wire brush or a scouring pad, etc., as they may damage the filters.

Rinse filter under running water until soils are removed. If you have hard-to-remove soils or calcium deposits because of hard water, a soft brush may be required.

## Drying – Rinse aid is essential

You must use a drying agent such as a rinse aid for good drying performance. Rinse aid along with the Heated Dry option will provide improved drying and avoid excessive moisture on the dishwasher interior.

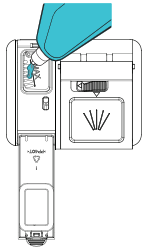

## Press START every time you add a dish

If anyone opens the door after the dishwasher has started (such as for adding a dish, even during the delay time), the Start button must be pressed again to resume the cycle.

Press START and push the door firmly closed.

START



## Adjust Upper Rack

You can raise or lower the upper rack to fit all items in either the upper or lower rack.

**To raise or lower the rack:**

Empty the rack. Pull the rack out halfway and take notice of the position of the carriage wheel assembly and side rail on each side of the rack. Lift up on the front of the rack while pulling the rack out all the way. The rack will then be completely free of the side rails. Reverse this action to re-engage the rack’s carriage wheels onto the rails in the higher or lower position desired.

**NOTE:** The upper rack must be level.

# Dishwasher Care

## Cleaning the Exterior

Clean the exterior of the dishwasher with only a soft, damp cloth and mild detergent. Avoid using abrasive cleaning products on the exterior of the dishwasher.

## Cleaning and Maintaining the Interior

Many detergents may leave white spots or a white residue on dishware and on the interior of the dishwasher. Over time this residue can become unsightly and could affect dishwasher performance. Use of a dishwasher cleaning product such as affresh® Dishwasher Cleaner can help to remove the residue. Monthly use of affresh® Dishwasher Cleaner is recommended to help maintain the dishwasher. Follow package directions.

**NOTE:** The manufacturer recommends the use of high-quality premeasured detergent tablets or packs and the use of rinse aid for dishwasher cleaning and daily care.

If you have a drain air gap, check and clean it if the dishwasher isn’t draining well.

## To Reduce Risk of Property Damage During Vacation or Extended Time Without Use:

- When you will not be using the dishwasher during the summer months, turn off the water and power supply to the dishwasher.
- Make sure the water supply lines are protected against freezing conditions. Ice formations in the supply lines can increase water pressure and cause damage to your dishwasher or home. Damage from freezing is not covered by the warranty.
- When storing your dishwasher in the winter, avoid water damage by having your dishwasher winterized by authorized service personnel.

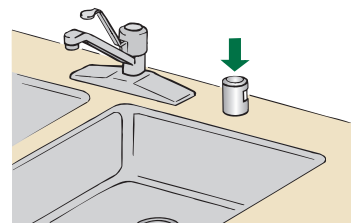

## 18" Product and Cabinet Opening Dimensions

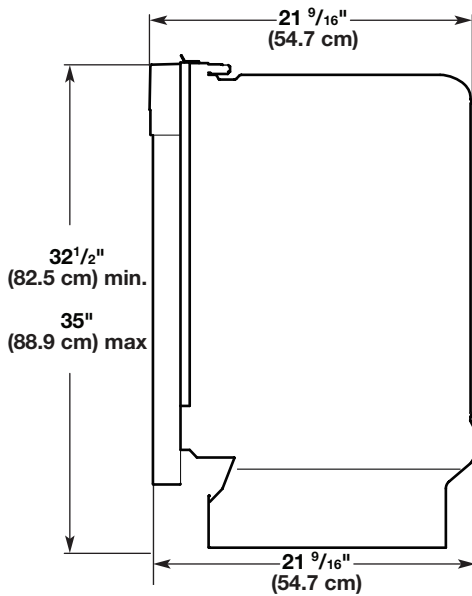

Side View 18" Custom Wood Panel

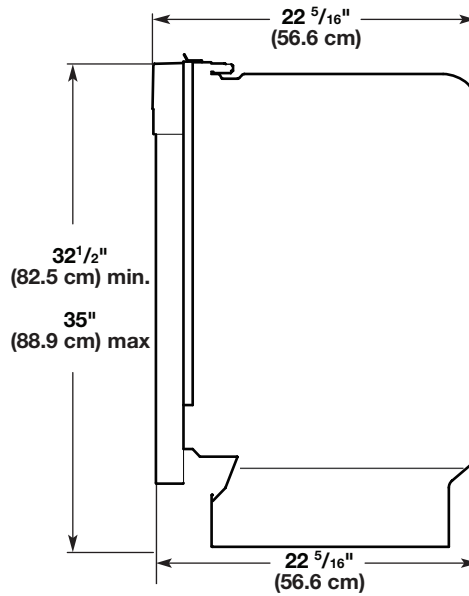

Side View 18" Metal Door Panel

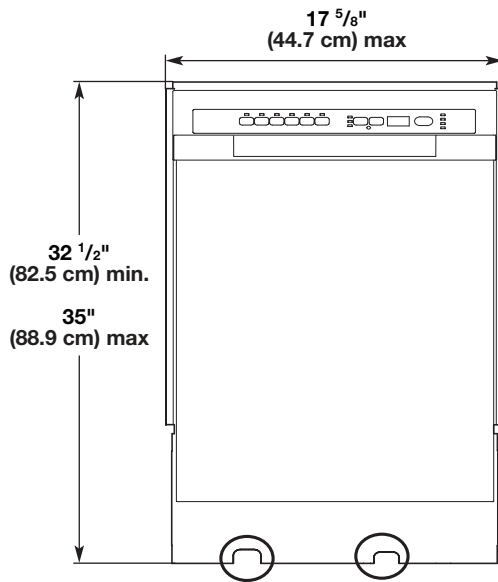

Front View

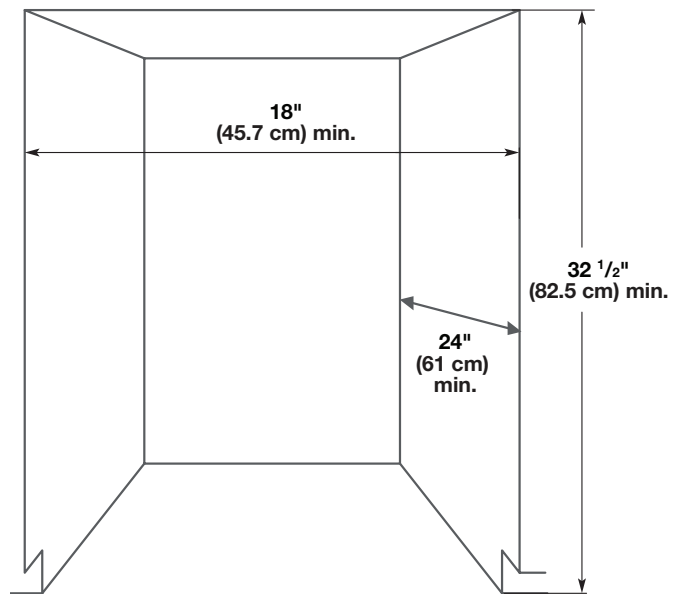

Cutout Dimensions

**NOTE:** Route the water supply line and power cable through the channels provided under the dishwasher (circled above).

### Underside of countertop to floor

The enclosure must be at least 18" wide, 24" (61 cm) deep, and 32½" (82.5 cm) high.

For the front door of the dishwasher to be flush with the leading edge of the counter top, the counter top must be at least 24" (61 cm) deep.

This dishwasher is designed to be enclosed on the top and on both sides by a standard residential kitchen cabinet unit. The installation enclosure must be clean and free of any obstructions.

**NOTE:** ADA installation, 32½" (82.5 cm) beneath 34" (86.4 cm) high countertops may be accomplished by adjusting the toekick and leveling legs.



## 24" Product and Cabinet Opening Dimensions

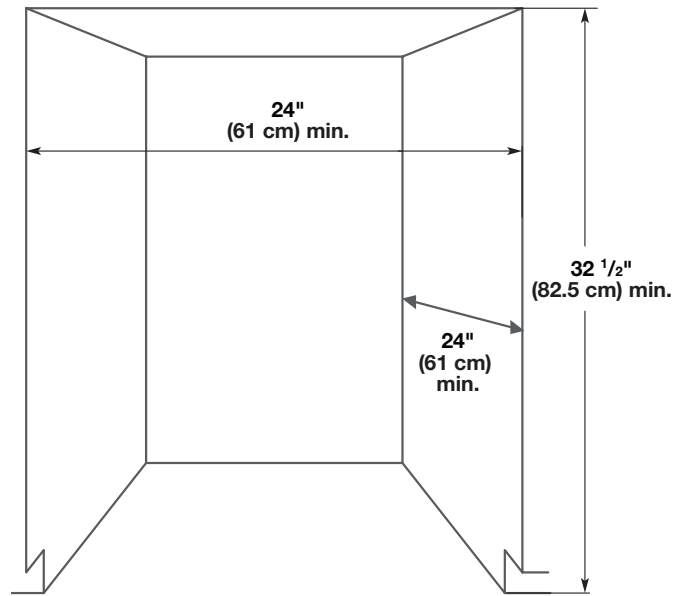
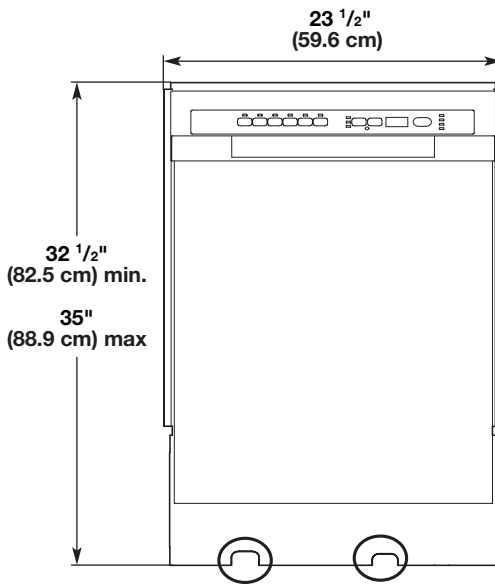
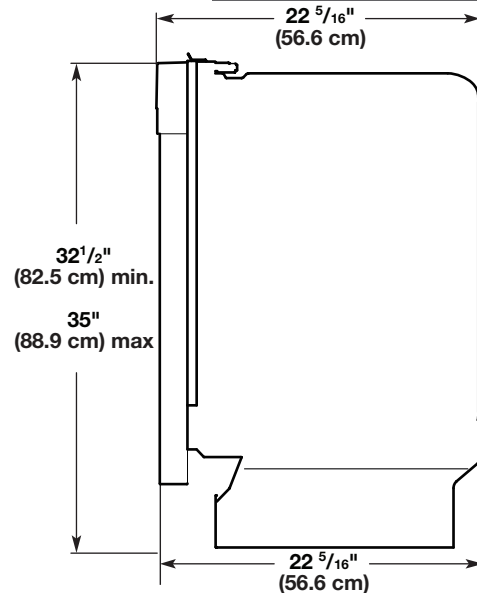
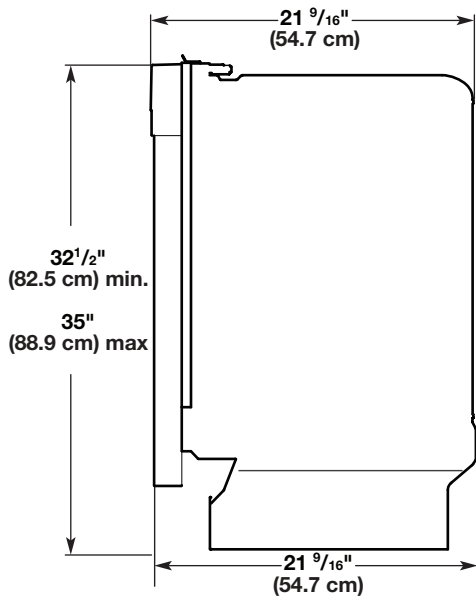

**NOTE:** Route the water supply line and power cable through the channels provided under the dishwasher (circled above).

### Underside of countertop to floor

The enclosure must be at least 24" (61 cm) wide, 24" (61 cm) deep, and 32½" (82.5 cm) high.

For the front door of the dishwasher to be flush with the leading edge of the counter top, the counter top must be at least 24" (61 cm) deep.

This dishwasher is designed to be enclosed on the top and on both sides by a standard residential kitchen cabinet unit.

The installation enclosure must be clean and free of any obstructions.

**NOTE:** ADA installation, 32½" (82.5 cm) beneath 34" (86.4 cm) high countertops may be accomplished by adjusting the toekick and leveling legs.

## Model & Serial Number Label

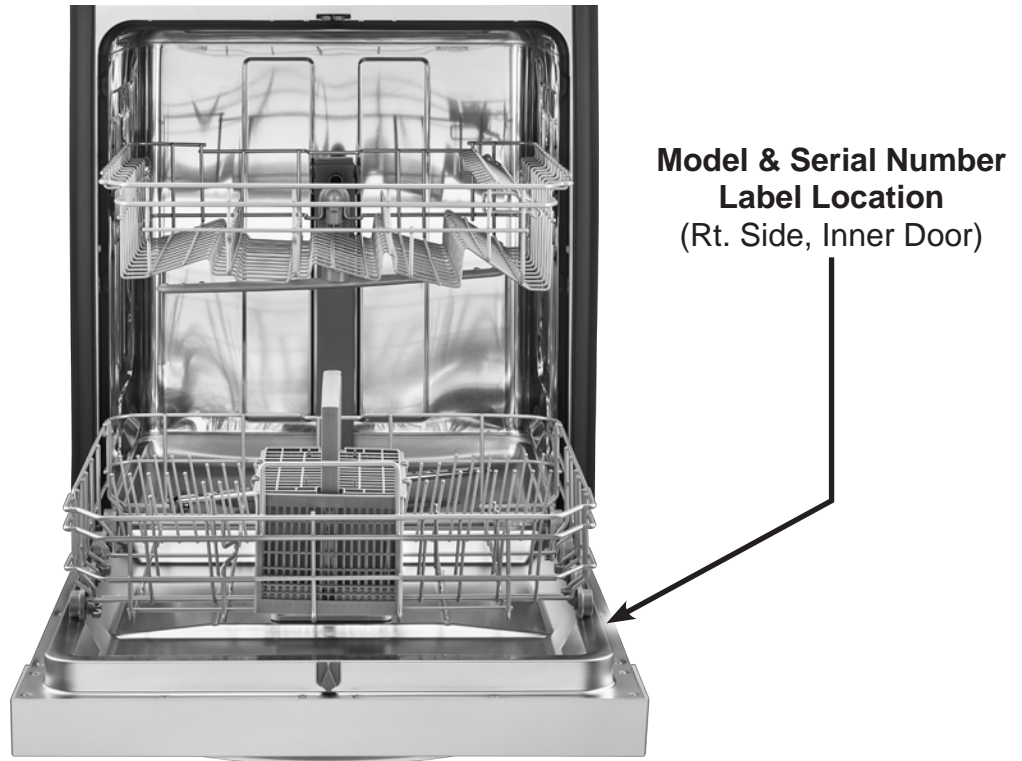

*Figure 7 - Model/Serial Number Label located inside, on left side wall, toward front.*

---

## Tech Sheet Location

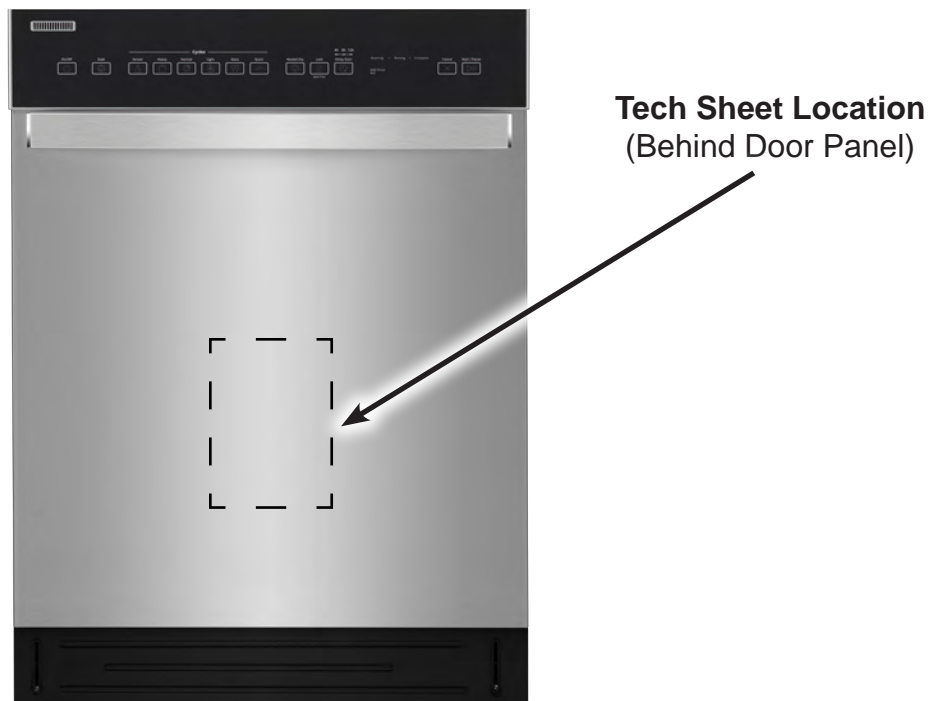

*Figure 8 - Tech Sheet located behind toe panel inside insulation folds.*

## Model & Serial Number Nomenclature

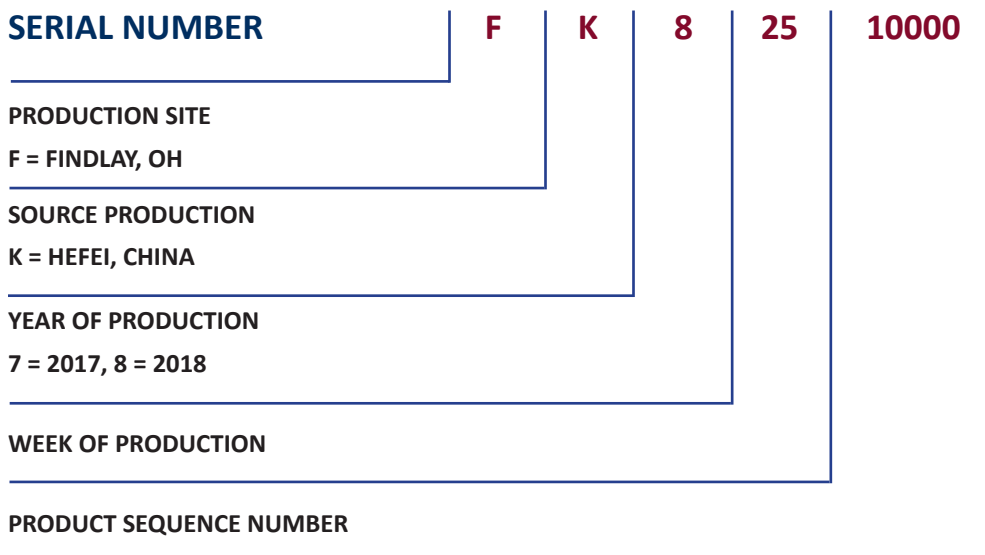
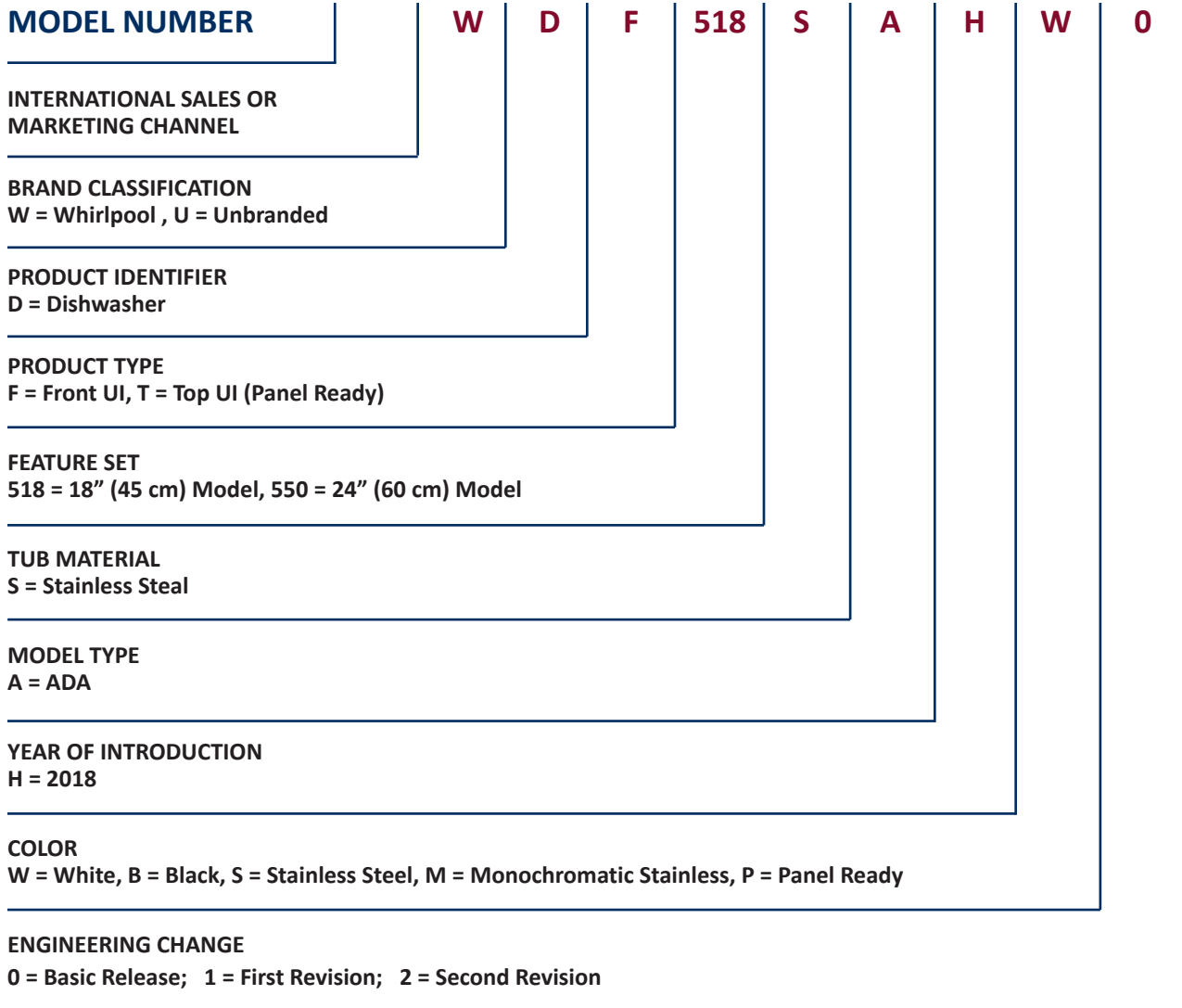

## GENERAL INFORMATION

# Dishwasher Specifications

Line Voltage/Frequency :	120 VAC / 60 Hz
Amps :	15 or 20 Amp
Circuit :	Separate circuit with time-delay fuse or circuit breaker
Supply Water Pressure :	20 - 100 psi
Supply Water Temperature :	120° F (49° C)
Water Charge	Approx. 3.8 L each fill
Dishwasher Type :	Built-in
Control Type:	Electronic Control/Tap Touch
Control Location :	Front (Top-Panel Ready)
Dispensers :	Detergent and Rinse Aid
Wash Levels :	4
Decibel Level :	50 dBA (18"), 51 dBA (24")
Cycles :	18" - (5) Heavy, Light/China, Normal, Quick Wash, Rinse Only 24" - (6) Glass, Heavy, Light/China, Normal, Quick Wash, Rinse Only
Drying System :	Recessed Heating Element
Tub Material :	Stainless Steel
Rack Material :	Nylon
Wash System :	Filter (Removable)
Racks :	2
Lower Spray Arm Rotation :	20 - 40 rpm
Upper Spray Arm Rotation :	15 - 40 rpm
ADA Compliant :	Yes
Energy Star Qualified :	Yes
Kosher Consumer Friendly :	Yes
CEE Tier :	Tier 1
<b>18" Dishwasher</b>	
Depth :	22" (55.88 cm) without handles, 22 7/16" (57 cm) with handles
Height :	34 1/2" (87.63 cm) max., 32 1/2 (82.55 cm) min.
Width :	17 5/8" (44.70 cm)
Weight :	75 lbs (34kg)
<b>24" Dishwasher</b>	
Depth :	24" (60.96 cm) without handles, 24 7/16" (62.10 cm) with handles
Height :	34 1/2" (87.63 cm) max., 32 1/2 (82.55 cm) min.
Width :	23 1/2" (59.69 cm)
Weight :	105 lbs (47.63kg)

## Section 2: Diagnostics & Troubleshooting

This section provides diagnostic, fault codes, and troubleshooting information for the 18" & 24" ADA Built-In Dishwashers.

- Diagnostics & Troubleshooting Safety
- Service Mode - 24" Dishwasher, Front Display
- Service Mode - 18" Dishwasher, Front Display
- Service Mode - 18" & 24" Dishwasher, Top Display
- Service Error Codes
- Troubleshooting Guide
- Customer Troubleshooting Guide

## For Service Technician Use Only

### **⚠ DANGER**



#### Electrical Shock Hazard

Only authorized technicians should perform diagnostic voltage measurements.

After performing voltage measurements, disconnect power before servicing.

Failure to follow these instructions can result in death or electrical shock.

### **⚠ WARNING**



#### Electrical Shock Hazard

Disconnect power before servicing.

Replace all parts and panels before operating.

Failure to do so can result in death or electrical shock.

### Voltage Measurement Safety Information

When performing live voltage measurements, you must do the following:

- Verify the controls are in the off position so that the appliance does not start when energized.
- Allow enough space to perform the voltage measurements without obstructions.
- Keep other people a safe distance away from the appliance to prevent potential injury.
- Always use the proper testing equipment.
- After voltage measurements, always disconnect power before servicing.

#### **IMPORTANT: Electrostatic Discharge (ESD) Sensitive Electronics**

ESD problems are present everywhere. Most people begin to feel an ESD discharge at approximately 3000V. It takes as little as 10V to destroy, damage, or weaken the main control assembly. The new main control assembly may appear to work well after repair is finished, but a malfunction may occur at a later date due to ESD stress.

- Use an anti-static wrist strap. Connect wrist strap to green ground connection point or unpainted metal in the appliance

-OR-

- Touch your finger repeatedly to a green ground connection point or unpainted metal in the appliance.
- Before removing the part from its package, touch the anti-static bag to a green ground connection point or unpainted metal in the appliance.
- Avoid touching electronic parts or terminal contacts; handle electronic control assembly by edges only.
- When repackaging main control assembly in anti-static bag, observe above instructions.

#### **IMPORTANT SAFETY NOTICE — “For Technicians only”**

This service data sheet is intended for use by persons having electrical, electronic, and mechanical experience and knowledge at a level generally considered acceptable in the appliance repair trade. Any attempt to repair a major appliance may result in personal injury and property damage. The manufacturer or seller cannot be responsible, nor assume any liability for injury or damage of any kind arising from the use of this data sheet.

## For Service Technician Use Only

### Service Mode

All ADA 18" & 24" dishwashers are programmed with a service mode to aid the technician in troubleshooting the dishwasher. Each component is cycled to verify if it is functioning correctly. Essentially, the procedure to enter service mode is similar between models except for a slight variation in button selection.

### To Enter Service Mode—24" Dishwasher, Front Display



Figure 1 - 24" Dishwasher, Front Display

1. Turn the dishwasher off and make sure no LED's are lit.
2. Disconnect power to the dishwasher.
3. Reapply power with the door open and quickly press and hold both the **On/Off** and **Start/Pause** buttons within 60 seconds from connecting power. Close the door and then the dishwasher will run as below.

### Service Mode Chart

NO.	COMPONENT	SSD*	NOTE
1	WATER VALVE	05 TURBIDITY VALUE	TURN ON WATER VALVE. THE FLOW METER WILL ALLOW 3 L OF WATER TO ENTER THE DISHWASHER. (THIS STEP WILL DISPLAY THE TURBIDITY VALUE ON THE SSD.)
2	WASH PUMP HEATER	04	TURN ON THE WASH PUMP. AFTER 10 SECONDS THE HEATER WILL TURN ON. THE BEEPER WILL SOUND WHEN THE TEMPERATURE HAS RISEN 3 - 5 DEGREES. THE DISHWASHER WILL STOP WHEN THE TEMPERATURE HAS REACHED 57°C. PRESS START TO ENTER THE NEXT STEP.
3	HIGH WASH PUMP DISPENSER	03	TURN ON THE WASH PUMP FOR 8 SECONDS AFTER 2 SECOND DELAY. THEN TURN ON THE DISPENSER FOR 45 SECONDS.
4	PAUSE	02	PAUSE FOR 30 SECONDS.
5	DRAIN PUMP	01	TURN ON THE DRAIN PUMP FOR 30 SECONDS.
6	END	BOARD TYPE CODE	BEEP ONE TIME. (THE SSD WILL SHOW THE BOARD TYPE CODE.)

\*SSD = Seven Segment Display

### To Exit Service Mode:

Disconnect power to the dishwasher.

## For Service Technician Use Only

### To Enter Service Mode—18” Dishwasher, Front Display



Figure 1 - 18” Dishwasher, Front Display

1. Turn the dishwasher off and make sure no LED's are lit.
2. Disconnect power to the dishwasher.
3. Reapply power with the door open and quickly press and hold both the **Cycles** and **Start/Cancel** buttons within 60 seconds from connecting power. Close the door and then the dishwasher will run as below.

### Service Mode Chart

NO.	COMPONENT	SSD*	NOTE
1	WATER VALVE	05 TURBIDITY VALUE	TURN ON WATER VALVE. THE FLOW METER WILL ALLOW 3 L OF WATER TO ENTER THE DISHWASHER. (THIS STEP WILL DISPLAY THE TURBIDITY VALUE ON THE SSD.)
2	WASH PUMP HEATER	04	TURN ON THE WASH PUMP. AFTER 10 SECONDS THE HEATER WILL TURN ON. THE BEEPER WILL SOUND WHEN THE TEMPERATURE HAS RISEN 3 - 5 DEGREES. THE DISHWASHER WILL STOP WHEN THE TEMPERATURE HAS REACHED 57°C. PRESS START TO ENTER THE NEXT STEP.
3	HIGH WASH PUMP DISPENSER	03	TURN ON THE WASH PUMP FOR 8 SECONDS AFTER 2 SECOND DELAY. THEN TURN ON THE DISPENSER FOR 45 SECONDS.
4	PAUSE	02	PAUSE FOR 30 SECONDS.
5	DRAIN PUMP	01	TURN ON THE DRAIN PUMP FOR 30 SECONDS.
6	END	BOARD TYPE CODE	BEEP ONE TIME. (THE SSD WILL SHOW THE BOARD TYPE CODE.)

\*SSD = Seven Segment Display

### To Exit Service Mode:

Disconnect power to the dishwasher.



## For Service Technician Use Only

### To Enter Service Mode—18" & 24" Dishwasher, Top Display (Panel Ready)



Figure 1 - 24" Dishwasher, Top Display



Figure 2 - 18" Dishwasher, Top Display

1. Turn the dishwasher off and make sure no LED's are lit.
2. Disconnect power to the dishwasher.
3. Reapply power with the door open and quickly press and hold both the **Rinse** and **Start** buttons within 60 seconds from connecting power. Close the door and then the dishwasher will run as below.

### Service Mode Chart

NO.	COMPONENT	SSD*	NOTE
1	WATER VALVE	05 TURBIDITY VALUE	TURN ON WATER VALVE. THE FLOW METER WILL ALLOW 3 L OF WATER TO ENTER THE DISHWASHER. (THIS STEP WILL DISPLAY THE TURBIDITY VALUE ON THE SSD.)
2	WASH PUMP HEATER	04	TURN ON THE WASH PUMP. AFTER 10 SECONDS THE HEATER WILL TURN ON. THE BEEPER WILL SOUND WHEN THE TEMPERATURE HAS RISEN 3 - 5 DEGREES. THE DISHWASHER WILL STOP WHEN THE TEMPERATURE HAS REACHED 57°C. PRESS START TO ENTER THE NEXT STEP.
3	HIGH WASH PUMP DISPENSER	03	TURN ON THE WASH PUMP FOR 8 SECONDS AFTER 2 SECOND DELAY. THEN TURN ON THE DISPENSER FOR 45 SECONDS.
4	PAUSE	02	PAUSE FOR 30 SECONDS.
5	DRAIN PUMP	01	TURN ON THE DRAIN PUMP FOR 30 SECONDS.
6	END	BOARD TYPE CODE	BEEP ONE TIME. (THE SSD WILL SHOW THE BOARD TYPE CODE.)

\*SSD = Seven Segment Display

### To Exit Service Mode:

Disconnect power to the dishwasher.

## For Service Technician Use Only

### Service Error Codes

**⚠ DANGER**



**Electrical Shock Hazard**

**Only authorized technicians should perform diagnostic voltage measurements.**

**After performing voltage measurements, disconnect power before servicing.**

**Failure to follow these instructions can result in death or electrical shock.**

### Failure Solutions:

1. If an alarm occurs, the machine will enter a failure solving process: The buzzer sounds once per second for 30 seconds. The error code will be displayed. During that time, the drain pump will turn on for 2 minutes.
2. During the drain, if the door is opened, the drain timing will pause.

ERROR CODE SSD*	ERROR CODE NON-SSD*	ERROR	CAUSES	WHAT TO CHECK
E1	“QUICK” INDICATOR FLASHES	WATER INLET FAILURE	DURING THE WATER INLET STEP, IF THE FLOW METER CAN’T DETECT A CORRECT FILL AFTER 4 MINUTES, <b>E1</b> WILL BE DISPLAYED.	<ol style="list-style-type: none"> <li>1. CHECK THE WATER SUPPLY.</li> <li>2. CHECK THE INLET VALVE.</li> <li>3. CHECK THE INLET.</li> <li>4. CHECK THE FLOW METER.</li> <li>5. CHECK THE PRESSURE SWITCH.</li> <li>6. CHECK THE DRAIN.</li> <li>7. CHECK THE CONTROL.</li> </ol>
E3	“QUICK” & “GLASS” INDICATORS FLASH	HEATER FAILURE	WHEN THE TEMPERATURE DOESN’T REACH THE CORRECT VALUE AFTER 90 MINUTES, <b>E3</b> WILL BE DISPLAYED.	<ol style="list-style-type: none"> <li>1. CHECK THE HEATER.</li> <li>2. CHECK THE THERMISTOR.</li> <li>3. CHECK THE CONTROL.</li> </ol>
E4	“LIGHT” INDICATOR FLASHES	OVERFLOW	IF WATER FLOWS INTO THE BASE AND ACTIVATES THE OVERFLOW SWITCH, THE DISHWASHER WILL DISPLAY <b>E4</b> .	<ol style="list-style-type: none"> <li>1. CHECK THE USE OF THE DETERGENT.</li> <li>2. CHECK WHETHER THE APPLIANCE IS LEVEL.</li> <li>3. CHECK THE OVERFLOW SWITCH.</li> <li>4. CHECK THE DRAIN PUMP.</li> <li>5. CHECK THE AMOUNT OF WATER IN SUMP.</li> <li>6. LOCATE LEAK AND REPAIR.</li> </ol>
E6	“LIGHT” & “GLASS” INDICATORS FLASH	NTC OPEN CIRCUIT FAILURE	TEMPERATURE SENSOR OPEN CIRCUIT, <b>E6</b> WILL BE DISPLAYED.	<ol style="list-style-type: none"> <li>1. CHECK THE INLET WATER TEMPERATURE.</li> <li>2. CHECK THE THERMISTOR.</li> <li>3. CHECK THE CONTROL.</li> </ol>
E7	“LIGHT, GLASS, & QUICK” INDICATORS FLASH	NTC SHORT CIRCUIT FAILURE	TEMPERATURE SENSOR SHORT CIRCUIT, <b>E7</b> WILL BE DISPLAYED.	<ol style="list-style-type: none"> <li>1. CHECK THE INLET WATER TEMPERATURE.</li> <li>2. CHECK THE THERMISTOR.</li> <li>3. CHECK THE CONTROL.</li> </ol>

\*SSD: Seven Segment Display (Not available on 24” Front Display Dishwashers.)

## For Service Technician Use Only

### Troubleshooting Guide

**⚠ DANGER**



**Electrical Shock Hazard**

**Only authorized technicians should perform diagnostic voltage measurements.**

**After performing voltage measurements, disconnect power before servicing.**

**Failure to follow these instructions can result in death or electrical shock.**

DESCRIPTION	POTENTIAL CAUSES	CHECK
<b>WON'T RUN OR POWER UP ("DEAD" KEYPAD/ CONSOLE)</b> > NO OPERATION > NO KEYPAD RESPONSE > NO LEDS OR DISPLAY	NO POWER TO UNIT OR BAD CONNECTION	CHECK FUSES, CIRCUIT BREAKERS AND JUNCTION BOX CONNECTIONS.
	LOOSE CONNECTIONS IN DISHWASHER POWER UP CIRCUIT OR BETWEEN KEYPAD(S) AND CONTROL	1. UNPLUG DISHWASHER OR DISCONNECT POWER. 2. CHECK RESISTANCE OF ALL CONNECTIONS IN POWER UP CIRCUIT TO CONTROL. CHECK CONNECTIONS BETWEEN KEYPAD(S) AND CONTROL.
	DOOR SWITCH NOT MAKING CONTACT: > FAULTY DOOR LATCH ASSEMBLY > FAULTY DOOR SWITCH	1. UNPLUG DISHWASHER OR DISCONNECT POWER. 2. MEASURE RESISTANCE OF DOOR SWITCH CONTACTS WHILE CHECKING MECHANICAL OPERATION OF LATCH ASSEMBLY. CONFIRM SWITCHES NOT LOOSE FROM ASSEMBLY.
	MULTIPLE OPEN OR SHORTED CIRCUITS IN KEYPAD	SEE "CHECKING KEYPAD OPERATION".
	FAULTY CONTROL	1. UNPLUG DISHWASHER OR DISCONNECT POWER. 2. CHECK/REPLACE CONTROL.
<b>WON'T RUN AND LED FOR START/RESUME KEY IS DEAD</b>	BY DESIGN, IF THE DOOR IS OPENED OR POWER IS INTERRUPTED DURING A CYCLE, THE USER MUST PRESS THE START/RESUME KEY TO RESUME OPERATION.	INSTRUCT CUSTOMER, REFER TO USE AND CARE GUIDE.
	THE DOOR MUST BE LATCHED FOR THE START/RESUME KEY TO WORK	CONFIRM DOOR IS CLOSED PROPERLY BEFORE PRESSING START/RESUME KEY. INSTRUCT CUSTOMER TO REFER TO USE AND CARE GUIDE.
	DOOR SWITCH NOT MAKING CONTACT: > FAULTY OR LOOSE DOOR LATCH ASSEMBLY (WHICH CAN BE AGGRAVATED BY HIGH DOOR CLOSURE FORCE) > FAULTY DOOR SWITCH (HIGH RESISTANCE) > FAULTY CONTROL DOES NOT DETECT DOOR CLOSED	1. UNPLUG DISHWASHER OR DISCONNECT POWER. 2. MEASURE RESISTANCE OF DOOR SWITCH CONTACTS WHILE CHECKING MECHANICAL OPERATION OF LATCH ASSEMBLY. CONFIRM SWITCHES NOT LOOSE FROM ASSEMBLY. CHECK STRIKE PLATE AND DOOR CLOSURE. 3. CHECK/REPLACE CONTROL.
	START/RESUME KEY NOT RESPONDING	SEE "ONE OR MORE KEYS WON'T RESPOND" PROBLEM BELOW.

**For Service Technician Use Only**

**Troubleshooting Guide (continued)**

DESCRIPTION	POTENTIAL CAUSES	CHECK
<b>CONTROL LOCK WON'T ACCEPT KEY PRESSES, CONTROL LOCK LED ON</b>	INTERMITTENT OPEN OR SHORT OF HEATED DRY KEY OR CIRCUIT IN KEYPAD OR KEYPAD CONNECTION	SEE "CHECKING KEYPAD OPERATION".
<b>ONE OR MORE KEYS WON'T RESPOND</b>	OPEN KEY OR LED CIRCUIT(S) ON THE KEYPAD, OR OPEN CIRCUITS ON THE CONTROL TO THE KEYS AND LEDS.	SEE "CHECKING KEYPAD OPERATION".
	DOOR SWITCH NOT MAKING CONTACT. ➤ FAULTY OR LOOSE DOOR LATCH ASSEMBLY (WHICH CAN BE AGGRAVATED BY HIGH DOOR CLOSURE FORCE) ➤ FAULTY DOOR SWITCH (HIGH RESISTANCE) ➤ FAULTY CONTROL DOES NOT DETECT DOOR CLOSED.	1. UNPLUG DISHWASHER OR DISCONNECT POWER. 2. MEASURE RESISTANCE OF DOOR SWITCH CONTACTS WHILE CHECKING MECHANICAL OPERATION OF LATCH ASSEMBLY. CONFIRM SWITCHES NOT LOOSE FROM ASSEMBLY. CHECK STRIKE PLATE AND DOOR CLOSURE. 3. CHECK/REPLACE CONTROL.
<b>WILL NOT FILL OR LOW WATER</b>	LOW WATER PRESSURE OR NO WATER TO DISHWASHER	VERIFY WATER IS TURNED ON AND SUPPLY LINE ADEQUATE. CORRECT INSTALLATION AS NECESSARY.
	LOOSE CONNECTION TO DISHWASHER FILL VALVE, OR IN THE VALVE CIRCUIT OR IN FILL VALVE SOLENOID	1. UNPLUG DISHWASHER OR DISCONNECT POWER. 2. CHECK RESISTANCES OF FILL VALVE SOLENOID AND ALL CONNECTIONS IN THE FILL CIRCUIT.
	DRAIN LOOP DETACHED FROM TUB AND/OR IMPROPER DRAIN CONNECTION	CHECK FOR WATER SIPHONING OUT OF THE UNIT: 1. ALLOW DISHWASHER TO COMPLETE A NORMAL FILL. 2. DRAIN FOR 5-10 SECONDS BY PRESSING CANCEL/ DRAIN. 3. OPEN DOOR AND CONFIRM WATER DOES NOT SIPHON OUT OF UNIT IF IT DOES, CONFIRM DRAIN LOOP IS ATTACHED TO SIDE OF DISHWASHER AND DRAIN HOSE IS CONNECTED TO A DRAIN AT LEAST 50.8 CM (20 INCHES) OFF THE FLOOR.
	INLET SCREEN ON FILL VALVE PLUGGED	DISCONNECT WATER LINE TO FILL VALVE AND INSPECT INLET FOR OBSTRUCTION.
	FAULTY FILL VALVE DRIVE CIRCUIT ON THE CONTROL	CHECK OPERATION OF FILL VALVE BY CONTROL DURING DIAGNOSTICS.
	CUSTOMER MISUNDERSTANDS PROPER WATER LEVEL	CUSTOMER INSTRUCT: NORMAL WATER LEVEL IS JUST ABOVE FILTER SCREEN.
<b>WASH PUMP WILL NOT PUMP</b>	PUMP MOTOR SEIZED UP (WILL NOT TURN)	1. UNPLUG DISHWASHER OR DISCONNECT POWER.
	PUMP MOTOR WINDINGS OPEN OR LOOSE/OPEN CONNECTION IN WASH PUMP CIRCUIT	1. UNPLUG DISHWASHER OR DISCONNECT POWER. 2. CHECK RESISTANCE OF PUMP MOTOR WINDINGS AND ALL CONNECTIONS IN THE WASH CIRCUIT INCLUDING THE PUMP MOTOR CAPACITOR.

**For Service Technician Use Only**

**Troubleshooting Guide (continued)**

DESCRIPTION	POTENTIAL CAUSES	CHECK
<b>WASH PUMP WILL NOT PUMP (CONTINUED)</b>	DOOR SWITCH NOT MAKING CONTACT CONSISTENTLY: ➤ FAULTY OR SLOPPY DOOR LATCH ASSEMBLY (WHICH CAN BE AGGRAVATED BY HIGH DOOR CLOSURE FORCE KEEPING STRIKE PLATE FROM FULLY SEATING) ➤ FAULTY DOOR SWITCH (HIGH RESISTANCE)	1. UNPLUG DISHWASHER OR DISCONNECT POWER. 2. MEASURE RESISTANCE OF DOOR SWITCH CONTACTS WHILE CHECKING MECHANICAL OPERATION OF LATCH ASSEMBLY. CONFIRM SWITCHES NOT LOOSE FROM ASSEMBLY. CHECK STRIKE PLATE AND DOOR CLOSURE.
	FAULTY MOTOR START CAPACITOR	1. UNPLUG DISHWASHER OR DISCONNECT POWER. 2. DISCONNECT CAPACITOR LEADS AND CONFIRM CAPACITANCE IS AS LABELED ON PART OR CHECK RESISTANCE FOR OPEN CIRCUIT ACROSS THE TERMINALS. REPLACE IF OPEN.
	EXCESSIVE SUDS IN PUMP DUE TO USING WRONG OR TOO MUCH DETERGENT OR RINSE AID	1. INSTRUCT CUSTOMER; REFER TO USE AND CARE MANUAL. 2. REPEATEDLY FILL AND CANCEL/DRAIN TO REMOVE SUDS. 3. CHECK DISPENSER IN DIAGNOSTICS AND RINSE AID SETTING.
	FAULTY WASH PUMP DRIVE CIRCUIT ON THE CONTROL	CHECK OPERATION OF WASH PUMP MOTOR DURING DIAGNOSTICS.
<b>WILL NOT DRAIN OR EXCESS WATER LEFT IN UNIT</b>	OBSTRUCTED DRAIN HOSE OR PATH	1. UNPLUG DISHWASHER OR DISCONNECT POWER. 2. CHECK FOR BLOCKAGES FROM SUMP CHECK VALVE TO CUSTOMER'S PLUMBING POTENTIAL ITEMS: • PLUGGED GARBAGE DISPOSER OR PLUG NOT KNOCKED OUT • BLOCKED/STUCK SUMP OR DRAIN LOOP CHECK VALVE • PLUGGED HOSES
	OPEN WINDING ON DRAIN PUMP MOTOR OR LOOSE/OPEN CONNECTION IN DRAIN MOTOR CIRCUIT.	1. UNPLUG DISHWASHER OR DISCONNECT POWER. 2. CHECK THE RESISTANCES OF DRAIN MOTOR WINDINGS AND ALL CONNECTIONS IN DRAIN CIRCUIT.
	DRAIN PUMP IMPELLER FRACTURED	1. UNPLUG DISHWASHER OR DISCONNECT POWER. 2. REMOVE DRAIN PUMP AND CHECK IMPELLER BY PULLING AND ROTATING. IF THE IMPELLER PULLS OFF EASILY OR TURNS FREELY (NORMALLY THERE IS SOME UNEVEN RESISTANCE). IF STRIPPED - REPLACE.
	DIAMETER OF DRAIN HOSE TOO SMALL	CHECK/INSTALL PROPER DRAIN HOSE.
	DRAIN LOOP CHECK VALVE NOT SEALING AND CUSTOMER DISPOSER/WASTE LINE PARTIALLY OR FULLY PLUGGED.	1. DISCONNECT DRAIN HOSE AT PLUMBING CONNECTION. 2. ELEVATE HOSE ABOVE DISHWASHER AND FILL WITH WATER IF WATER FLOWS INTO DISHWASHER, REPLACE ENTIRE DRAIN LOOP (INSTALL AS HIGH AS POSSIBLE AND ATTACH TO UNDERSIDE OF COUNTER TOP IF POSSIBLE).
	FAULTY DRAIN MOTOR DRIVE CIRCUIT ON CONTROL	CHECK OPERATION OF DRAIN MOTOR DURING DIAGNOSTICS.

**For Service Technician Use Only**

**Troubleshooting Guide (continued)**

DESCRIPTION	POTENTIAL CAUSES	CHECK
<b>DETERGENT NOT DISPENSING</b>	ITEM IN LOWER RACK BLOCKED LID OR BLOCKED SPRAY OF WATER TO DISPENSER	INSTRUCT CUSTOMER ON PROPER DISH LOADING.
	MECHANICAL BINDING OF DISPENSER LID	1. UNPLUG DISHWASHER OR DISCONNECT POWER. 2. CHECK/REPLACE DISPENSER.
	LID LATCH BINDING DUE TO EXCESS DETERGENT IN MECHANISM	INSTRUCT CUSTOMER ON PROPER DISPENSER FILLING.
	OPEN COIL ON DISPENSER SOLENOID OR LOOSE/OPEN CONNECTION IN DISPENSER CIRCUIT	1. UNPLUG DISHWASHER OR DISCONNECT POWER. 2. CHECK RESISTANCE OF DISPENSER COIL AND ALL CONNECTIONS IN DISPENSER CIRCUIT.
	FAULTY DISPENSER DRIVE CIRCUIT ON CONTROL	CHECK OPERATION OF DISPENSER DURING DIAGNOSTICS.
<b>POOR WASH</b>	<i>PLUGGED OR DAMAGED SCREENS</i>	<i>INSPECT FOLLOWING 3 SCREENS: REMOVE LOWER SPRAY ARM ASSEMBLY AND INSPECT FOREIGN OBJECT AND CHOPPER ASSEMBLY SCREENS. CLEAN/REPLACE AS NEEDED.</i>
	<i>SPRAY ARMS NOT ROTATING</i>	<i>CHECK FOR FREE AND PROPER ARM ROTATION BY OPERATING DISHWASHER AND OPENING DOOR TO SEE WHETHER ARMS REMAIN IN THE SAME POSITION IF ARMS BLOCKED BY DISH ITEM. INSTRUCT CUSTOMER MAY ALSO HAVE RESTRICTED MOVEMENT DUE TO MISALIGNMENT OF THE UPPER SPRAY ARM WATER DELIVERY SYSTEM.</i>
	<i>LOW INLET WATER TEMPERATURE OR HOOKED UP TO THE COLD WATER LINE</i>	<i>CONFIRM TEMPERATURE AT SINK (RECOMMEND 49° C/120F). INSTRUCT CUSTOMER TO RUN WATER AT SINK BEFORE RUNNING DISHWASHER.</i>
	<i>MECHANICAL ITEMS COVERED PREVIOUSLY</i>	<i>SEE “WASH PUMP WILL NOT PUMP” OR “WILL NOT DRAIN OR ACCESS WATER LEFT IN UNIT” OR “DETERGENT NOT DISPENSING” OR DETAILS ON TEMPERATURE SENSING IN “LONG CYCLE AND/OR STUCK IN CERTAIN PART OF CYCLE”.</i>
<b>FILM ON GLASSES AND/OR DISHES</b>	HARD WATER LEAVING FILM ON DISHES	CHECK WATER HARNESS. IF HARD, INSTRUCT CUSTOMER TO USE MAXIMUM DETERGENT OR TRY POURING 1/4 CUP OF GLASS MAGIC INTO BOTTOM OF DISHWASHER. ALSO RECOMMEND THE HIGH TEMP OPTION TO CLEAN THE DISHWASHER, RECOMMEND RUNNING WITH 1 CUP OF WHITE VINEGAR SITTING UPRIGHT IN UPPER RACK.
	DRAIN LOOP CHECK VALVE NOT SEALING	DISCONNECT DRAIN HOSE AT PLUMBING CONNECTION. ELEVATE HOSE ABOVE DISHWASHER AND FILL WITH WATER. IF WATER FLOWS INTO DISHWASHER, REPLACE ENTIRE DRAIN LOOP (INSTALL AS HIGH AS POSSIBLE AND ATTACH TO UNDERSIDE OF COUNTER TOP IF POSSIBLE).
<b>POOR DRY</b>	CUSTOMER NOT USING RINSE AID AND/OR HEATED DRY	RECOMMEND USE OF RINSE AID AND HEATED DRY. INSTRUCT CUSTOMER HOW TO FILL AND MONITOR RINSE AID.
	RINSE AID DISPENSER NOT DISPENSING	SEE LAST THREE ITEMS UNDER “DETERGENT NOT DISPENSING”.
	A HEATING PROBLEM COULD CAUSE POOR DRYING BUT WILL TYPICALLY CAUSE A WATER HEATING FAULT.	SEE “STOPPED RUNNING, WILL NOT START CLEAN LED BLINDS 7 TIMES, THEN REPEATS (WATER HEATING FAULT).



## For Service Technician Use Only

### Customer Troubleshooting Guide (From Use & Care Guide)

CUSTOMER COMPLAINT	RECOMMENDED SOLUTIONS
<b>DISHWASHER DOES NOT RUN OR STOPS DURING A CYCLE</b>	<p>IT IS NORMAL FOR CERTAIN CYCLES TO REPEATEDLY PAUSE FOR SEVERAL SECONDS DURING THE MAIN WASH. IS THE DOOR CLOSED TIGHTLY AND LATCHED?</p> <p>IS THE RIGHT CYCLE SELECTED?</p> <p>IS THERE POWER TO THE DISHWASHER? HAS A HOUSEHOLD FUSE BLOWN OR HAS A CIRCUIT BREAKER TRIPPED? REPLACE THE FUSE OR RESET THE CIRCUIT BREAKER. IF THE PROBLEM CONTINUES, CALL AN ELECTRICIAN.</p> <p>IS THE WATER SHUT-OFF VALVE (IF INSTALLED) TURNED ON?</p>
<b>DISHES DO NOT DRY COMPLETELY</b>	<p><b>NOTE:</b> PLASTIC AND ITEMS WITH NONSTICK SURFACES ARE DIFFICULT TO DRY BECAUSE THEY HAVE A POROUS SURFACE WHICH TENDS TO COLLECT WATER DROPLETS. TOWEL DRYING MAY BE NECESSARY.</p> <p>USE OF RINSE AID ALONG WITH THE HEATED DRY OPTION IS NEEDED FOR PROPER DRYING.</p> <p>PROPER LOADING OF ITEMS CAN AFFECT DRYING.</p> <p>GLASSES AND CUPS WITH CONCAVE BOTTOMS HOLD WATER. THIS WATER MAY SPILL ONTO OTHER ITEMS WHEN YOU ARE UNLOADING THE DISHWASHER.</p> <ul style="list-style-type: none"> <li>■ Unload the lower rack first.</li> <li>■ For improved results, place these items on the more slanted side of the rack.</li> </ul>
<b>NOISE</b>	<p><b>NOTE:</b> COMMON NOISES:</p> <ul style="list-style-type: none"> <li>■ SURGING SOUNDS CAN OCCUR PERIODICALLY THROUGHOUT THE CYCLE WHILE THE DISHWASHER IS DRAINING.</li> <li>■ NORMAL WATER VALVE HISSING MAY BE HEARD PERIODICALLY.</li> <li>■ A NORMAL SNAP SOUND MAY BE HEARD WHEN THE DETERGENT DISPENSER OPENS DURING THE CYCLE OR WHEN THE DOOR IS OPENED AT THE END OF THE CYCLE.</li> <li>■ IMPROPER INSTALLATION WILL AFFECT NOISE LEVELS.</li> </ul> <p>BE SURE THE FILTERS ARE PROPERLY INSTALLED.</p> <p>A THUMPING SOUND MAY BE HEARD IF ITEMS INTERFERE WITH THE WASH ARMS. READJUST THE DISHES AND RESUME THE CYCLE.</p>
<b>SPOTTING/FILMING</b>	<p>LIQUID RINSE AID IS NECESSARY FOR DRYING AND TO REDUCE SPOTTING.</p> <p>USE THE CORRECT AMOUNT OF DETERGENT.</p> <p>CONFIRM THAT THE CLOUDINESS IS REMOVABLE BY SOAKING THE ITEM IN WHITE VINEGAR FOR 5 MINUTES AND DRY THE ITEM. IF THE CLOUDINESS DISAPPEARS, IT IS DUE TO HARD WATER. ADJUST THE AMOUNT OF DETERGENT AND RINSE AID. SEE THE "DISHWASHER CARE" SECTION. IF CLOUDINESS ON GLASS DOES NOT COME CLEAR, IT IS DUE TO ETCHING.</p> <p>BE SURE THE INCOMING WATER TEMPERATURE IS SET AT 120°F (49°C).</p> <p>TRY USING THE HI TEMP WASH OPTION.</p> <p>TO REMOVE SPOTTING, RUN A VINEGAR RINSE THROUGH THE DISHWASHER.</p> <ul style="list-style-type: none"> <li>■ WASH AND RINSE THE AFFECTED DISH WARE AND LOAD INTO DISHWASHER. REMOVE ALL SILVERWARE AND METAL ITEMS. PUT 2 CUPS (500 ML) OF WHITE VINEGAR IN A 2-CUP CAPACITY MEASURING CUP AND PLACE UPRIGHT IN THE LOWER RACK. RUN A NORMAL CYCLE WITH THE HEATED DRY OPTION TURNED OFF AND NO DETERGENT. SEE THE "DISHWASHER CARE" SECTION IN FULL USER INSTRUCTIONS.</li> </ul>

**For Service Technician Use Only**

**Customer Troubleshooting Guide (From Use & Care Guide) continued**

CUSTOMER COMPLAINT	RECOMMENDED SOLUTIONS
<b>DISHWASHER DOES NOT CLEAN COMPLETELY</b>	<p>BE SURE THE DISHWASHER IS LOADED CORRECTLY. IMPROPER LOADING CAN GREATLY DECREASE THE WASHING PERFORMANCE. SEE THE “OPERATING YOUR DISHWASHER” SECTION.</p> <p>CHECK FILTER TO ENSURE IT IS PROPERLY INSTALLED. CLEAN IT IF NEEDED. SEE THE “FILTRATION SYSTEM” SECTION IN THE FULL USER INSTRUCTIONS FOR DETAILS.</p> <p>SELECT THE PROPER CYCLE FOR THE TYPE OF SOILS. THE HEAVY WASH CYCLE CAN BE USED FOR TOUGHER LOADS.</p> <p>BE SURE THE INCOMING WATER TEMPERATURE IS 120°F (49°C).</p> <p>USE THE PROPER AMOUNT OF FRESH DETERGENT. MORE DETERGENT IS NEEDED FOR HEAVIER-SOILED LOADS AND HARD WATER CONDITIONS.</p> <p>SCRAPE FOOD FROM DISHES PRIOR TO LOADING (DO NOT PRERINSE).</p> <p>SUDS CAN COME FROM:</p> <ul style="list-style-type: none"><li>■ USING THE INCORRECT TYPE OF DETERGENT, SUCH LAUNDRY DETERGENT, HAND SOAP, OR DISH DETERGENT FOR HAND-WASHING DISHES.</li><li>■ NOT REPLACING THE RINSE AID DISPENSER CAP AFTER FILLING (OR REFILLING) THE RINSE AID DISPENSER.</li><li>■ USING AN EXCESSIVE AMOUNT OF DISHWASHER DETERGENT.</li></ul>
<b>DISHWASHER DOES NOT DRAIN</b>	<p>BE SURE THE CYCLE HAS BEEN COMPLETED. IF IT HAS NOT, YOU WILL NEED TO RESUME THE CYCLE BY CLOSING THE DOOR AND PRESSING START.</p> <p>IF DISHWASHER IS CONNECTED TO A FOOD WASTE DISPOSER, BE SURE THE KNOCKOUT PLUG HAS BEEN REMOVED FROM THE DISPOSER INLET.</p> <p>CHECK FOR KINKS IN THE DRAIN HOSE.</p> <p>CHECK FOR FOOD OBSTRUCTIONS IN THE DRAIN OR DISPOSER.</p> <p>CHECK YOUR HOUSE FUSE OR CIRCUIT BREAKER.</p>

**Notes**



## Section 3: Testing

This section provides a wiring diagram, control board specifications, testing procedures and strip circuits the 18" & 24" ADA Built-In Dishwashers.

- Testing Safety
- Wiring Diagram
- General Theory of Operation
- Power Check
- Door Switch Circuit
- Control Board
- Water Inlet Valve
- Dispenser Circuit
- Heating Element
- Turbidity Sensor
- Thermistor
- Overflow Switch
- Flow Meter
- Wash Pump
- Drain Pump
- Pressure Switch
- Notes

## For Service Technician Use Only

### **⚠ DANGER**



#### Electrical Shock Hazard

Only authorized technicians should perform diagnostic voltage measurements.

After performing voltage measurements, disconnect power before servicing.

Failure to follow these instructions can result in death or electrical shock.

### **⚠ WARNING**



#### Electrical Shock Hazard

Disconnect power before servicing.

Replace all parts and panels before operating.

Failure to do so can result in death or electrical shock.

### Voltage Measurement Safety Information

When performing live voltage measurements, you must do the following:

- Verify the controls are in the off position so that the appliance does not start when energized.
- Allow enough space to perform the voltage measurements without obstructions.
- Keep other people a safe distance away from the appliance to prevent potential injury.
- Always use the proper testing equipment.
- After voltage measurements, always disconnect power before servicing.

#### IMPORTANT: Electrostatic Discharge (ESD) Sensitive Electronics

ESD problems are present everywhere. Most people begin to feel an ESD discharge at approximately 3000V. It takes as little as 10V to destroy, damage, or weaken the main control assembly. The new main control assembly may appear to work well after repair is finished, but a malfunction may occur at a later date due to ESD stress.

- Use an anti-static wrist strap. Connect wrist strap to green ground connection point or unpainted metal in the appliance

-OR-

- Touch your finger repeatedly to a green ground connection point or unpainted metal in the appliance.
- Before removing the part from its package, touch the anti-static bag to a green ground connection point or unpainted metal in the appliance.
- Avoid touching electronic parts or terminal contacts; handle electronic control assembly by edges only.
- When repackaging main control assembly in anti-static bag, observe above instructions.

#### IMPORTANT SAFETY NOTICE — “For Technicians only”

This service data sheet is intended for use by persons having electrical, electronic, and mechanical experience and knowledge at a level generally considered acceptable in the appliance repair trade. Any attempt to repair a major appliance may result in personal injury and property damage. The manufacturer or seller cannot be responsible, nor assume any liability for injury or damage of any kind arising from the use of this data sheet.

# For Service Technician Use Only

## Wiring Diagram

Schematic shown with door switch and all other normally open contacts open.

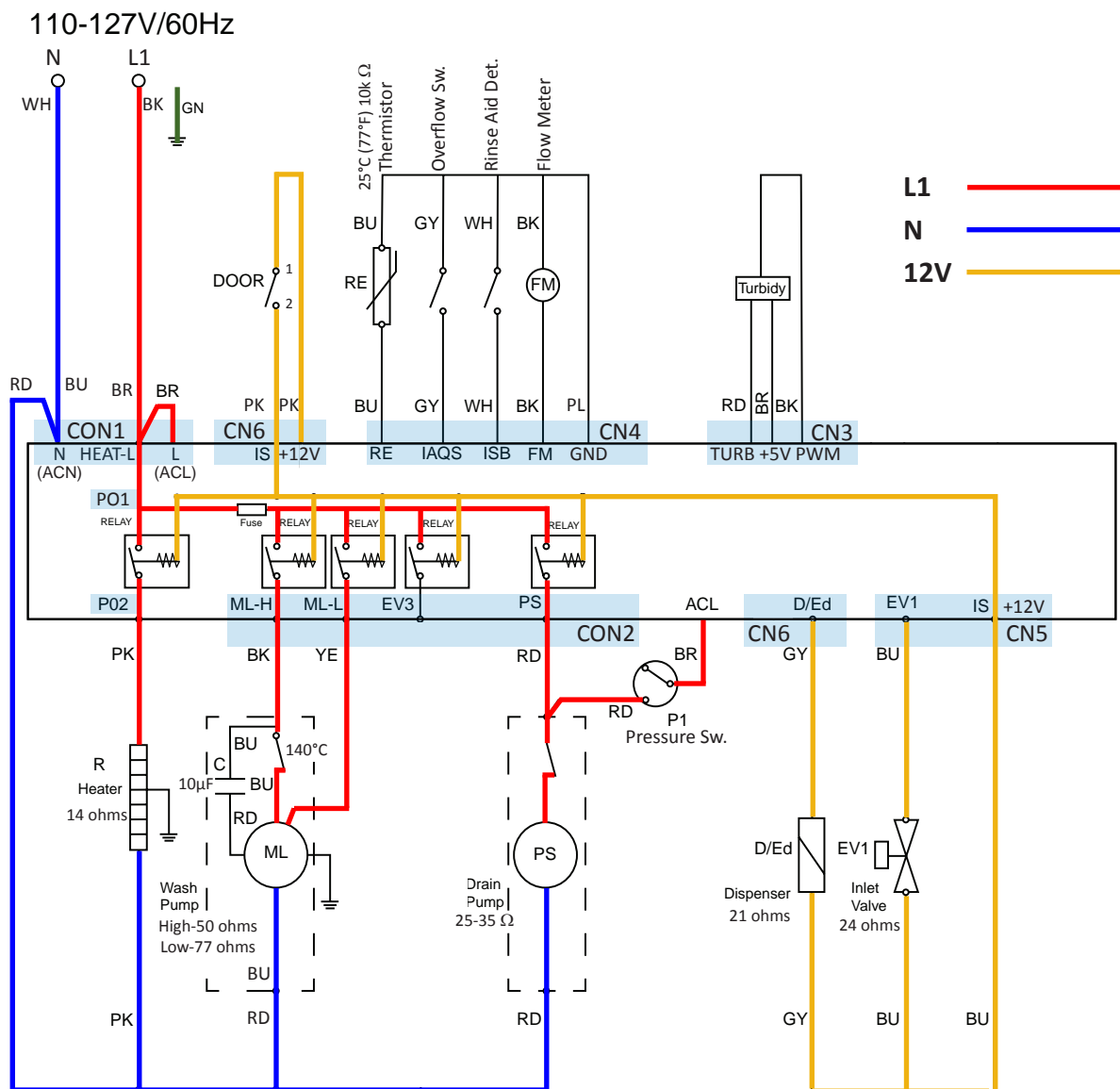

- |       |                               |      |                             |
|-------|-------------------------------|------|-----------------------------|
| ACL:  | L1 (Alternating Current)      | IS:  | Door Switch Detector (+12V) |
| ACN:  | Neutral (Alternating Current) | ISB: | Rinse Aid Detector          |
| C:    | Capacitor                     | ML:  | Wash Pump                   |
| D/Ed: | Dispenser                     | P1:  | Water Level Switch          |
| DOOR: | Door Switch                   | P2:  | Dry Heating Protect Switch  |
| EV1:  | Inlet Valve                   | PS:  | Drain Pump                  |
| FM:   | Flow Meter                    | R:   | Heater                      |
| FUSE: | Fuse (3.15A)                  | RE:  | Thermistor (NTC)            |
| IAQS: | Overflow Switch               | TUR: | Turbidity Sensor            |

## For Service Technician Use Only

**⚠ DANGER**



### Electrical Shock Hazard

**Only authorized technicians should perform diagnostic voltage measurements.**

**After performing voltage measurements, disconnect power before servicing.**

**Failure to follow these instructions can result in death or electrical shock.**

## General Theory of Operation

Refer to Wiring Diagram on page 3-3.

Neutral and L1 (AC voltage) enters the Control Board at CON1, pins 1 & 2 respectively. AC is converted to DC voltage at the Low Volts Power Supply (LVPS). Supplies include +12 and +5 VDC, and DC GND (REF). These low voltage supplies are used to provide power to the microprocessors and board components, power the sensors and energize the AC relays.

The 12 VDC is vital to the operation of the dishwasher. This supply is necessary to operate all 120 VAC loads in the dishwasher, whether they are connected to a relay or controlled by TRIACs. 12 VDC is generated by the power supply and flows through the door switch—when closed—to be available to the heater relay, wash motor relays, and the drain pump relay. A relay coil becomes energized when the control closes the LV drive circuit for a specific relay completing 12V pathway, which in turn closes the relay switch providing AC to the load.

## Power Check

This test checks for incoming and outgoing power to and from the control board. This test assumes that proper voltages is present at the outlet or direct connect cable.

### Test Procedure

1. Unplug dishwasher or disconnect power.
  2. Remove access panel.
  3. Remove terminal box cover.
  4. With a voltmeter set to AC, insert black probe inside white wire screw nut (N) and insert red probe inside black wire screw nut (L1).
  5. Plug in dishwasher or reconnect power.
    - If 120 VAC is present, unplug dishwasher or disconnect power and proceed to step 6.
    - If 120 VAC is not present, have customer correct power problem at outlet or breaker.
  6. Remove the control board cover.
  7. Locate connector CON 1.
  8. With a voltmeter set to AC, connect leads across the two pins (“N” and “L”) on CON 1.
  9. Plug in dishwasher or reconnect power.
    - If 120 VAC is present, go to step 10.
    - If 120 VAC is not present, check for open connection between terminal block and control. Repair as needed.
  10. Verify DC Supplies
    - **5 VDC** is used to power IC’s and micro-processors on the circuit board as well as provide power to the sensors.
      - If **5 VDC** were missing, the control and Turbidity Sensor would not function. To verify  $5V \pm 5\%$ , with a voltmeter set to DC, connect the black lead to CN4-2 (DC GND) and the red lead to CN3-1 (+5V).
    - **12 VDC** is used to actuate the heater, drain and wash pump relays as well as the dispenser and water inlet valve.
      - If **12 VDC** was missing, the heater, pumps, and all other loads would not turn on. To verify  $12V \pm 5\%$ , with a voltmeter set to DC, connect the red lead to CN6-1 (12V) and black lead to CN4-2 (DC GND).
- Troubleshooting Missing DC Supplies:** Refer to the wiring diagram on page 3-4 when troubleshooting the DC supplies. If 5 VDC or 12 VDC is missing on the control, unplug dishwasher or disconnect power, and then disconnect all components/loads from the control relying on the missing or loaded supply. Plug in dishwasher or reconnect power and check if the DC supply has returned.
- If not, replace the control.
  - If it has, turn off dishwasher and reconnect one connector at a time until the component loading down that supply has been identified.
11. Unplug dishwasher or disconnect power.
  12. Reassemble all parts and panels.

## For Service Technician Use Only

**⚠ DANGER**



### Electrical Shock Hazard

Only authorized technicians should perform diagnostic voltage measurements.

After performing voltage measurements, disconnect power before servicing.

Failure to follow these instructions can result in death or electrical shock.

## Door Switch Circuit

Perform the following checks if the dishwasher does not detect the door open or closed. This test will check the wiring to the door switch and the door switch itself. The following items are part of the door switch circuit.

- Harness/Connection
- Door Switch/Latch Assembly
- Control Board

### Test Procedure

1. Check for improper installation of the dishwasher or leveling. Check door latch mechanism for obstructions or binding. Verify door seal is seated properly. Check for interference between dish racks and door. Repair as necessary.
2. Unplug dishwasher or disconnect power.
3. Remove the access panel and the control board cover. Remove or fold back plastic cover over door switch.

4. Check door switch contacts and all connections in the door switch circuit. Visually check that the **CN6** connector on the control and the door latch terminals are securely installed.
  - If visual check passes, go to step 5.
  - If any of the connectors are not inserted properly, reconnect and retest door latch/switch.
5. Disconnect connector **CN6** from the control board.
6. Using an ohmmeter, measure across CN6, pins 1 and 3 (12V & IS respectively) with the door closed, strike completely in latch mechanism (switch closed).
  - If 3 ohms or less is measured, proceed to step 7.
  - If high resistance is measured when door is closed, check for loose connections and repair as needed.
7. Using an ohmmeter, measure across CN6, pins 1 and 3 (12V & IS respectively) with the door open, strike removed from latch mechanism (switch open).
  - If reading is infinite, go to step 8.
  - If reading shows continuity, or door switch is damaged, replace door switch and retest.
8. Set voltmeter to DC and connect red lead to CN6, pin 1 (12V) and black lead to CN4, pin 2 (DC GND) on the control board.
9. Plug in dishwasher or reconnect power and with door open, verify that 12 VDC is present across CN6-1 and CN4-2.
  - If 12 VDC is not present, replace the control and retest.
  - If 12 VDC is present, proceed to step 10.
10. Reconnect CN6 & CN4 to control board and perform Diagnostic Cycle to verify operation.
11. Unplug dishwasher or disconnect power.
12. Reassemble all parts and panels.
13. Plug in dishwasher or reconnect power.

## STRIP CIRCUIT - DOOR SWITCH

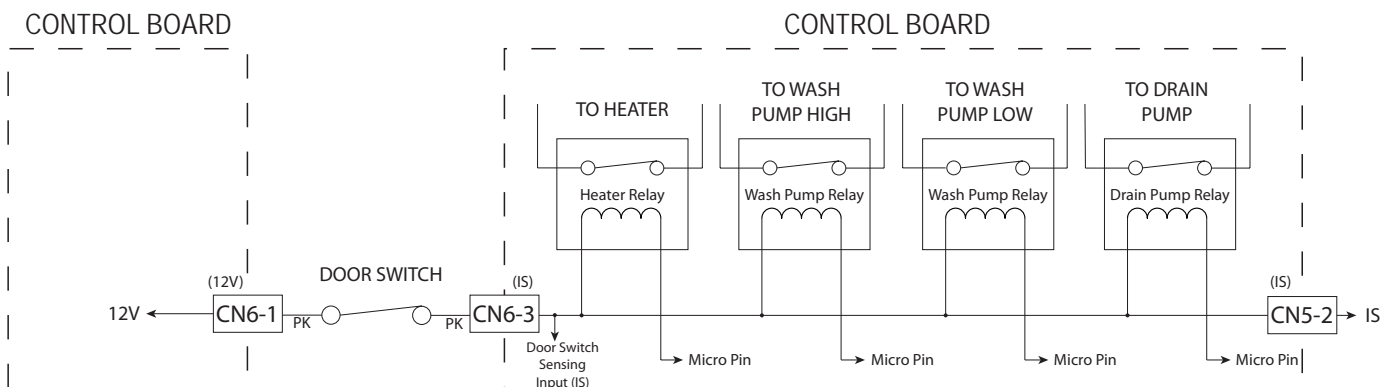



Figure 1 - Door Switch Strip Circuit

## For Service Technician Use Only

<b>⚠ DANGER</b>

<b>Electrical Shock Hazard</b>
<b>Only authorized technicians should perform diagnostic voltage measurements.</b>
<b>After performing voltage measurements, disconnect power before servicing.</b>
<b>Failure to follow these instructions can result in death or electrical shock.</b>

### Component Testing

#### TESTING DISHWASHER COMPONENTS FROM THE CONTROL BOARD

Before testing any of the components, perform the following checks:

- The most common cause for misdiagnosed control failure is poor connections. Therefore, disconnecting, inspecting and reconnecting wires will be necessary throughout test procedures.
- All tests/checks should be made with a VOM or DVM having a sensitivity of 20,000 ohms-per-volt DC, or greater.
- Check all connections before replacing components, looking for broken or loose wires, failed terminals, or wires not pressed into connectors far enough.
- Voltage checks must be made with all connectors attached to the boards.
- Resistance checks must be made with power cord unplugged or power disconnected, and with wiring harness or connectors disconnected from the control.
- The testing procedures in this section may require the use of needle probes to measure voltage. Failure to use needle probes will damage the connectors.

### Control Board

#### SPECIFICATIONS

**ELECTRICAL SUPPLY:**

(Under Load): 60Hz 120V AC

**SUPPLY WATER FLOW RATE:**

To fill 4 qt (3.8 L) in 36 seconds, 100 psi maximum, 20 psi minimum.

**SUPPLY WATER TEMPERATURE:**

120°F (49°C) (Before starting a cycle, run water from sink faucet until hot.)

**WATER CHARGE:**

4 qt. (3.8 L) Approximate

**LOWER SPRAY ARM ROTATION:**

20 TO 40 rpm

**UPPER SPRAY ARM ROTATION:**

15 TO 40 rpm

# For Service Technician Use Only

## CONTROL BOARD - CONNECTOR LOCATIONS

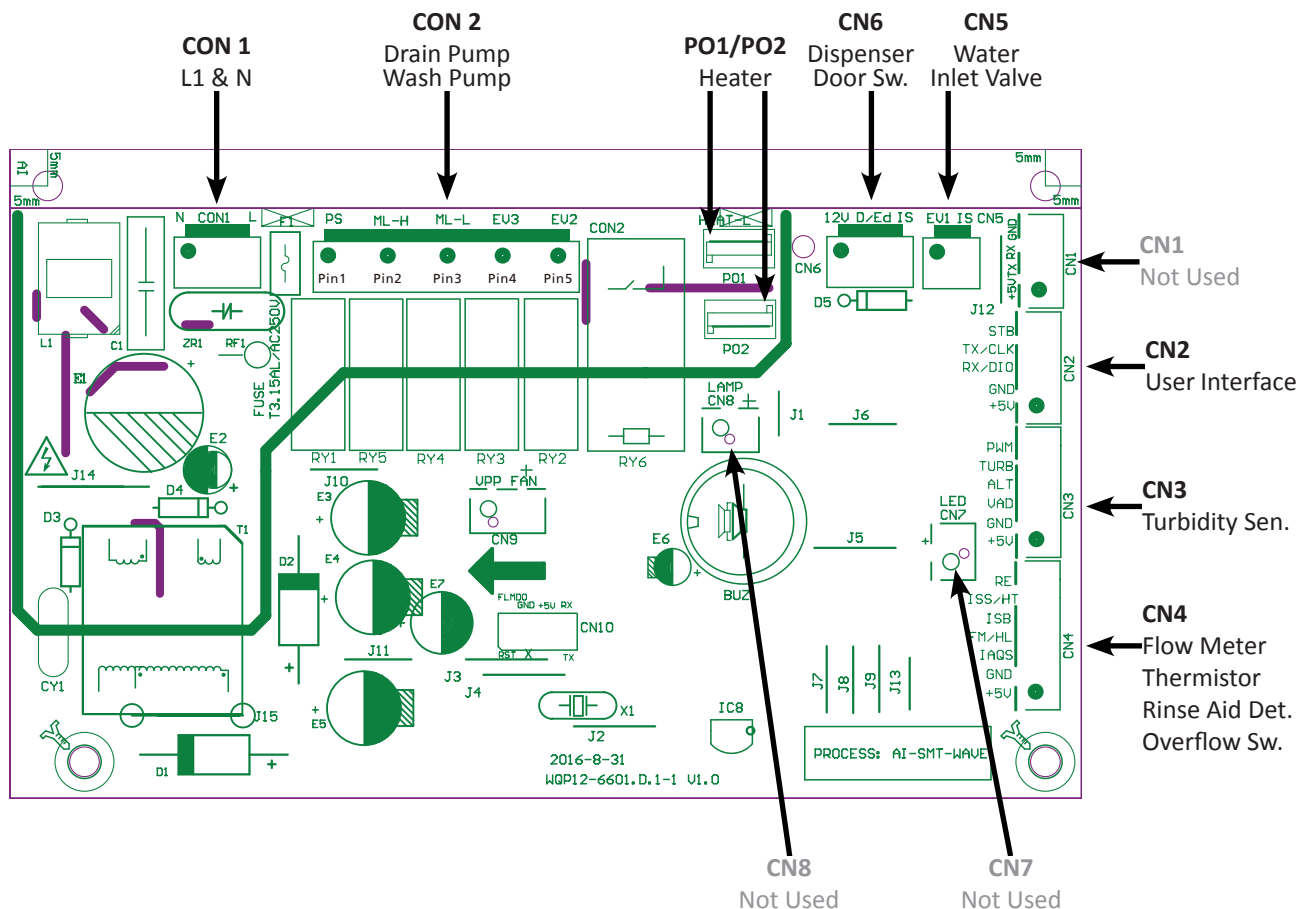

## CONTROL BOARD - CONNECTOR IDENTIFICATION

### CON1: L1, N

- N - Neutral In
- L - Line 1 In

### CON2: Drain & Wash Pump

- Pin1 - Drain Pump (Pressure Sw.)
- Pin2 - Wash Pump - High speed
- Pin3 - Wash Pump - Low speed
- Pin4 - Not used
- Pin5 - Not used

### PO1/PO2: Heater

CN1: Not used

CN2: User Interface

CN3: Turbidity Sensor

CN4: Flow Meter/Thermistor/Rinse Aid Detector/Overflow Sw.

CN5: Water Inlet Valve

CN6: Dispenser and Door Switch

CN7: Not used

CN8: Not used

## For Service Technician Use Only

**⚠ DANGER**



**Electrical Shock Hazard**

**Only authorized technicians should perform diagnostic voltage measurements.**

**After performing voltage measurements, disconnect power before servicing.**

**Failure to follow these instructions can result in death or electrical shock.**

- If outside the range, replace the inlet valve.
- If an open circuit is detected, check connections and harness continuity between control and inlet valve (see Figure 1). If good, replace the inlet valve.



Figure 1 - Water Inlet Valve

### Water Inlet Valve

This test will check the wiring and components in the fill circuit. The following items are part of the fill circuit.

- Harness/Connection
- Water Inlet Valve
- Control Board

#### Test Procedure

1. Verify water supply is turned on and supply line is adequate. Check for water siphoning out of the dishwasher (improper drain connection). Check for debris in water line or fill valve inlet screen. Check for proper float switch operation. Repair as necessary.
2. Unplug dishwasher or disconnect power.
3. Remove access panel. Remove control board cover to access control board.
4. Unplug connector **CN5** from control board.
5. Check the inlet valve and harness—using an ohmmeter, measure the resistance between CN5-1 and CN5-2.
  - If the resistance is approximately 24 ohms, the water inlet valve and harness are good. Go to step 7.

6. Reconnect CN5 to control board.
7. Set voltmeter to DC and connect lead black lead to CN5-1 (EV1) and red lead to CN5-2 (IS) on the control board. Plug in dishwasher or reconnect power.
8. Start the Service Mode Test and at step-1 measure for 12 VDC out of the control between CN5-1 and CN5-2. (Refer to the Water Inlet Valve Strip Circuit below.)

**IMPORTANT: The Water Inlet Valve must be connected to the control board to measure voltage accurately!!!**

- If 12 VDC is not measured, replace the control board and retest.
  - If 12 VDC is measured and water inlet valve is energized, go to step 9.
9. Check water level switch, harness, and connections. Replace or repair as necessary.
  10. Unplug dishwasher or disconnect power.
  11. Reassemble all parts and panels.
  12. Plug in dishwasher or reconnect power and run Service Mode Test to verify repair.

#### STRIP CIRCUIT - WATER INLET VALVE

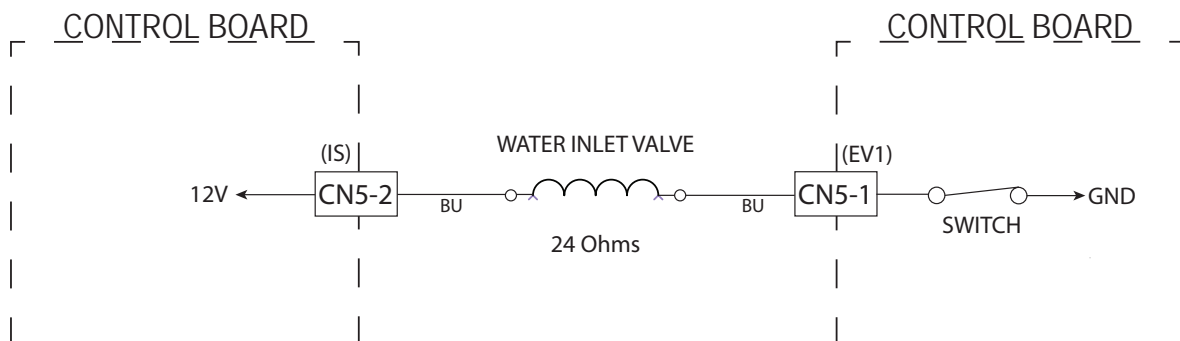



Figure 2 - Water Inlet Valve Strip Circuit



## For Service Technician Use Only

**⚠ DANGER**



**Electrical Shock Hazard**

**Only authorized technicians should perform diagnostic voltage measurements.**

**After performing voltage measurements, disconnect power before servicing.**

**Failure to follow these instructions can result in death or electrical shock.**

### Test Procedure

1. Check for obstructions or mechanical binding preventing the dispenser lid from opening. Repair or replace as necessary.
2. Unplug dishwasher or disconnect power.
3. Remove access panel. Remove control board cover to access control board.
4. Unplug connector CN6 & CN5 from the control board.
5. Check the dispenser and harness—using an ohmmeter, measure the resistance between CN6-2 (D/Ed) and CN5-2 (IS).
  - If the resistance is approximately 21 ohms, the dispenser solenoid and harness are good. Go to step 7.
  - If outside the range, replace the dispenser assembly.
  - If an open circuit is detected, check connections and harness continuity between control and dispenser. If good, replace the dispenser assembly.
6. Reconnect CN6 & CN5 to control board.
7. Set voltmeter to DC and connect black lead to CN6-2 (D/Ed) and red lead to CN5-2 (IS) on the control board. Plug in dishwasher or reconnect power.
8. Start the Service Mode Test and at step-3 measure for 12 VDC out of the control between CN6-2 and CN5-2. (Refer to the Dispenser Strip Circuit below.)
 

**IMPORTANT: The Dispenser must be connected to the control board to measure voltage accurately!!!**

  - If 12 VDC is not measured, replace the control board and retest.
  - If 12 VDC is measured and dispenser is energized, go to step 9.
9. Unplug dishwasher or disconnect power.
10. Reassemble all parts and panels.
11. Plug in dishwasher or reconnect power and run Service Mode Test to verify repair.

### Dispenser Circuit

The detergent/rinse module automatically dispenses both the detergent and the rinse agent at the appropriate times. The module is activated five times during a wash cycle. Detergent is dispensed at the beginning of the main wash cycle for one time and rinse agent at the beginning of the final rinse for four times.

This test will check the wiring to the dispenser and the dispenser solenoid itself. The following items are part of the dispenser circuit.

- Harness/Connection
- Dispenser Solenoid
- Control Board

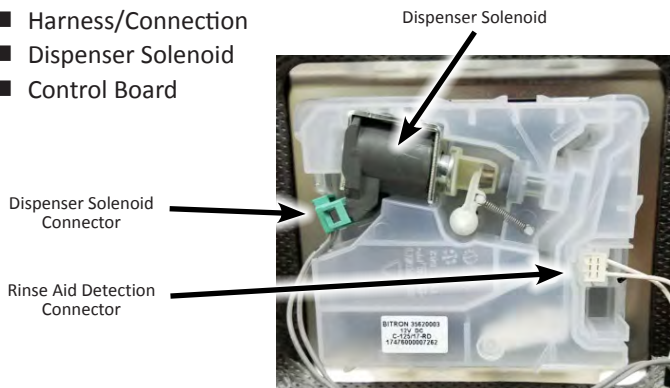

Figure 1 - Dispenser Assembly

### STRIP CIRCUIT - DISPENSER

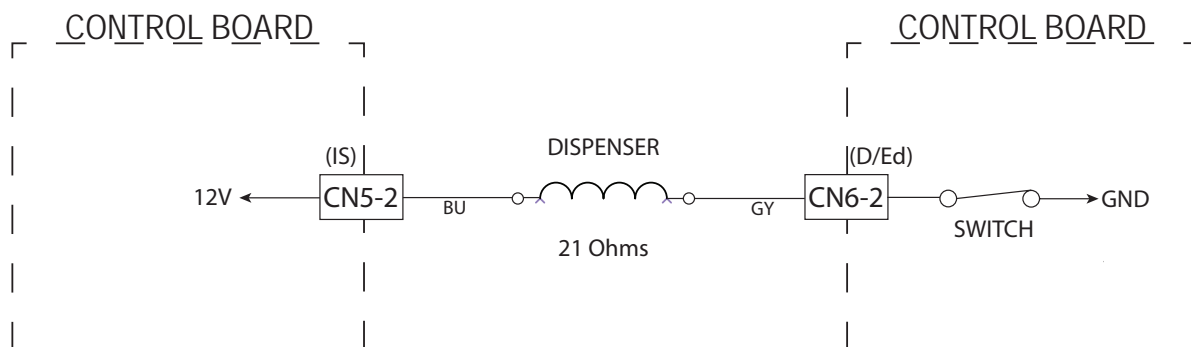



Figure 2 - Dispenser Strip Circuit

## For Service Technician Use Only

⚠ DANGER



Electrical Shock Hazard

**Only authorized technicians should perform diagnostic voltage measurements.**

**After performing voltage measurements, disconnect power before servicing.**

**Failure to follow these instructions can result in death or electrical shock.**

6. Visually check the wire connections between the control board and heater element. If the connections look good, check for continuity across the heater element.
  - Replace heater element if it is electrically open.
  - Repair or replace wire harness if test fails continuity.
7. Reconnect **P02** and **CON1** to control board.
8. Set voltmeter to AC and connect leads to P02 and CON1 on the control board. Plug in dishwasher or reconnect power.
9. Start the Service Mode Test and at step-2 measure for AC out of the control between P02 and CON1 using a voltmeter set to AC.
  - If 120 VAC is measured and heater element is on, go to step 10.
  - If no AC voltage is measured, replace control board.
10. Perform Service Mode Test to verify repair.
11. Unplug dishwasher or disconnect power.
12. Reassemble all parts and panels.
13. Plug in dishwasher or reconnect power.

### Heating Element

This test will check the wiring to the heater element, the control board, and the heating element itself. The following items are part of the heater circuit.

- Harness/Connection
- Heater Element
- Control Board

### Test Procedure

1. Unplug dishwasher or disconnect power.
2. Remove access panel. Remove control board cover to access control board.
3. Lay the dishwasher on its back. Use a small flat-blade screwdriver to unclip snaps around the drip-pan. Remove drip-pan/float switch to access under tub components.
4. Disconnect **P02** and **CON1** from the control board.
5. Using an ohmmeter, measure resistance between P02 and CON1-1 (Neutral).
  - If an open circuit is detected, go to step 6.
  - If the resistance is approximately 14 ohms, go to step 7.

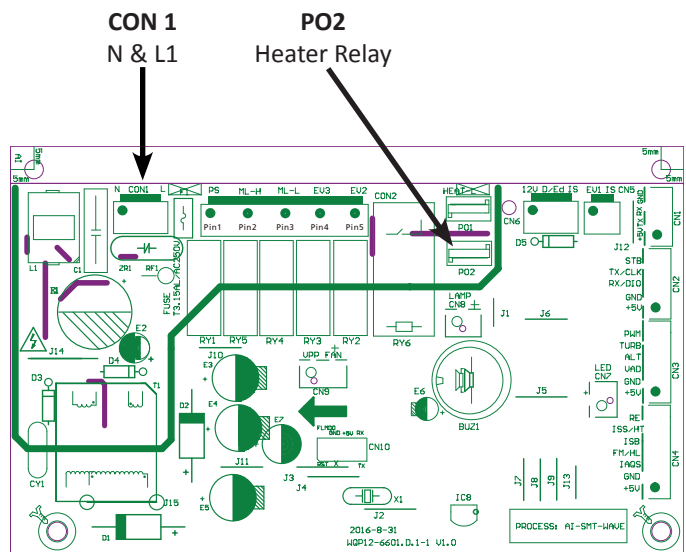

Figure 1 - Heater Connectors

### STRIP CIRCUIT - HEATER

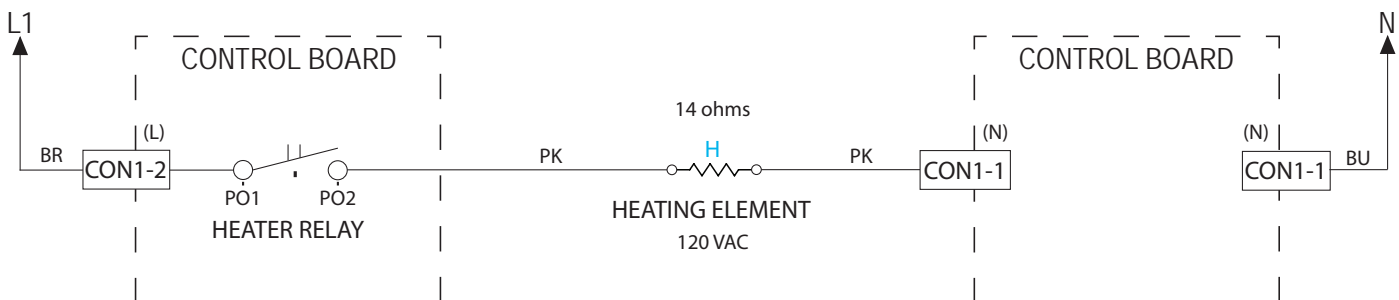



Figure 2 - Heater Strip Circuit

## For Service Technician Use Only

**⚠ DANGER**



**Electrical Shock Hazard**

**Only authorized technicians should perform diagnostic voltage measurements.**

**After performing voltage measurements, disconnect power before servicing.**

**Failure to follow these instructions can result in death or electrical shock.**

This test will check the wiring to the Turbidity Sensor, which measures the cloudiness or haziness of the water caused by the amount of suspended solids and particles in the water. The following items are part of the turbidity sensing circuit.

- Harness/Connection
- Turbidity Sensor
- Control Board

### Test Procedure

1. Check the Turbidity Sensor and electrical connections by performing the “Service Mode Test” on page 2-3. The following steps assume that this step was unsuccessful.
2. Unplug dishwasher or disconnect power.
3. Remove access panel. Remove control board cover to access control board.
4. Lay the dishwasher on its back. Use a small flat-blade screwdriver to unclip snaps around the drip-pan. Remove drip-pan/float switch to access under tub components.
5. Test for 5 VDC—With a voltmeter set to DC, connect the black lead to CN4-2 (GND) and the red lead to CN3-1 (+5V).
6. Plug in dishwasher or reconnect power.
7. Measure for 5 VDC out of the control between CN4-2 (GND) and CN3-1 (+5V).
  - If 5 VDC is measured the control is functioning, replace the Turbidity Sensor and retest.
  - If 5 VDC is measured, replace the control board and retest.
8. Unplug dishwasher or disconnect power.
9. Reassemble all parts and panels.
10. Plug in dishwasher or reconnect power and run “Service Mode Test” to verify repair.

## Turbidity Sensor

### Overview

The turbidity sensor is located under the tub and is attached to the sump with two snap clips (see Figure 1). During the pre-wash cycle, the turbidity sensor senses the water and chooses the appropriate wash cycle.

**NOTE:** If the turbidity sensor is not functioning, the dishwasher will continue to operate, but choose a default wash cycle.

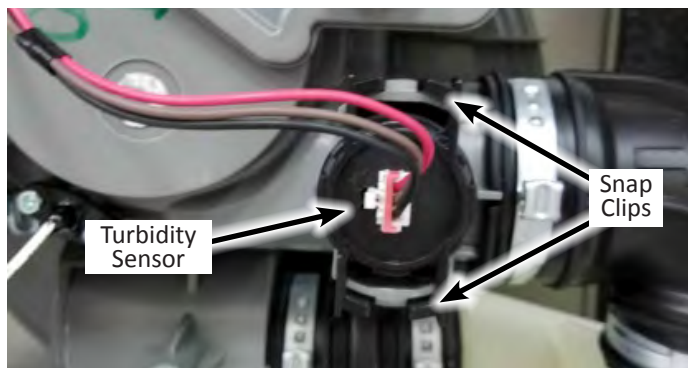

Figure 1 - Turbidity Sensor Location

### STRIP CIRCUIT - TURBIDITY SENSOR

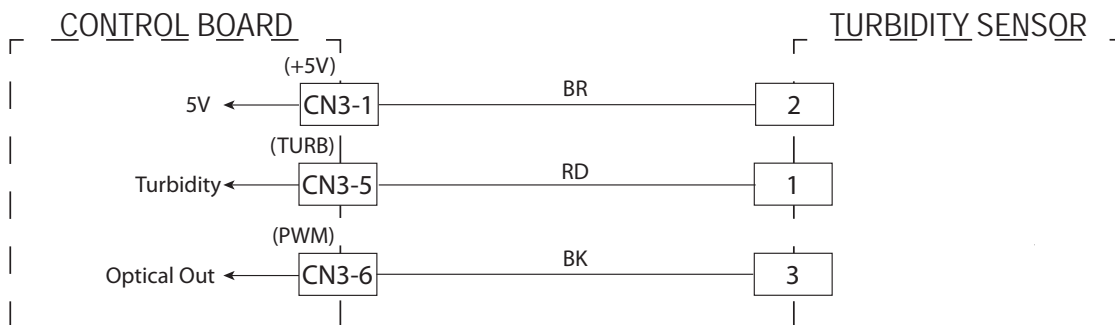



Figure 2 - Turbidity Sensor Circuit

## For Service Technician Use Only

**⚠ WARNING**



**Electrical Shock Hazard**  
**Disconnect power before servicing.**  
**Replace all parts and panels before operating.**  
**Failure to do so can result in death or electrical shock.**

### Test Procedure

This test will check the wiring to the Thermistor, the control board, and the thermistor itself. The following items are part of the Thermistor circuit.

- Harness/Connection
- Thermistor
- Control Board

1. Check the operation of the Thermistor in Service Mode. (See “note” on step #2 on Service Mode Chart, page 2-3.)
2. Unplug dishwasher or disconnect power.
3. Remove access panel. Remove control board cover to access control board.
4. Lay the dishwasher on its back. Use a small flat-blade screwdriver to unclip snaps around the drip-pan. Remove drip-pan/float switch to access under tub components.
5. Disconnect **CN4** from the Control Board.
6. Using an ohmmeter, measure resistance between CN4-2 (GND) and CN4-7 (RE). The following table provides approximate room and hot water temperatures and their associated resistance values.

TEMP °F (°C)	RES RANGE k ohms
77° F (25° C)	10k ohms
140° F (60° C)	3k ohms

**NOTE:** All thermistor resistance measurements must be made while dishwasher is unplugged or disconnected from power and connector **CN4** removed from control.

- If the thermistor resistance does not agree with the table, replace the Thermistor.
- If an open circuit is detected, check connections and harness continuity between control and thermistor. If good, replace the thermistor.
- If the thermistor resistance is OK , the thermistor is good. Replace the control board and retest.

7. Unplug dishwasher or disconnect power.
8. Reassemble all parts and panels.
9. Plug in dishwasher or reconnect power and run Service Mode Test to verify repair.

### Thermistor

The thermistor is located under the tub and is attached to the back side of the sump with two screws. See Figure 1.

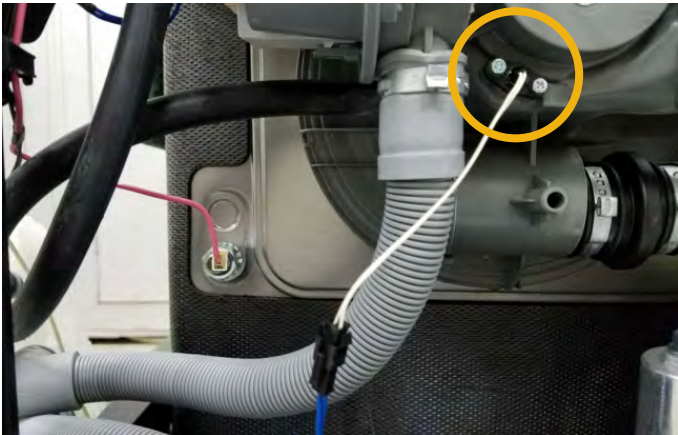

Figure 1 - Location of Thermistor

During the hot wash cycle, the thermistor senses the water temperature and turns the heating element off.

**NOTE:** If the thermistor is not operating, the hot wash cycle will set a default time for the heating element to cycle.

### STRIP CIRCUIT - THERMISTOR

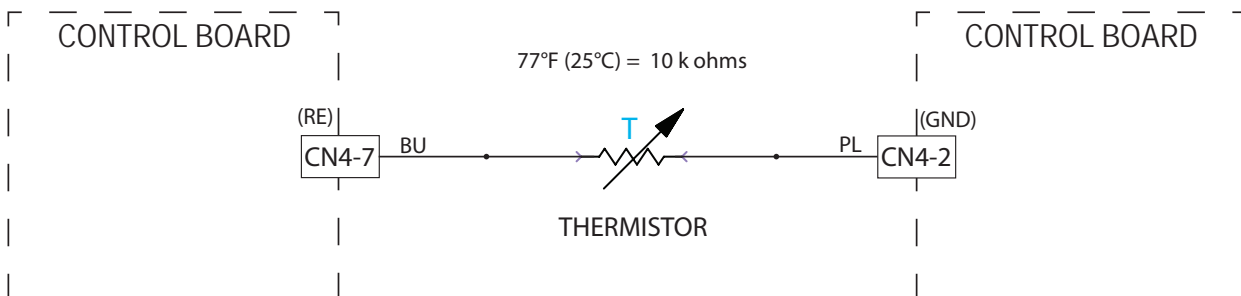



Figure 2 - Thermistor Circuit

## For Service Technician Use Only

**⚠ WARNING**



**Electrical Shock Hazard**

**Disconnect power before servicing.**

**Replace all parts and panels before operating.**

**Failure to do so can result in death or electrical shock.**

drip pan, the water will lift the foam float and open the switch. This will signal the control to shut off the water inlet valve and activate the drain pump. An “E4” Overflow Error Code will be generated.

**NOTE:** If the overflow switch is disconnected or open, the dishwasher will not start a cycle or perform diagnostics.

### Test Procedure

This test will check the wiring to the Overflow Switch, the switch itself, and the control board. The following items are part of the Overflow circuit.

- Harness/Connection
- Overflow Switch
- Control Board

## Overflow Switch

The overflow switch is located under the tub and is attached to the drip pan (see Figure 1).

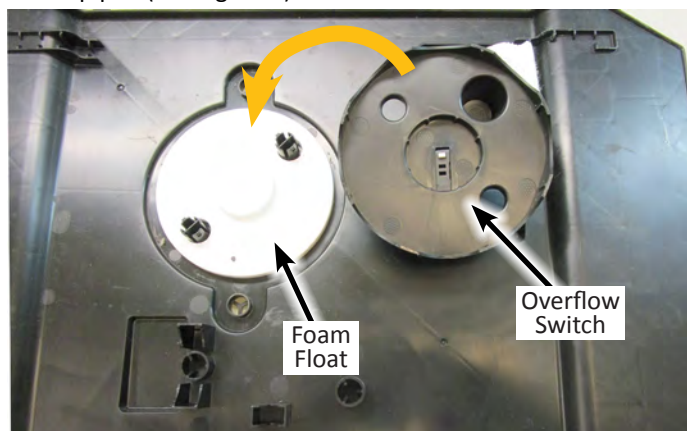

Figure 1 - Overflow Switch Assembly

The overflow switch is a normally closed switch that is used to detect a possible overflow condition. If water drips onto the

1. Unplug dishwasher or disconnect power.
2. Remove access panel. Remove control board cover to access control board.
3. Lay the dishwasher on its back. Use a small flat-blade screwdriver to unclip snaps around the drip-pan. Pull away drip-pan but keep float switch harness connected.
4. Disconnect **CN4** from the Control Board.
5. Check the overflow switch—using an ohmmeter, measure the resistance between CN4-2 and CN4-3 with the overflow switch closed/float down (normal position).
  - If 3 ohms or less is measured, go to step 6.
  - If an open circuit or high resistance is measured, check connections and harness continuity between the control board and overflow switch. If harness is good, replace switch and retest.
6. Using an ohmmeter; measure the resistance between CN4-2 and CN4-3 with the overflow switch open/float up.
  - If reading is infinite, go to step 7.
  - If 3 ohms or less is measured, or float/overflow switch is damaged, replace switch and retest.
7. If the preceding steps did not correct the overflow switch problem, replace the control board and retest.
8. Unplug dishwasher or disconnect power.
9. Reassemble all parts and panels.
10. Plug in dishwasher or reconnect power and run Service Mode Test on page 2-3 to verify repair.

## STRIP CIRCUIT - OVERFLOW SWITCH

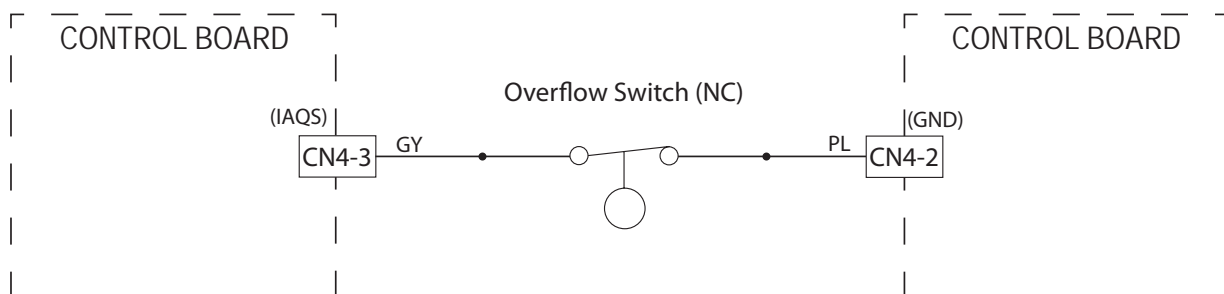



Figure 2 - Overflow Circuit



## For Service Technician Use Only

**⚠ DANGER**



**Electrical Shock Hazard**

**Only authorized technicians should perform diagnostic voltage measurements.**

**After performing voltage measurements, disconnect power before servicing.**

**Failure to follow these instructions can result in death or electrical shock.**

5. Remove access panel. Remove control board cover to access control board.
6. Unplug connector **CN4** from control board.
7. With an ohmmeter, check the harness between the Control Board (**CN4**) and flow meter for continuity.
  - If there is continuity, go to step 8.
  - If there is no continuity, replace the harness.
8. With voltmeter set to DC, connect leads to CN4, pins 2 and 4. Run a wash cycle and measure the flow meter voltage when the inlet water valves open and water is entering the washer. A nominal reading of approximately 1.9 VDC should be measured when water is flowing through the flow meter (voltage will vary depending on household water pressure). No water flowing = 0V.
  - If voltage is present, the flow meter is working properly. Go to step 9.
  - If voltage is not present when water is entering the washer, replace the flow meter.
9. If the preceding steps did not correct the fill problem, replace the Control Board.
  - Unplug dishwasher or disconnect power.
  - Replace the Control Board.
  - Reassemble all parts and panels.
  - Perform the “Service Mode Test” on page 2-3 to verify repair.

### Flow Meter

#### Test Procedure

This test checks the electrical connections to the flow meter and the flow meter itself.

1. Perform the “Service Mode Test” on page 2-3. If error code **E1** is generated, the dishwasher is detecting less than 3 L of water after 30 seconds of starting the test. Go to step 2.
2. Did the water inlet valve turn on and was water heard entering the tub?
  - No, the valve did not turn on. Go to Water Inlet Valve test on page 3-8.
  - Yes, the valve turned on, but no water entered the drum. Go to step 3.
  - Yes, the valve turned on and water entered the drum. Go to step 4.
3. Verify the water supply is turned on and supply line is adequate. Check for debris in the water line or fill valve inlet screen. Repair as necessary and retest.
4. Unplug dishwasher or disconnect power.

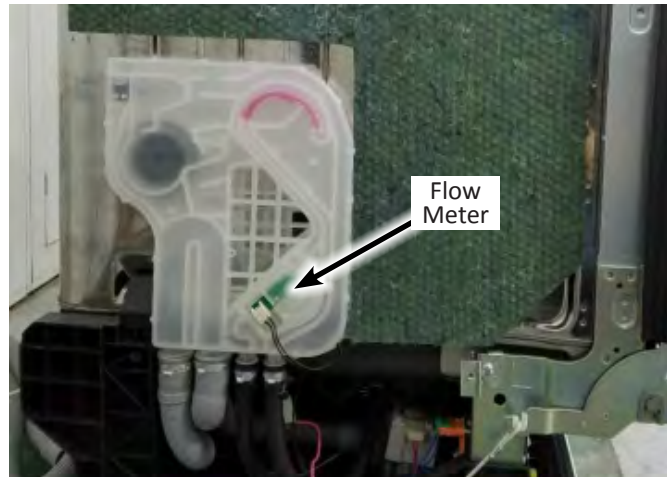

Figure 1 - Flow Meter in Air-break Assembly

#### STRIP CIRCUIT - FLOW METER

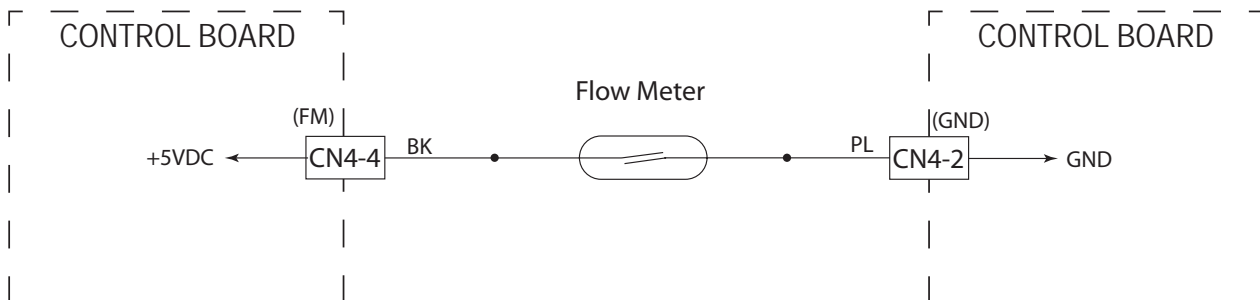

Figure 2 - Flow Meter Strip Circuit

## For Service Technician Use Only

**⚠ DANGER**



### Electrical Shock Hazard

**Only authorized technicians should perform diagnostic voltage measurements.**

**After performing voltage measurements, disconnect power before servicing.**

**Failure to follow these instructions can result in death or electrical shock.**

## Wash Pump

This test will check the wiring to the wash/rinse motor and the motor itself. The following items are part of the wash/rinse motor circuit.

- Harness/Connection
- Wash Pump & Capacitor
- Control Board

### Test Procedure

1. Check the tub and sump for anything that may be impeding water flow. Inspect and if necessary clean the coarse-filter system. Also, inspect spray arm water nozzles and clean if needed.
  2. Check the wash pump and electrical connections by performing the "Service Mode Test" on page 2-3. The following steps assume that this step was unsuccessful.
  3. Unplug dishwasher or disconnect power.
  4. Remove access panel. Remove control board cover to access control board.
  5. Lay the dishwasher on its back. Use a small flat-blade screwdriver to unclip snaps around the drip-pan. Remove drip-pan/float switch to access under tub components.
  6. Unplug connector **CON1** and **CON2** from control board.
7. Check the wash pump—using an ohmmeter, measure the resistance across the high and low pump coils as shown in the following chart.
 

MOTOR COIL	PINOUTS	RESISTANCE
High Coil	CON2, Pin 2 to CON1, pin 1	44-54 ohms
Low Coil	CON2, Pin 3 to CON1, pin 1	69-87 ohms

    - If the resistance is within range, the wash pump and harness are good. Go to step 8.
    - If far outside the range, replace the wash pump.
    - If an open circuit is detected, check connections and harness continuity between control and wash pump. If good, replace the wash pump.
  8. Reconnect **CON1** and **CON2** to control board.
  9. Test Wash Pump High Coil—Set voltmeter to AC and connect leads to CON2, pin 2 and CON1, pin 1 on the control board. Plug in dishwasher or reconnect power.
  10. Start the Service Mode Test and at the proper step measure for AC out of the control between CON2-2 and CON1-1. (Refer to Wash Motor Strip Circuit below.)
    - If no AC voltage is measured, replace the control board and retest.
    - If 120 VAC is measured and wash pump is not running, go to step 12.
    - If 120 VAC is measured and wash pump is running, go to step 14.
  11. Unplug dishwasher or disconnect power. Repeat steps 9 and 10 for the Wash Pump Low Coil. Use pinouts **CON2-3** and **CON1-1**.
  12. Test the wash pump capacitor. **NOTE:** A faulty capacitor may cause the motor to "hum," not start, or start slowly.
    - a. Discharge the capacitor by touching the leads of a 20,000  $\Omega$  resistor to the two terminals.
    - b. Disconnect the wires from the capacitor terminals.
    - c. With an ohmmeter, measure across the terminals and note reading.
      - If a steady increase in resistance is noted, capacitor is good. Replace wash motor assembly and retest.
      - If the capacitor is either shorted or open, replace capacitor. and retest.
  13. If the preceding steps did not correct the wash/rinse motor problem, replace the control board.
  14. Unplug dishwasher or disconnect power.
  15. Reassemble all parts and panels.
  16. Plug in dishwasher or reconnect power and run "Service Mode Test" to verify repair.

### STRIP CIRCUIT - WASH PUMP

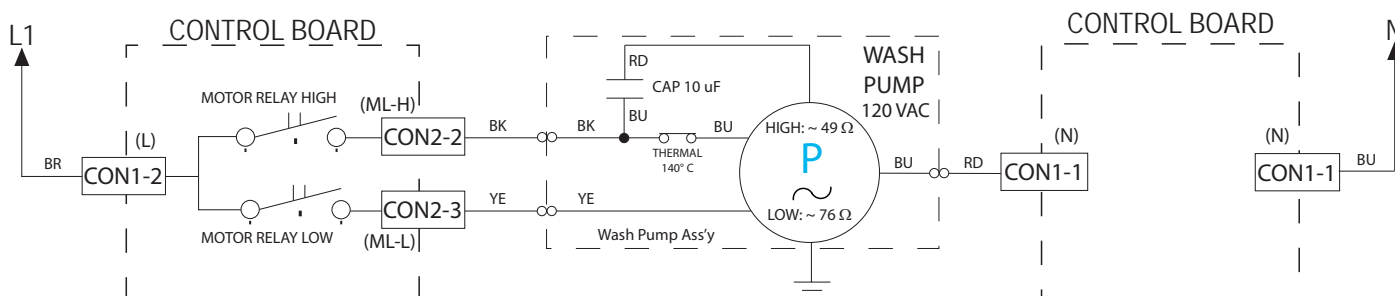



Figure 2 - Wash Pump Strip Circuit

## For Service Technician Use Only

**⚠ DANGER**



**Electrical Shock Hazard**

**Only authorized technicians should perform diagnostic voltage measurements.**

**After performing voltage measurements, disconnect power before servicing.**

**Failure to follow these instructions can result in death or electrical shock.**

### Drain Pump

The drain pump is located under the tub and operates on 120 VAC. It is energized for the first 60 seconds of a new cycle and 90 seconds after the wash pump shuts down to remove any water in the dishwasher sump. The drain pump forces water out of the drain line. A check valve flapper on the drain pump prevents the dirty water from reentering the sump.

This test will check the wiring to the drain pump and the drain pump itself. The following items are part of the drain pump circuit.

- Harness/Connection
- Drain Pump
- Control Board

#### Test Procedure

1. Verify that drain hose or drain path is not obstructed. Check for blockage from sump check valve to customer's plumbing. Check for plugged hoses, plugged garbage disposal, or disposal plug not knocked out. Repair as needed.
2. Check the drain pump and electrical connections by performing "Service Mode Test" on page 2-3. The following steps assume that this step was unsuccessful.

3. Unplug dishwasher or disconnect power.
4. Remove access panel. Remove control board cover to access control board.
5. Lay the dishwasher on its back. Use a small flat-blade screwdriver to unclip snaps around the drip-pan. Remove drip-pan/float switch to access under tub components.
6. Unplug connector **CON2** from control board.
7. Check the drain motor—using an ohmmeter, measure the resistance between CON2-1 and CON1-1.
  - If the resistance is between 25-35 ohms, the drain motor and harness are good. Go to step 8.
  - If far outside the range, replace the drain pump.
  - If an open circuit is detected, check connections and harness continuity between control and drain pump. If good, replace the drain pump.
8. Reconnect **CON2** to control board.
9. Set voltmeter to AC. Connect red lead to CON2-1 and black lead to and CON1-1 on the control board. Plug in dishwasher or reconnect power.
10. Start the Service Mode Test and at step-5 measure for AC out of the control between CON2-1 and CON1-1.
 

**IMPORTANT:** The Drain Motor must be connected to the control board to measure voltage accurately!

  - If no AC voltage is measured, replace the control board and retest.
  - If 120 VAC is measured and drain pump is running, go to step 11.
11. Unplug dishwasher or disconnect power.
12. Reassemble all parts and panels.
13. Plug in dishwasher or reconnect power and run Service Mode to verify repair.

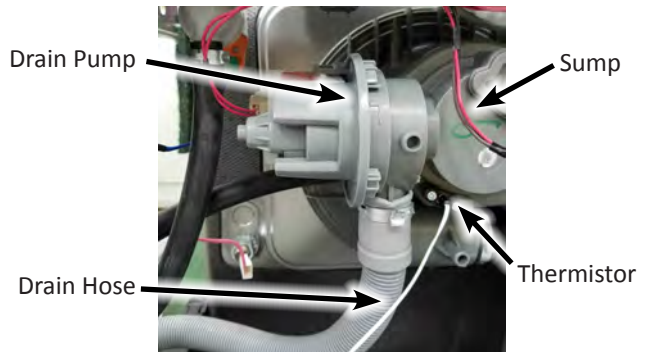

Figure 1 - Drain Pump

#### STRIP CIRCUIT - DRAIN PUMP

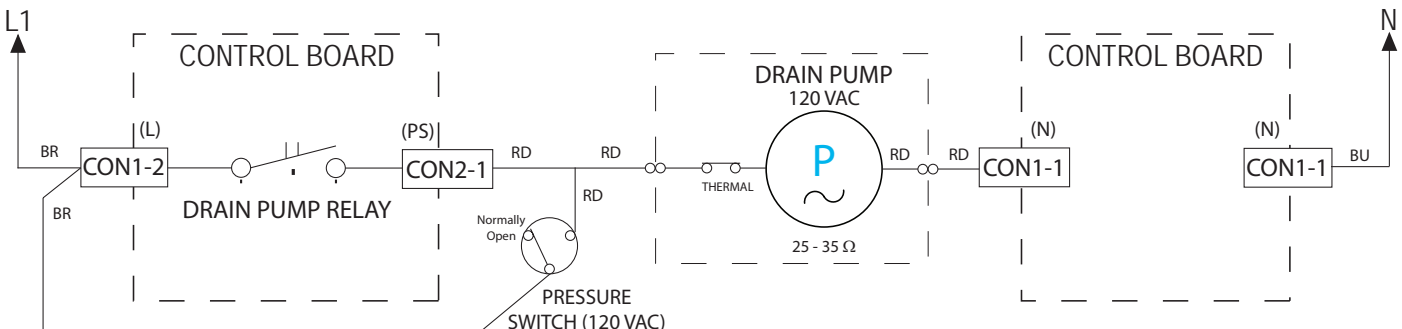



Figure 2 - Drain Pump Strip Circuit



## For Service Technician Use Only

**⚠ WARNING**



**Electrical Shock Hazard**

**Disconnect power before servicing.**

**Replace all parts and panels before operating.**

**Failure to do so can result in death or electrical shock.**

### Pressure Switch

The pressure switch is an overfill safety device mounted on the base located on the right front. A clear plastic tube (the pressure switch hose) runs from the switch to the sump.

As the dishwasher tub fills with water, the air pressure in the pressure switch hose increases. Normally, the control board regulates the amount of time the water fill valve remains open. If the water fill valve remains energized, the overfilling of the tub increases the air pressure in the pressure hose causing the pressure switch to close and energize the drain pump.

This test will check the wiring to the pressure switch and the pressure switch itself. The following items are part of the pressure switch circuit.

- Harness/Connection
- Pressure Switch
- Pressure Switch Hose

### Test Procedure

1. Unplug dishwasher or disconnect power.
2. Remove access panel. Remove control board cover to access control board.
3. Lay the dishwasher on its back. Use a small flat-blade screwdriver to unclip snaps around the drip-pan. Remove drip-pan/float switch to access under tub components.
4. Check hose connections between the pressure switch and sump. Ensure hose is routed correctly and not pinched or crimped.
5. Verify there is no debris in the hose. Check hose for leaks. Repair or replace as needed.
6. Check the following harnesses for continuity (refer to the following chart).

Pressure Switch Continuity Check
Pressure Switch to CON1-2 (Brown Wire)
Pressure Switch to CON2-1 (Red Wire)
Pressure Switch to Drain Pump (Red Wire)

- If an open circuit is detected, check connections between control board, pressure switch, and drain pump. Repair or replace as necessary.
  - If all harness test good, proceed to step 7.
7. Check the pressure switch. Using an ohmmeter, measure the resistance across the pressure switch terminals (refer to the following chart).

Pressure Switch Continuity Check	
No Pressure	Switch Open - Infinite or High Resistance
Apply Pressure (Blow into hose*)	Switch Closed - Continuity (less than 3 ohms)

\* When you blow into the pressure hose that is connected to the switch, an audible “click” can be heard indicating the switch has closed.

- If all pressure switch checks pass, continue to step 8.
  - If the preceding checks did not pass, replace the Pressure Switch.
8. Reassemble all parts and panels.
  9. Plug in dishwasher or reconnect power and retest.

### STRIP CIRCUIT - PRESSURE SWITCH

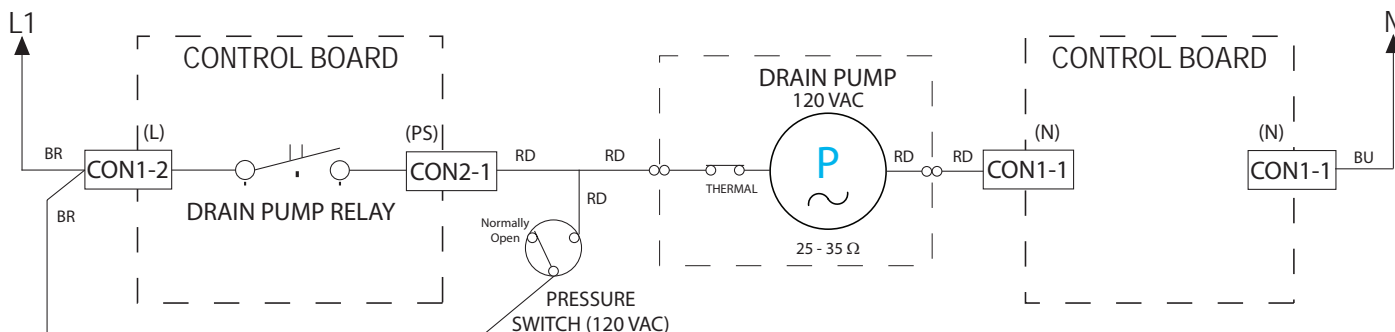

Figure 2 - Pressure Switch Strip Circuit

## **Notes**

## Section 4: Component Access

This section provides service parts access, removal, and installation instructions for the 18" & 24" ADA Built-In Dishwashers.

- Removing the Tub Gasket and Trim
- Removing the Outer Door Panel
- Removing the Control Panel
- Removing Door Switch Assembly
- Removing Dispenser Assembly
- Removing the Inner Door Panel
- Removing the Air Breaker Assembly
- Removing the Nozzle Duct
- Removing the Control Board
- Removing the Water Valve
- Under Tub Components
- Removing the Pressure Switch
- Removing the Drain Pump
- Removing the Thermistor & Turbidity Sensor
- Removing the Heater Element
- Removing the Wash Pump Assembly
- Removing the Sump Assembly

## Removing the Tub Gasket and Trim

### Remove the Tub Gasket and Trim

The dishwasher tub seal prevents water leakage. The seal is fitted in a seal channel that lines the rim of the dishwasher tub.

**To remove the tub seal or trim:**

1. Open the dishwasher door.
2. Remove the dishwasher tub seal by grasping one end of the seal to peel it away from the seal channel (see Figure 1).



*Figure 1*

3. Remove the 2 screws (as indicated in Figure 2) and then pull the trim straight off the lip of the tub.



*Figure 2*

4. Reverse the above procedures to reinstall.

**NOTE:** When installing the tub seal, make sure it is seated properly in the seal channel. Run your finger over the seal to make sure it is smooth and even for a proper seal. A correctly installed gasket will have both ends of the gasket equally distant from the bottom of the tub.

## Removing the Outer Door Panel

### **⚠ WARNING**



**Electrical Shock Hazard**  
Disconnect power before servicing.  
Replace all parts and panels before operating.  
Failure to do so can result in death or electrical shock.

### Remove Outer Door Panel

1. Unplug dishwasher or disconnect power.
2. Remove six (6) screws on the sides and top of door panel assembly (see Figure 1).

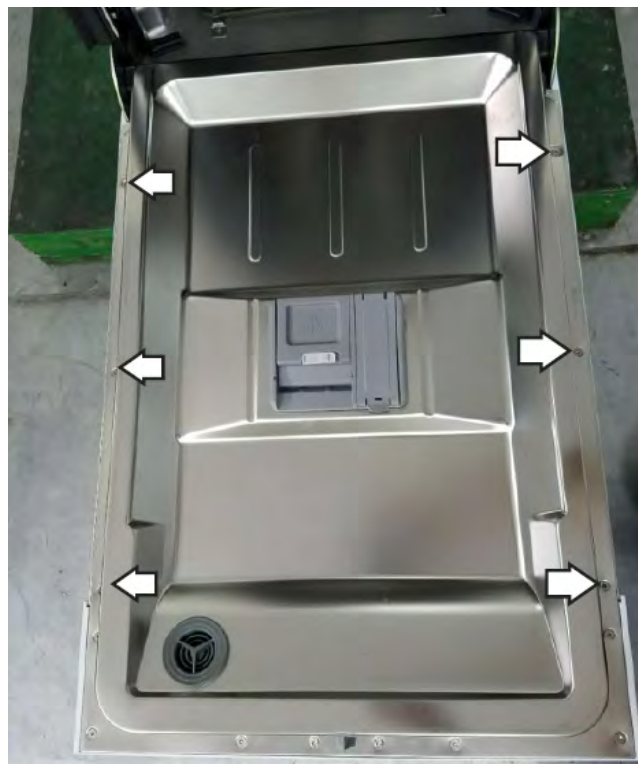

*Figure 1*

3. Then, lower the outer door panel from the control panel and remove (see Figure 2).



*Figure 2*

## Removing the Control Panel

### **⚠ WARNING**



**Electrical Shock Hazard**  
Disconnect power before servicing.  
Replace all parts and panels before operating.  
Failure to do so can result in death or electrical shock.

### Removing the Control Panel

1. Unplug dishwasher or disconnect power.
2. Perform the procedures on page 4-2, "Remove Outer Door Panel" prior to performing the following steps.
3. Remove the eight (8) screws indicated in Figure 1.



Figure 1

4. Disconnect the User Interface harness and remove the handle cover. See Figure 2.
5. Remove the two (2) screws (indicated in Figure 2) to remove the User Interface PCBA.

Disconnect UI Harness



Figure 2



## Removing Door Switch Assembly

### **⚠ WARNING**



**Electrical Shock Hazard**  
 Disconnect power before servicing.  
 Replace all parts and panels before operating.  
 Failure to do so can result in death or electrical shock.

### Remove Door Switch Assembly

1. Unplug dishwasher or disconnect power.
2. Disconnect the 2-pin harness from the door switch assembly on top of the dishwasher (see Figure 1).



*Figure 1*

3. Using a Phillips screwdriver, remove the two (2) screws securing the door switch assembly to the cabinet. See Figure 2.

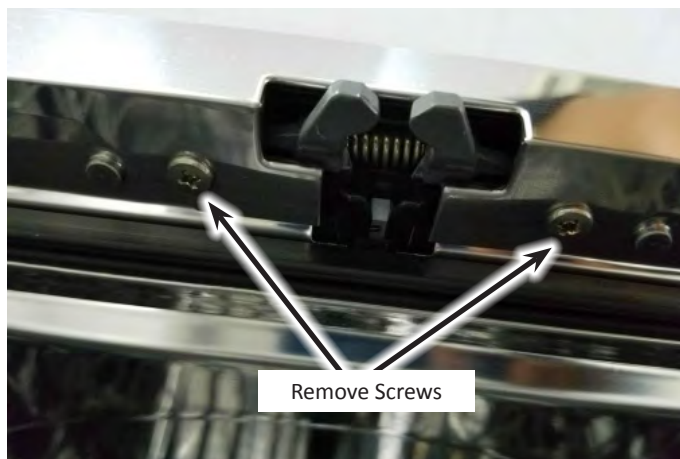

*Figure 2*

4. Remove door switch assembly.

## Removing Dispenser Assembly

### **⚠ WARNING**



**Electrical Shock Hazard**  
Disconnect power before servicing.  
Replace all parts and panels before operating.  
Failure to do so can result in death or electrical shock.

### Remove Dispenser Assembly

1. Unplug dishwasher or disconnect power.
2. Perform the procedures on page 4-2, "Remove Outer Door Panel" prior to performing the following steps.
3. Disconnect both dispenser harnesses (see Figure 1).



Figure 1

4. To remove the dispenser assembly, use a flat-blade screwdriver to move out the ten (10) snap clips, then push in to disengage from bracket. See Figure 2.



Figure 2

5. To reinstall the dispenser, press in the ten (10) snap clips inward as shown in Figure 3.



Figure 3

6. Press detergent dispenser inward into the bracket, ensuring all snap clips engage the assembly (see Figure 4).



Figure 4



## Replacing the Inner Door Panel

**⚠ WARNING**



**Electrical Shock Hazard**

**Disconnect power before servicing.**

**Replace all parts and panels before operating.**

**Failure to do so can result in death or electrical shock.**

### Replace Inner Door Panel

1. Unplug dishwasher or disconnect power.
2. Perform the procedures on page 4-3, "Remove the Control Panel" prior to performing the following steps.
3. Perform the procedures on page 4-5, "Remove the Dispenser Assembly" prior to performing the following steps.
4. Remove the two (2) screws from the hinge plate (as indicated in Figure 1).



Figure 1

5. Remove the two (2) screws from the base side panel on each side (indicated in Figure 2).



Figure 2

6. Disconnect door spring and door cable (see Figure 3).

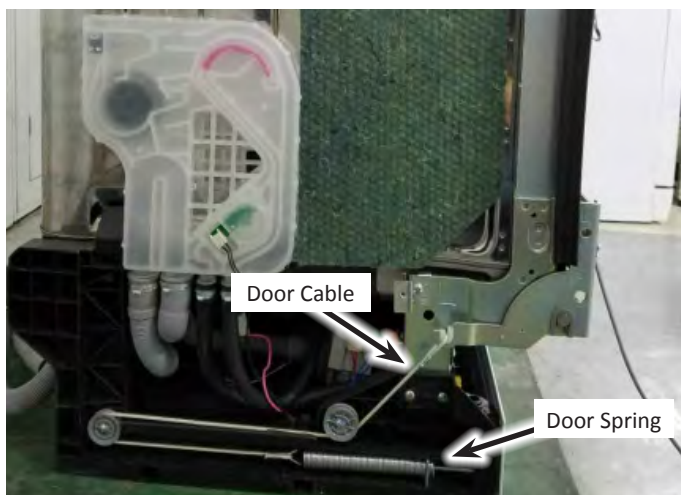

Figure 3

7. Open the inner door approximately 10° and lift the door until the door hinge separates from the pin. See Figure 4.

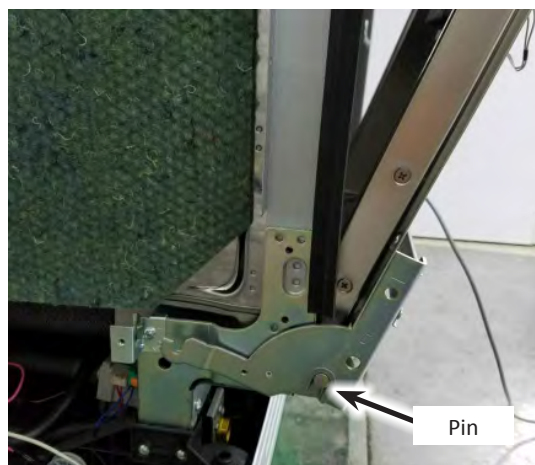

Figure 4

## Removing the Air Breaker Assembly

### **⚠ WARNING**



**Electrical Shock Hazard**  
**Disconnect power before servicing.**  
**Replace all parts and panels before operating.**  
**Failure to do so can result in death or electrical shock.**

### Remove the Air Breaker Assembly

The Air breaker assembly is mounted on the left side of the tub. Its purpose is to provide a method of supplying water for the wash and rinse cycles. The air gap prevents the siphoning of wash water from flowing back into the water supply system and prevents the water pressure from not dropping below atmospheric pressure.

The Air breaker assembly also allows air into the tub for improved drying.

#### To remove the air breaker assembly:

1. Unplug dishwasher or disconnect power.
2. Remove the base side panel.
3. Disconnect flow meter harness from the air breaker assembly (see Figure 1).



Figure 1

4. Open the door and from inside the cabinet, rotate the air breaker nut and remove it from the air breaker assembly.
5. Pull away the air breaker assembly and remove the four (4) clamps securing the hoses to the assembly. See Figure 2.



Figure 2



## Removing the Nozzle Duct

### **⚠ WARNING**



**Electrical Shock Hazard**  
 Disconnect power before servicing.  
 Replace all parts and panels before operating.  
 Failure to do so can result in death or electrical shock.

3. Release the snap clips (left side shown in the Figure 2). Then remove the nozzle duct and lower spray seat.

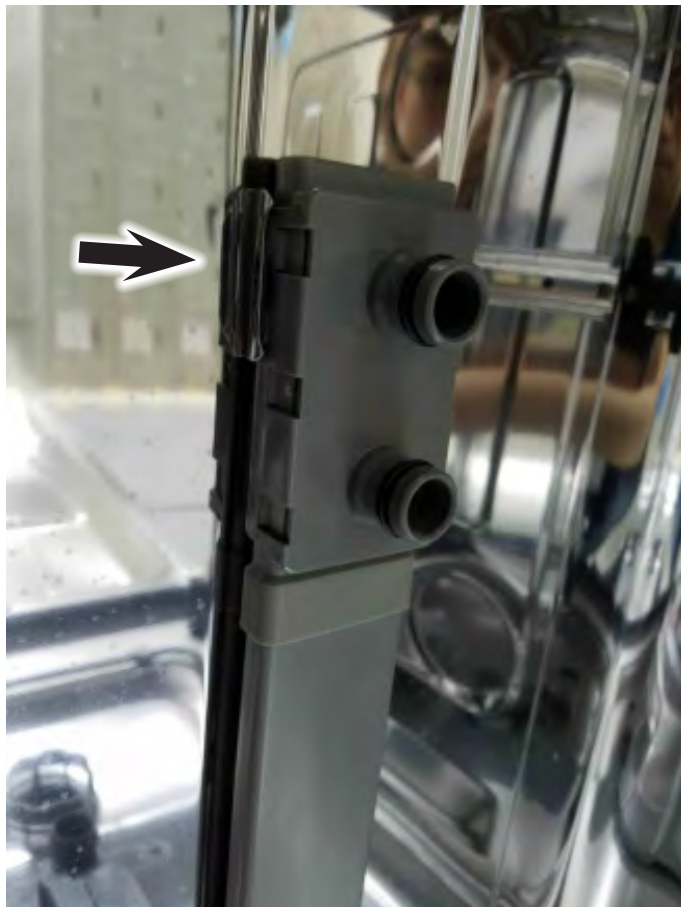

Figure 2

### Remove the Nozzle Duct

1. Unplug dishwasher or disconnect power.
2. Open the door, and remove the 2 screws on the Lower spray seat (see Figure 1).



Figure 1

## Removing the Control Board

**⚠ WARNING**



**Electrical Shock Hazard**  
Disconnect power before servicing.  
Replace all parts and panels before operating.  
Failure to do so can result in death or electrical shock.

### Remove the Control Board

The Control Board can be removed from its enclosure at the bottom of the dishwasher.

1. Unplug dishwasher or disconnect power.
2. Remove two (2) screws securing the kick board (toe panel) to dishwasher frame (see Figure 1).

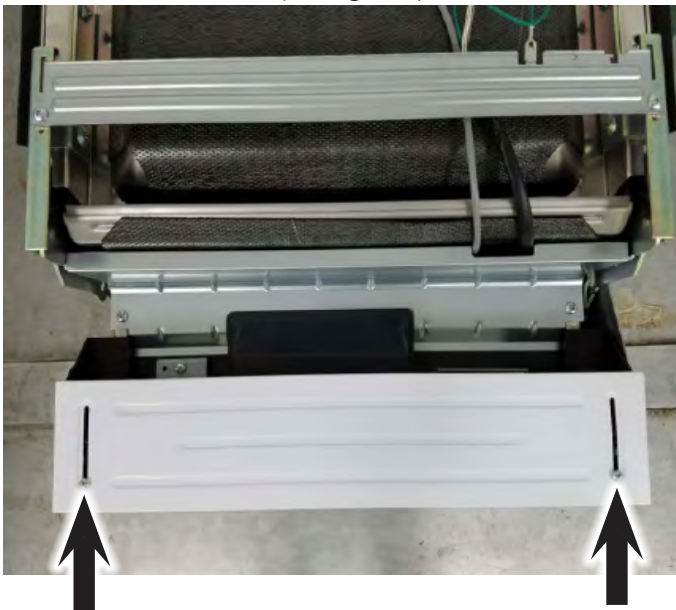

Figure 1

3. Remove one (1) cover screw from the control board enclosure (see Figure 2). Remove cover and set aside.



Figure 2

4. Disconnect all harnesses from the control board.
5. Depress the two (2) clips indicated in Figure 3 and remove control board from enclosure.

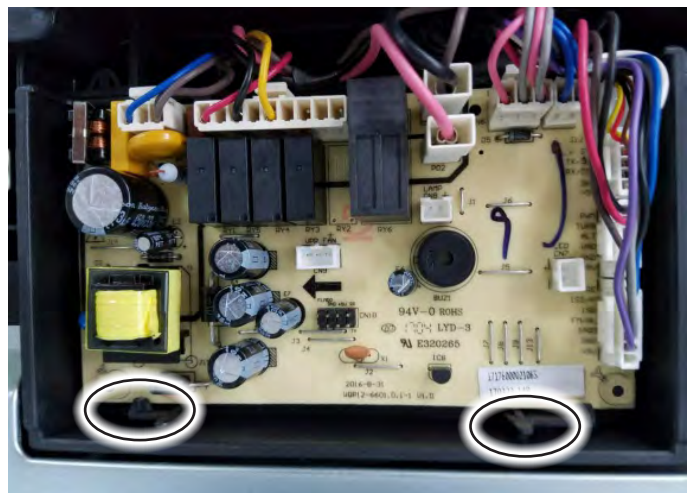



Figure 3

## Removing the Water Valve

<b>⚠ WARNING</b>

<p style="text-align: center;"><b>Electrical Shock Hazard</b></p> <p><b>Disconnect power before servicing.</b></p> <p><b>Replace all parts and panels before operating.</b></p> <p><b>Failure to do so can result in death or electrical shock.</b></p>

### Remove the Water Valve

The water valve is mounted on a bracket located on the left side of the front brace.

1. Unplug dishwasher or disconnect power.
2. Remove the two (2) screws on the kick board (toe panel). See Figure 1.
3. Remove the two (2) screws on insulating panel (see Figure 1).

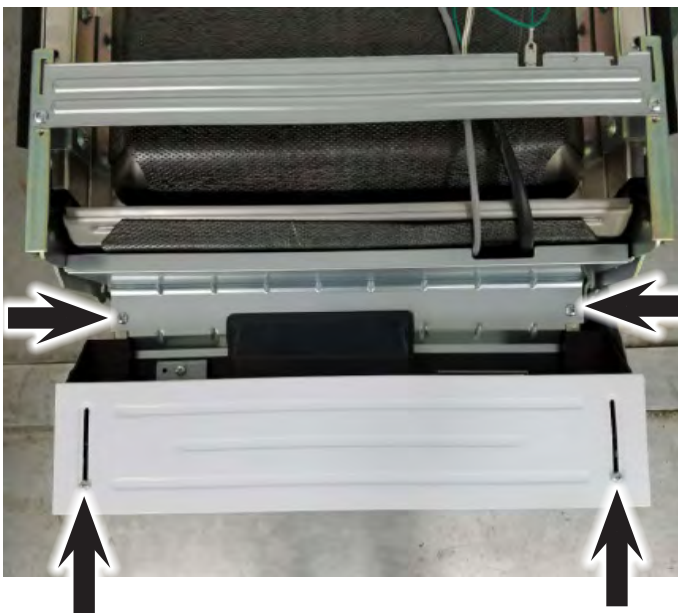

Figure 1

4. Remove the 2 screws that hold the water valve to the front brace (see Figure 2).
5. Remove the fixing flat just like the picture below.



Figure 2

6. Disconnect the wire from the solenoid (see Figure 3).
7. Remove the clamp and the outlet hose from the water valve (see Figure 3).

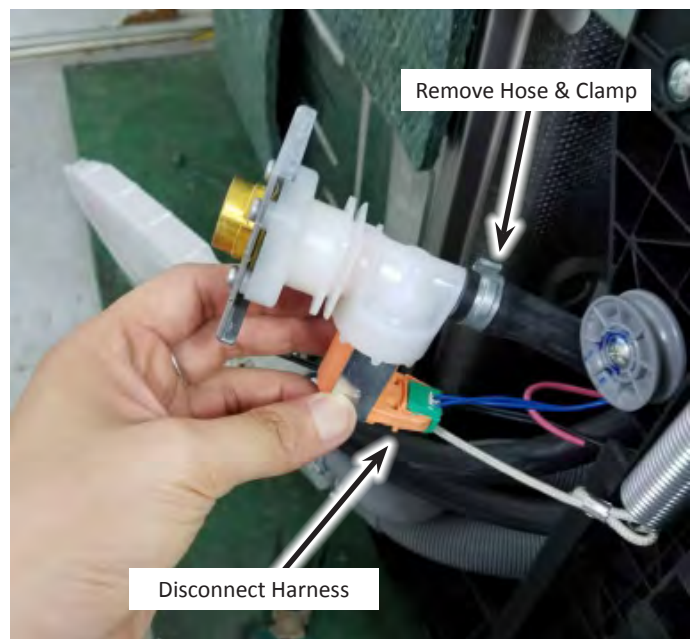
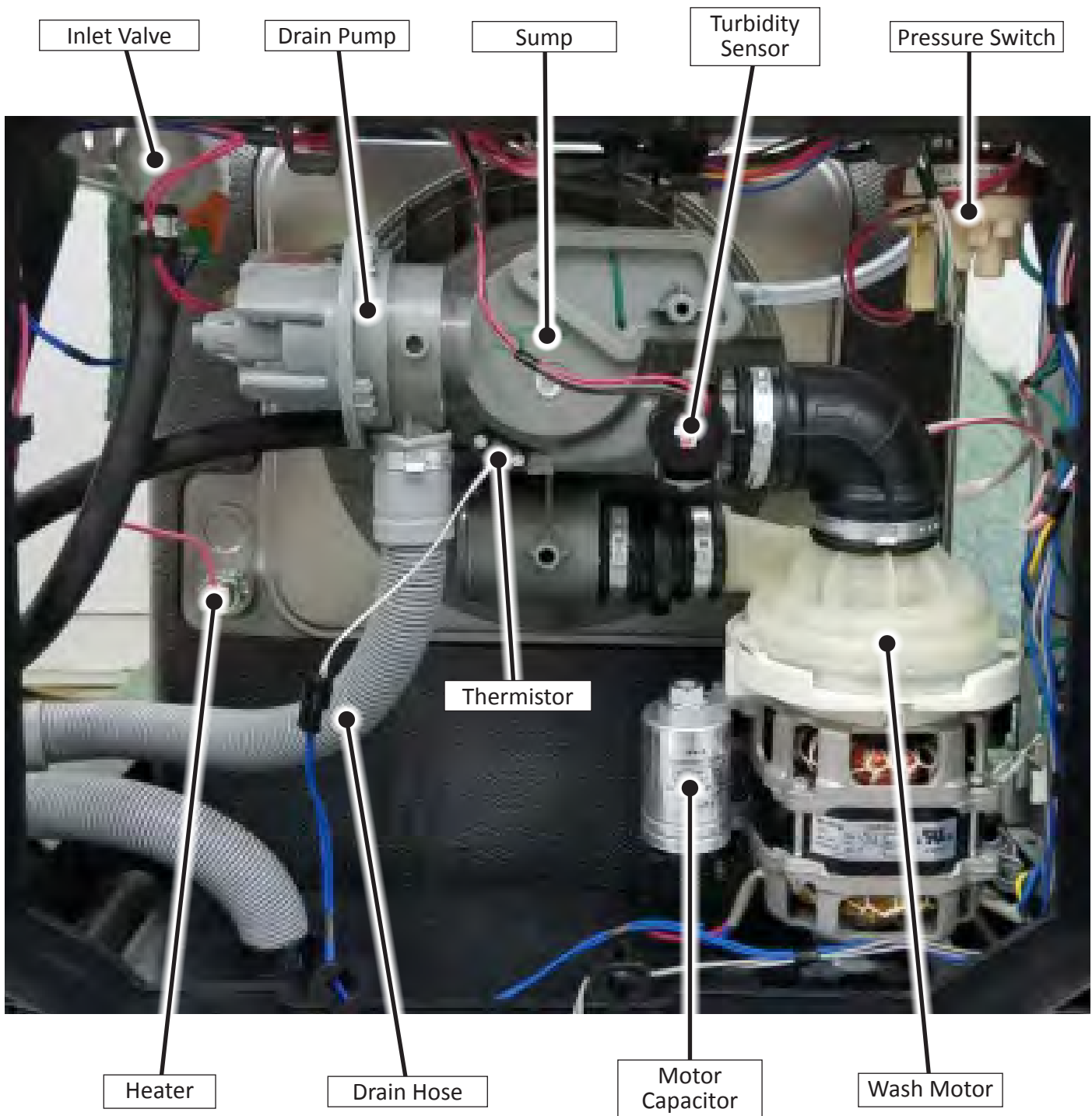

Figure 3

**IMPORTANT:** The clamp is easily damaged during removal and should not be reused. Use the screw-type hose clamp provided with the new valve.



## Under Tub Components



Under Tub Component Identification

## Removing the Pressure Switch

### **WARNING**



**Electrical Shock Hazard**  
 Disconnect power before servicing.  
 Replace all parts and panels before operating.  
 Failure to do so can result in death or electrical shock.

### Remove the Pressure Switch

1. Unplug dishwasher or disconnect power.
2. Open the dishwasher door and take out cutlery basket and lower rack.
3. Remove dishwasher from installation and lay dishwasher on its back.
4. Remove the one (1) screw that attaches base cover to the base. Remove base cover and set aside.
5. Release the snap clip that attaches the pressure switch to the base. Remove pressure switch from dishwasher.

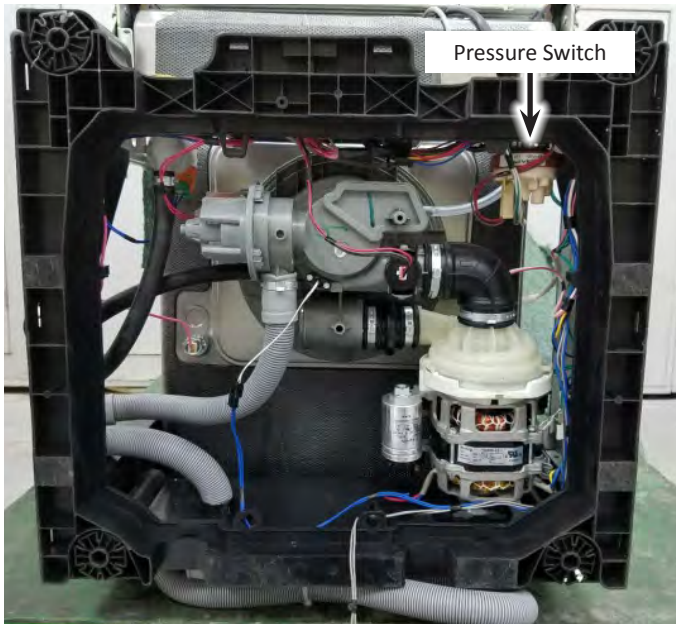

Figure 1

6. Disconnect harness from pressure switch (see Figure 2).
7. Remove the pressure switch hose from the pressure switch. See Figure 2.

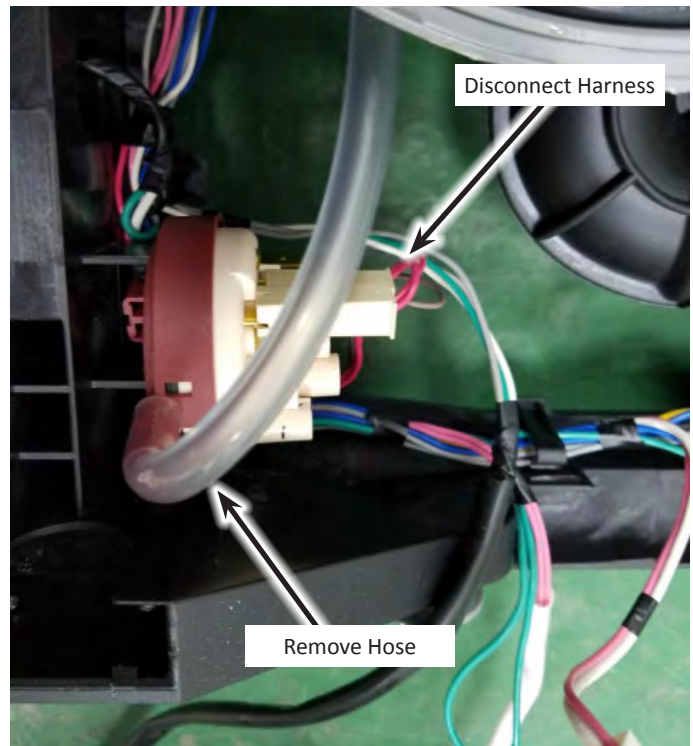

Figure 2

**NOTE:** When installing the pressure switch, ensure the switch is fully seated in the bottom of the base bracket.



## Removing the Drain Pump

### **⚠ WARNING**



**Electrical Shock Hazard**  
Disconnect power before servicing.  
Replace all parts and panels before operating.  
Failure to do so can result in death or electrical shock.

### Remove the Drain Pump

1. Unplug dishwasher or disconnect power.
2. Open the dishwasher door and take out cutlery basket and lower rack.
3. Remove dishwasher from installation and lay dishwasher on its back.
4. Remove the one (1) screw that attaches base cover to the base. Remove base cover and set aside.

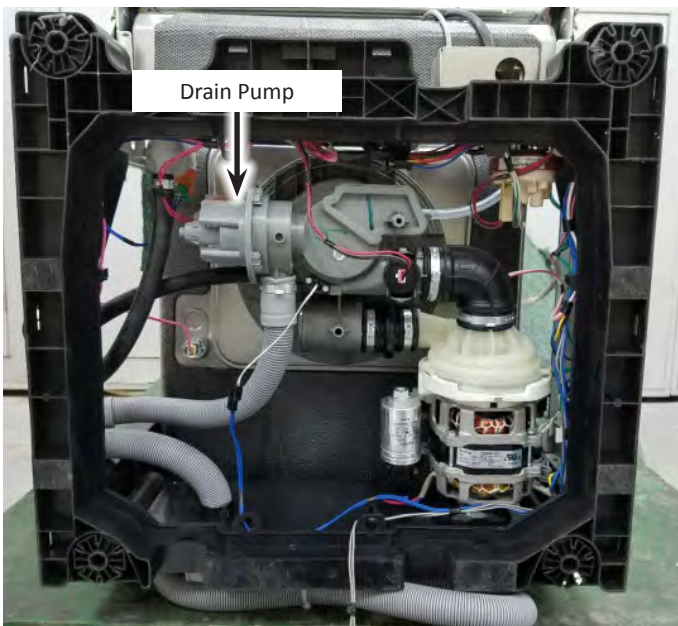

Figure 1

6. Disconnect wire harness from drain pump.
5. Grasp drain pump and rotate 1/4 turn counterclockwise to remove (which the opposite direction of the mark on the sump). See Figure 2.

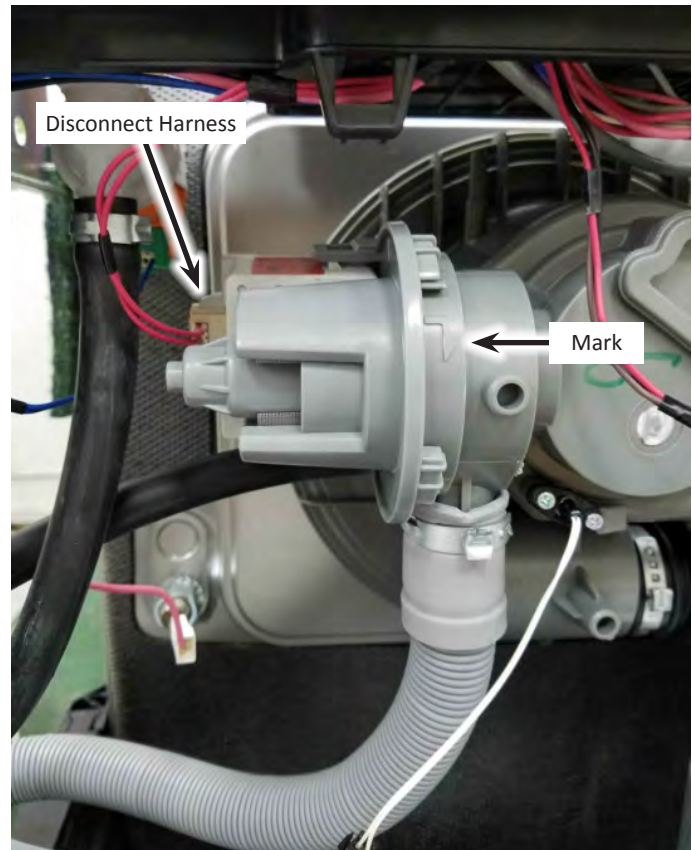

Figure 1

**NOTE:** Ensure the “O” Ring is retained in the drain pump before reassembly.

## Removing the Thermistor & Turbidity Sensor

### ⚠ WARNING



**Electrical Shock Hazard**  
**Disconnect power before servicing.**  
**Replace all parts and panels before operating.**  
**Failure to do so can result in death or electrical shock.**

### Remove the Turbidity Switch

1. Unplug dishwasher or disconnect power.
2. Open the dishwasher door and take out cutlery basket and lower rack.
3. Remove dishwasher from installation and lay dishwasher on its back.
4. Remove the one (1) screw that attaches base cover to the base. Remove base cover and set aside.
5. Disconnect the turbidity sensor wire harness (see Figure 1).
5. Release the snap clips to remove the turbidity sensor from the dishwasher.

### Remove the Thermistor

1. Unplug dishwasher or disconnect power.
2. Open the dishwasher door and take out cutlery basket and lower rack.
3. Remove dishwasher from installation and lay dishwasher on its back.
4. Remove the one (1) screw that attaches base cover to the base. Remove base cover and set aside.
5. Disconnect the thermistor wire harness (see Figure 1).
6. Using screwdriver remove the two (2) screws securing thermistor to the sump (see Figure 1). Remove thermistor.

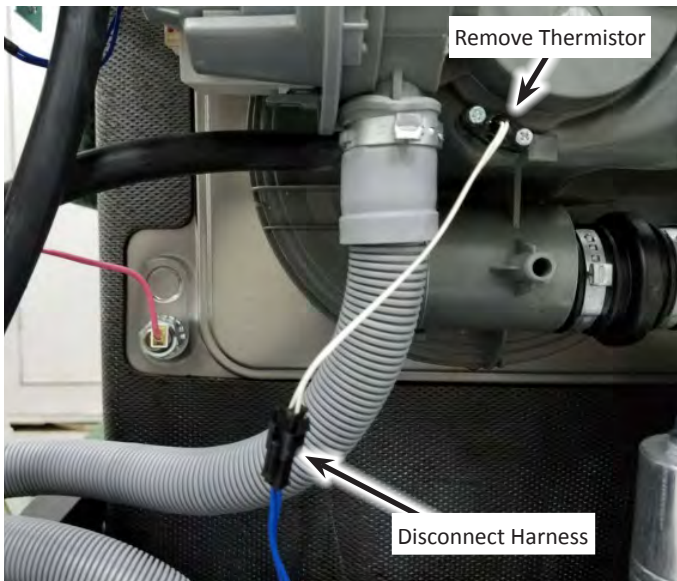

Figure 1

**NOTE:** Ensure the "O" Ring is retained in the Thermistor before reassembly.

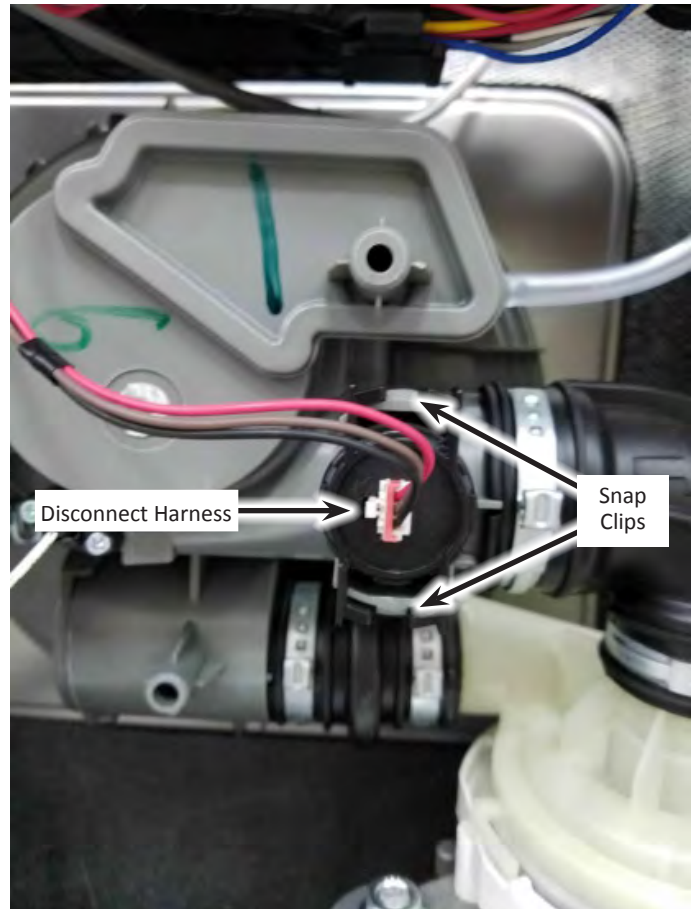

Figure 1

**NOTE:** Ensure the "O" Ring is retained in the turbidity sensor before reassembly.



## Removing the Heating Element

### **⚠ WARNING**



**Electrical Shock Hazard**  
Disconnect power before servicing.  
Replace all parts and panels before operating.  
Failure to do so can result in death or electrical shock.

### Remove the Heating Element

1. Unplug dishwasher or disconnect power.
2. Open the dishwasher door and take out cutlery basket and lower rack.
3. Remove dishwasher from installation and lay dishwasher on its back.
4. Remove the one (1) screw that attaches base cover to the base. Remove base cover and set aside.
5. Disconnect the two (2) pink wires from the heating element terminals (see Figure 1).

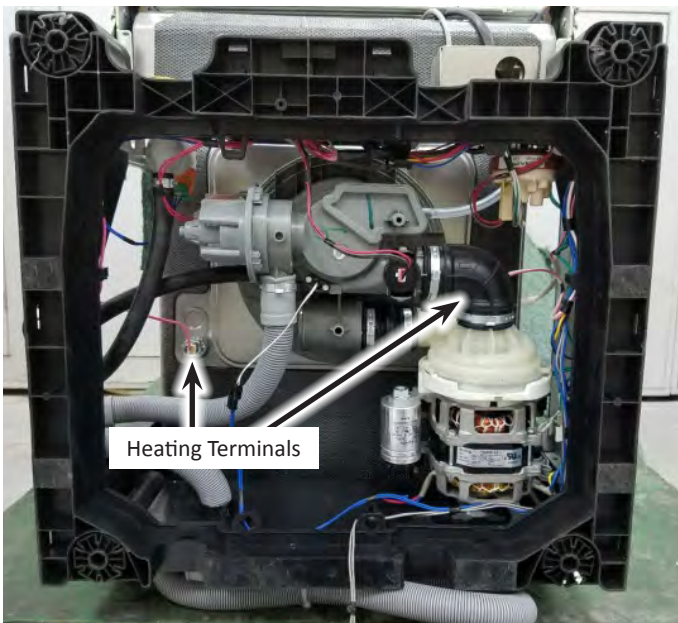

Figure 1

6. Remove the nuts and washers that attach the heating element to the bottom of the tub (see Figure 2).  
**NOTE:** Sump is removed to show location of heater terminals, nuts and washers.



Figure 2

7. From the inside of the tub, lift the backside of the element and release it from the 2 retainers. See Figure 3.



Figure 3

## Removing the Wash Pump Assembly

### WARNING



**Electrical Shock Hazard**  
 Disconnect power before servicing.  
 Replace all parts and panels before operating.  
 Failure to do so can result in death or electrical shock.

**NOTE:** Factory-installed hose clamps are not reusable. When installing a water inlet valve, drain pump assembly, wash pump assembly, or sump assembly, replace the old clamps with new screw-type hose clamps provided. The screw-type hose clamps are available separately.

7. Disconnect the wash pump harness, pump ground wire, and rubber support.

### Remove the Wash Pump Assembly

1. Unplug dishwasher or disconnect power.
2. Open the dishwasher door and take out cutlery basket and lower rack.
3. Remove dishwasher from installation and lay dishwasher on its back.
4. Remove the one (1) screw that attaches base cover to the base. Remove base cover and set aside.
5. Remove wash pump outlet clamps and hose (see Figure 1).
6. Remove wash pump inlet clamps and hose (see Figure 1).

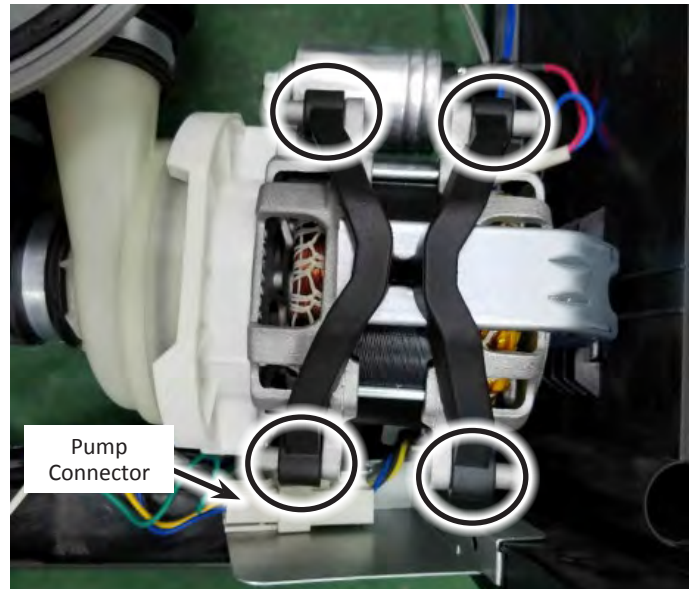

Figure 2

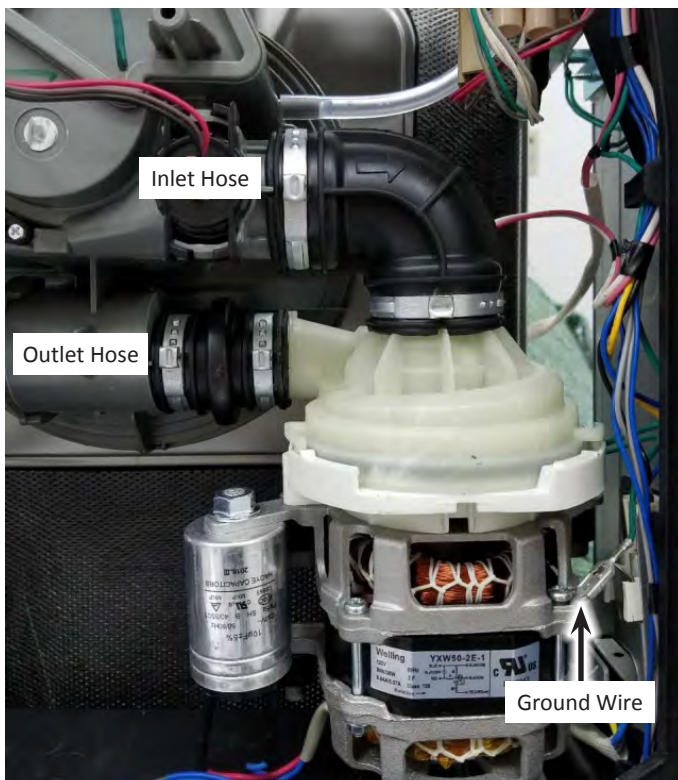

Figure 1

### To Remove the Wash Pump Capacitor:

1. Follow steps 1 through 7.
2. The capacitor is connected to the pump with 2 wires and held in place with a nut. Disconnect the wires and the nut (see Figure 3).

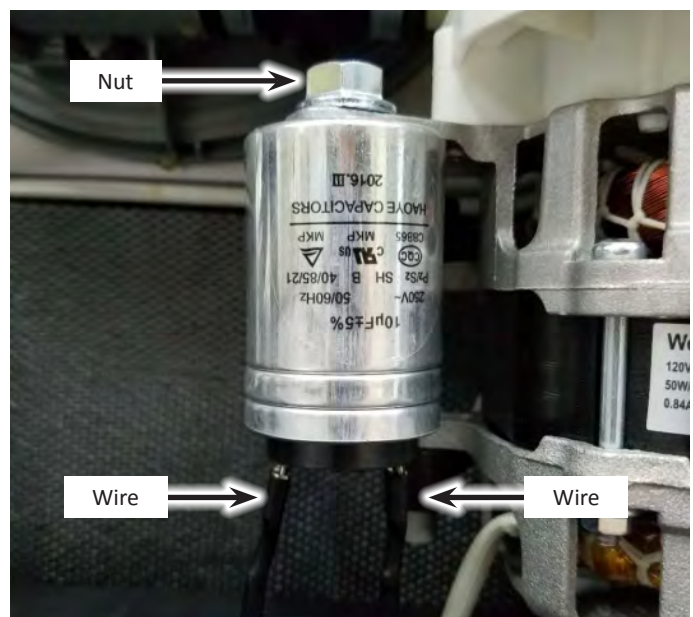

Figure 3



## Removing the Sump Assembly

### **⚠ WARNING**



**Electrical Shock Hazard**  
**Disconnect power before servicing.**  
**Replace all parts and panels before operating.**  
**Failure to do so can result in death or electrical shock.**

### Removing the Sump Assembly

#### Preparation:

Remove the following items from inside the dishwasher (see Figure 1 below):

1. Cutlery Basket (not shown)
2. Lower Rack (not shown)
3. Lower Spray Arm
4. Cylindrical Filter (1/4 turn counterclockwise)
5. Steel Filter (lift out)
6. Lower Spray Seat (see page 4-9)

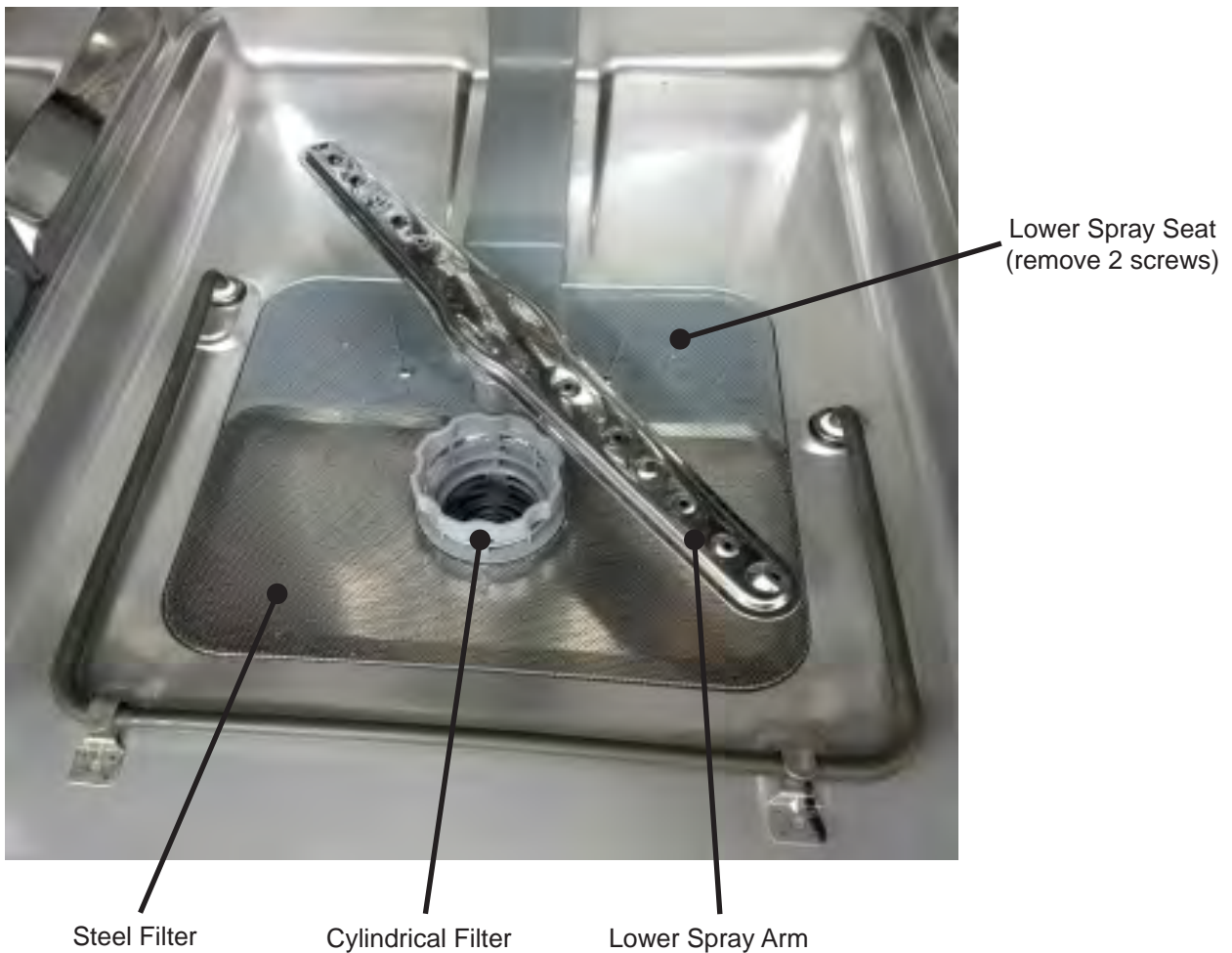

Figure 1

Continued on next page . . .

## Removing the Sump Assembly (continued)

- Remove the three (3) screws that attach the sump to the tub. See Figure 2.

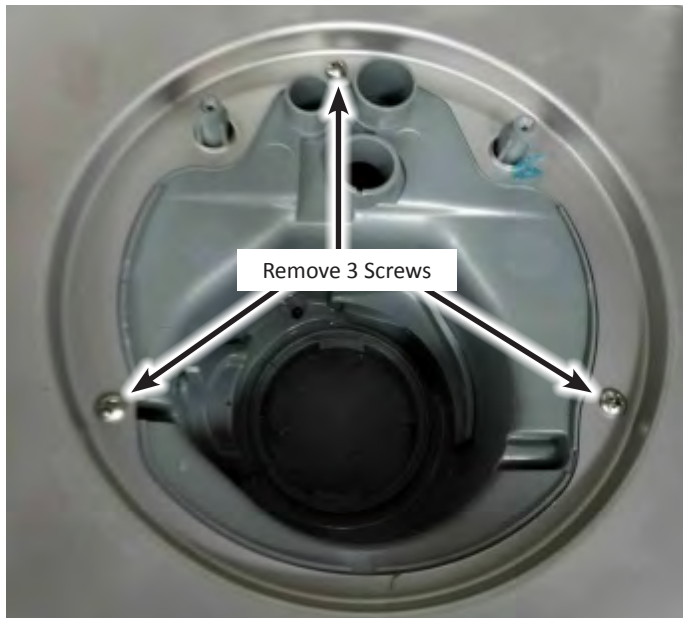

Figure 2

- Remove the sump gasket (not shown) and sump.
- Remove dishwasher from installation and lay dishwasher on its back.
- Disconnect the thermistor wire harness and turbidity sensor wire harness. See Figure 3.

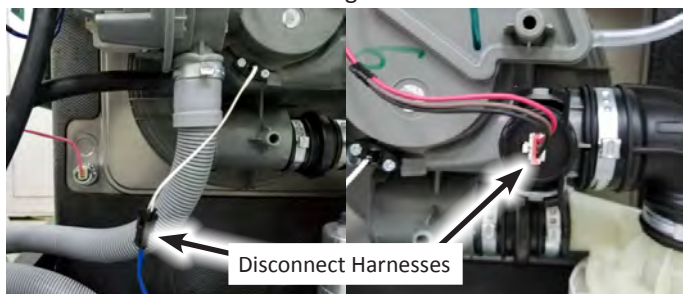

Figure 3

- Remove the 2 clamps, sump outlet hose, and inlet hose from the sump. See Figure 4.

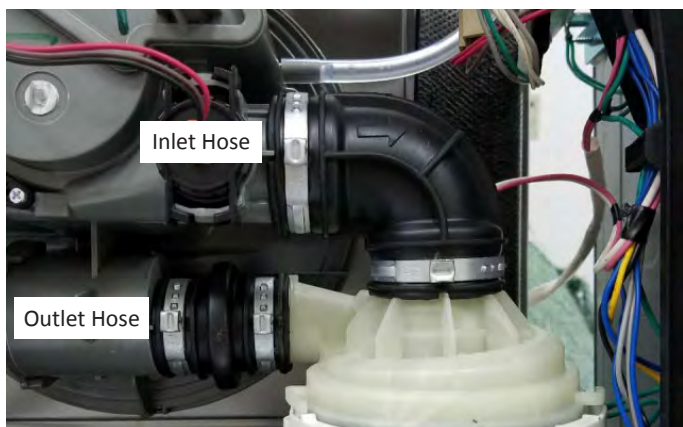

Figure 4

**NOTE:** Factory installed hose clamps are not reusable. When installing a water inlet valve, drain pump assembly, wash pump assembly, or sump assembly, replace the old clamps with new screw-type hose clamps provided. The screw-type hose clamps are available separately.

- Remove the drain pump from the sump.
- Remove the inner drain hose from the sump.

### Sump - Top View



Figure 5

### Sump - Bottom View

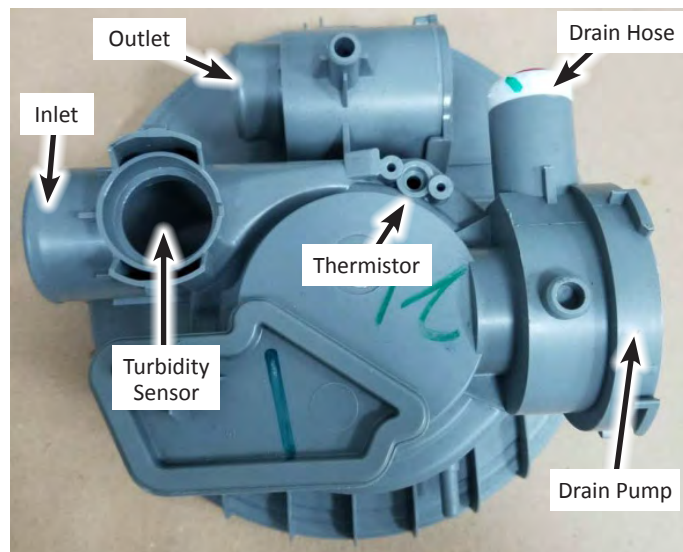

Figure 6

# Notes



# PRODUCT SPECIFICATIONS & WARRANTY INFORMATION SOURCES

---

## ***IN THE UNITED STATES:***

**FOR PRODUCT SPECIFICATIONS AND WARRANTY INFORMATION CALL:  
FOR WHIRLPOOL PRODUCTS: 1-800-253-1301**

**FOR TECHNICAL ASSISTANCE WHILE AT THE CUSTOMER'S HOME CALL:  
THE TECHNICAL ASSISTANCE LINE: 1-800-832-7174**

**HAVE YOUR STORE NUMBER READY TO IDENTIFY YOU AS AN  
AUTHORIZED IN-HOME SERVICE PROFESSIONAL**

**FOR LITERATURE ORDERS (CUSTOMER EXPERIENCE CENTER):  
PHONE: 1-800-851-4605**

**FOR TECHNICAL INFORMATION AND SERVICE POINTERS:  
[www.servicematters.com](http://www.servicematters.com)**

---

## ***IN CANADA:***

**FOR PRODUCT SPECIFICATIONS AND WARRANTY INFORMATION CALL  
1-800-461-5681**

**FOR TECHNICAL ASSISTANCE WHILE AT THE CUSTOMER'S HOME CALL:  
THE TECHNICAL ASSISTANCE LINE: 1-800-488-4791**

**HAVE YOUR STORE NUMBER READY TO IDENTIFY YOU AS AN  
AUTHORIZED IN-HOME SERVICE PROFESSIONAL**

**18" & 24" ADA Models  
Built-In Dishwashers**

**W11187658**