



MC11H6033CT

Microwave Oven

Owner's Instructions & Cooking Guide

imagine the possibilities

Thank you for purchasing this Samsung product.

SAMSUNG

contents

safety information	2
quick look-up guide	10
oven features	11
Oven.....	11
Control panel.....	11
Accessories.....	12
oven use	12
How a microwave oven works	12
Checking if your oven is operating correctly	13
Setting the time	13
Cooking/Reheating	14
Power levels and time variations	14
Adjusting the cooking time.....	14
Stopping the cooking.....	15
Setting the energy save mode.....	15
Using the popcorn feature	15
Using the defrost features	16
Using the auto reheat/cook features	17
Using the slim fry cook features	18
Multistage cooking.....	20
Fast preheating the oven.....	21
Cooking by convection	21
Choosing the proper cookware.....	22
Grilling	22
Combining microwave cooking and the grill	22
Combining microwave cooking and convection	23
Turning the beeper off.....	24
Safety-locking your microwave oven	24
cookware guide	24
Microwave-safe utensils.....	24
cooking guide	26
troubleshooting and error codes	35
Troubleshooting	35
Error code	36
Warranty and service information	36
technical specifications	37
warranty	37
Samsung microwave oven.....	37

safety information

Congratulations on your new Samsung microwave oven. This manual contains important information on the installation, use and care of your appliance. Please take time to read this manual to take full advantage of your microwave oven's many benefits and features.

WHAT YOU NEED TO KNOW ABOUT SAFETY INSTRUCTIONS

Warnings and Important Safety Instructions in this manual do not cover all possible conditions and situations that may occur. It is your responsibility to use common sense, caution, and care when installing, maintaining, and operating your microwave oven.

PRECAUTIONS TO AVOID POSSIBLE EXPOSURE TO EXCESSIVE MICROWAVE ENERGY

- A.** Do not attempt to operate this oven with the door open since open-door operation can result in harmful exposure to microwave energy. It is important not to defeat or tamper with the safety interlocks.
- B.** Do not place any object between the oven front face and the door or allow soil or cleaner residue to accumulate on the sealing surface.
- C.** Do not operate the oven if it is damaged. It is particularly important that the oven door close properly and that there is no damage to the:
 - 1.** Door (bent),
 - 2.** Hinges and latches, (broken or loosened),
 - 3.** Door seals and sealing surface.
- D.** The oven should not be adjusted or repaired by anyone except properly qualified service personnel.

SAVE THESE INSTRUCTIONS

IMPORTANT SAFETY SYMBOLS AND PRECAUTIONS

What the icons and signs in this user manual mean:

 **WARNING** Hazards or unsafe practices that may result in **severe personal injury or death.**

 **CAUTION** Hazards Hazards or unsafe practices that may result in **minor personal injury or property damage.**

 **CAUTION** To reduce the risk of fire, explosion, electric shock, or personal injury when using your microwave oven, follow these basic safety precautions.

 Do NOT attempt.

 Unplug the power plug from the wall socket.

 Do NOT disassemble.

 Make sure the machine is grounded to prevent electric shock.

 Do NOT touch.

 Call the service center for help.

 Follow directions explicitly.

 Note

These warning signs are here to prevent injury to you and others. Please follow them explicitly. After reading this section, keep it in a safe place for future reference.

STATE OF CALIFORNIA PROPOSITION 65 WARNING (US ONLY)

WARNING : This product contains chemicals known to the State of California to cause cancer and birth defects or other reproductive harm.

SAVE THESE INSTRUCTIONS

IMPORTANT SAFETY INSTRUCTIONS

When using any electrical appliance, basic safety precautions should be followed, including the following:

WARNING

To reduce risk of burns, electric shock, fire, personal injury or exposure to excessive microwave energy:

1. Read all safety instructions before using the appliance.
2. Read and follow the specific "Precautions to avoid possible exposure to excessive microwave energy" on page 2.
3. This appliance must be grounded. Connect only to properly grounded outlets. See Important "Grounding instructions" on page 4 of this manual.
4. Install or locate this appliance only in accordance with the provided installation instructions.
5. Some products such as whole eggs and sealed containers (for example, closed glass jars) can explode if heated rapidly. Never heat them in a microwave oven.
6. Use this appliance only for its intended use as described in the manual. Do not put corrosive chemicals or vapors in or on this appliance. This type of oven is specifically designed to heat, cook, or dry food. It is not designed for industrial or laboratory use.
7. As with any appliance, close supervision is necessary when it is used by children. Keep children away from the door when opening or closing it as they may bump themselves on the door or catch their fingers in the door.
8. Do not operate this appliance if it has a damaged cord or plug, if it is not working properly, or if it has been damaged or dropped.
9. This appliance should be repaired or serviced only by qualified service personnel. Contact the nearest authorized service facility for examination, repair, or adjustment.
10. Do not cover or block any openings on the appliance.

SAVE THESE INSTRUCTIONS

11. Do not tamper with or make any adjustments or repairs to the door.
12. Do not store this appliance outdoors. Do not use this product near water, for example, near a kitchen sink, in a wet basement, near a swimming pool, or similar locations.
13. Do not immerse the cord or plug in water.
14. Keep the cord away from heated surfaces. (including the back of the oven).
15. Do not let the cord hang over edge of table or counter.
16. When cleaning surfaces of the door and oven that come together when the door closes, use only mild, nonabrasive soaps, or detergents applied with a sponge or soft cloth. Unplug the plug before cleaning.
17. To reduce the risk of fire in the oven cavity:
 - a. Do not overcook food. Carefully attend appliance when paper, plastic, or other combustible materials are placed inside the oven to facilitate cooking.
 - b. Remove wire twist-ties from paper or plastic bags before placing the bags in the oven.
 - c. If materials inside the oven ignite, keep the oven door closed, turn the oven off, and disconnect the power cord, or shut off the power at the fuse or circuit breaker panel. If the door is opened, the fire may spread.
 - d. Do not use the cavity for storage purposes. Do not leave paper products, cooking utensils, or food in the cavity when not in use.
18. Liquids, such as water, milk, coffee, or tea can be overheated beyond the boiling point without appearing to be boiling. Visible bubbling or boiling when the container is removed from the microwave oven is not always present. THIS COULD RESULT IN VERY HOT LIQUIDS SUDDENLY BOILING OVER WHEN THE CONTAINER IS DISTURBED OR A SPOON OR OTHER UTENSIL IS INSERTED INTO THE LIQUID. To reduce the risk of injury:
 - a. Do not overheat liquid.
 - b. Stir liquid both before and halfway through heating it.
 - c. Do not use straight-sided containers with narrow necks.
 - d. After heating, allow the container to stand in the microwave oven for a short time before removing the container.

- e. Use extreme care when inserting a spoon or other utensil into the container.
19. Oversized foods or oversized metal utensils should not be inserted in microwave / toaster oven as they may create a fire or electric shock.
20. Do not clean with metal scouring pads. Piece can burn off the pad and touch electrical parts involving a risk of electric shock.
21. Do not use paper products when appliance is operated in the toaster mode.
22. Do not store any materials, other than manufacturer's recommended accessories, in this oven when not in use.
23. Do not cover racks or any other part of the oven with metal foil. This will cause overheating of the oven.

 **CAUTION**

1. Over The Range model Only
 - Clean Ventilating Hoods Frequently - Grease should not be allowed to accumulate on the hood of the filter.
 - When flaming foods under the hood, turn the fan on.
 - Use care when cleaning the vent-hood filter. Corrosive cleaning agents, such as lye-based oven cleaner, may damage the filter.
2. Push Button type model Only
 - Pre-caution for safe use to avoid possible exposure to excessive micro oven energy : Do not attempt to pull any part of the door by hand to open the door. Open the door only utilizing the push button located at front-right-bottom side.

GROUNDING INSTRUCTIONS

This appliance must be grounded. In the event of an electrical short circuit, grounding reduces the risk of electric shock by providing an escape wire for the electrical current. This appliance is equipped with a cord that includes a grounding wire and a grounding plug. The plug must be plugged into an outlet that is properly installed and grounded.

SAVE THESE INSTRUCTIONS

SAVE THESE INSTRUCTIONS

WARNING

Improper use of the grounding plug can result in a risk of electric shock.

- Plug into a grounded 3 prong outlet. Do not remove the third (grounding) prong. Do not use an adaptor or otherwise defeat the grounding plug.
- Consult a qualified electrician or service person if you do not understand the grounding instructions or if you are not sure if the appliance is properly grounded.
- We do not recommend using an extension cord with this appliance. If the power-supply cord is too short, have a qualified electrician or serviceman install an outlet near the appliance. However, if it is necessary to use an extension cord, read and follow the “Use of Extension Cords” section below.

USE OF EXTENSION CORDS

A short power-supply cord is provided to reduce the risk of your becoming entangled in or tripping over a longer cord. Longer cord sets or extension cords are available and you can use them if you exercise care. If you use a long cord or extension cord:

1. The marked electrical rating of the cord set or extension cord should be at least as great as the electrical rating of the appliance.
2. The extension cord must be a grounding-type 3-wire cord and it must be plugged into a 3-slot outlet.
3. The longer cord should be arranged so that it will not drape over the counter top or tabletop where it can be pulled on by children or tripped over accidentally. If you use an extension cord, the interior light may flicker and the speed of the blower may vary when the microwave oven is on. Cooking times may be longer too.

SAVE THESE INSTRUCTIONS

CRITICAL INSTALLATION WARNINGS

- ★ The installation of this appliance must be performed by a qualified technician or service company.
 - Failing to have a qualified technician install the oven may result in electric shock, fire, an explosion, problems with the product, or injury.
- Unpack the oven, remove all packaging material and examine the oven for any damage such as dents on the interior or exterior of the oven, broken door latches, cracks in the door, or a door that is not lined up correctly. If there is any damage, do not operate the oven and notify your dealer immediately.
- Make sure to install your oven in a location with adequate space. Remove all foreign substances such as dust or water from the power plug terminals and contact points using a dry cloth on a regular basis.
- Unplug the power plug and clean it with a dry cloth.
 - Failing to do so may result in electric shock or fire.
- Plug the power cord into a properly grounded 3 pronged outlet. Your oven should be the only appliance connected to this circuit.
- Sharing a wall socket with other appliances, using a power strip, or extending the power cord may result in electric shock or fire.
 - Do not use an electric transformer. It may result in electric shock or fire.
 - Ensure that the voltage, frequency and current provided match the product's specifications. Failing to do so may result in electric shock or fire.
- Keep all packaging materials out of the reach of children. Children may use them for play.

SAVE THESE INSTRUCTIONS

 This appliance must be properly grounded. Read and follow the specific “Grounding instructions” found in the beginning of this Section. Do not ground the appliance to a gas pipe, plastic water pipe, or telephone line.

- This may result in electric shock, fire, an explosion, or problems with the product.
- Never plug the power cord into a socket that is not grounded correctly and make sure that it is grounded in accordance with local and national codes.

Do not cut or remove the third (ground) prong from the power cord under any circumstances.

Connect the oven to a 20A circuit. If you connect the oven to a 15A circuit, make sure that the circuit breaker is operable.

 Do not install this appliance in a humid, oily, or dusty location, or in a location exposed to direct sunlight or water (rain drops).

- This may result in electric shock or fire.

Plug the power plug into the wall socket firmly. Do not use a damaged power plug, damaged power cord, or loose wall socket.

- This may result in electric shock or fire.

Do not mount over a sink.

Do not pull or excessively bend the power cord.

Do not twist or tie the power cord.

Do not hook the power cord over a metal object, place a heavy object on the power cord, insert the power cord between objects, or push the power cord into the space behind the appliance.

- This may result in electric shock or fire.

Do not pull the power cord when you unplug the oven.

- Unplug the oven by pulling the plug only.
- Failing to do so may result in electric shock or fire.



 When the power plug or power cord is damaged, contact your nearest service center for a replacement or repair.

SAVE THESE INSTRUCTIONS



CAUTION

INSTALLATION CAUTIONS

-  Position the oven so that the plug is easily accessible.
 - Failing to do so may result in electric shock or fire due to electric leakage.
-  Unplug the oven when it is not being used for long periods of time or during a thunder/lightning storm.
 - Failing to do so may result in electric shock or fire.



WARNING

CRITICAL USAGE WARNINGS

-  If the microwave appliance is flooded, please contact your nearest service center. Failing to do so may result in electric shock or fire.

Read and follow the specific “Precautions to Avoid Possible Exposure to Excessive Microwave Energy”, found in the beginning of this Safety Information Section.

If the microwave generates a strange noise, a burning smell or smoke, unplug it immediately and contact your nearest service center.

- Failing to do so may result in electric shock or fire.

In the event of a gas leak (propane gas, LP gas, etc.), ventilate the room immediately. Do not touch the microwave, power cord, or plug.

- Do not use a ventilating fan.
- A spark may result in an explosion or fire.

Take care that the door or any of the other parts do not come into contact with your body while cooking or just after cooking.

- Failing to do so may result in burns.

In the event of a grease fire on the surface units below the oven, smother the flaming pan on the surface unit by covering the pan completely with a lid, a cookie sheet, or a flat tray.

SAVE THESE INSTRUCTIONS

- ★ Never leave surface units beneath your oven unattended at high heat settings. Boil overs cause smoking and greasy spillovers that may ignite and spread if the vent fan is operating. To minimize automatic fan operation, use adequate sized cookware and use high heat on surface units only when necessary.

If materials inside the oven should ignite, keep the oven door closed, turn the oven off and disconnect the power cord, or shut off power at the fuse or circuit breaker panel. If the door is opened, the fire may spread.

- Always observe Safety Precautions when using your oven. Never try to repair the oven on your own. There is dangerous voltage inside. If the oven needs to be repaired, contact an authorized service center near you.

- ✂ Do not attempt to repair, disassemble, or modify the appliance yourself.

- Because a high voltage current enters the product chassis during operation, opening the chassis can result in electric shock or fire.
- You may be exposed to electromagnetic waves.
- When the oven requires repair, contact your nearest service center.

- 🔌 If any foreign substance such as water enters the microwave, unplug it and contact your nearest service center.

- Failing to do so may result in electric shock or fire.

- ⚠ Do not touch the power plug with wet hands.

- This may result in electric shock.

Do not turn the appliance off by unplugging the power plug while the appliance is in operation.

- Plugging the power plug into the wall socket again may cause a spark and result in electric shock or fire.

Keep all packaging materials well out of the reach of children. Packaging materials can be dangerous to children.

- If a child places a bag over its head, the child can suffocate.

- ⚠ Do not let children or any person with reduced physical, sensory or mental capabilities use this appliance unsupervised. Make sure that the appliance is out of the reach of children.

- Failing to do so may result in electric shock, burns or injury.

Do not touch the inside of the appliance immediately after cooking. The inside of the appliance will be hot.

- The heat on the inside of the oven can cause burns.

Do not put aluminum foil (except as specifically directed in this manual), metal objects (such as containers, forks, etc.) or containers with golden or silver rims into the microwave.

- These objects can cause sparks or a fire.

Do not use or place flammable sprays or objects near the oven.

- Heat from the microwave can cause flammable sprays to explode or burn.

- Failing to do so may result in electric shock or injury.

Do not tamper with or make any adjustments or repairs to the door. Under no circumstances should you remove the outer cabinet.

Do not store or use the oven outdoors.

USAGE CAUTIONS

- ★ If the surface of the microwave is cracked, turn it off.

- Failing to do so may result in electric shock.

Dishes and containers can become hot. Handle with care.

Hot foods and steam can cause burns. Carefully remove container coverings, directing steam away from your hands and face.

Remove lids from baby food before heating. After heating baby food, stir well to distribute the heat evenly. Always test the temperature by tasting before feeding the baby. The glass jar or surface of the food may appear to be cooler than the food in the interior, which can be so hot that it will burn the infant's mouth.

SAVE THESE INSTRUCTIONS

SAVE THESE INSTRUCTIONS

★ Make sure all cookware used in the oven is suitable for microwaving. Use microwavable cookware in strict compliance with such manufacturer's recommendations.

☐ Do not stand on top of the microwave or place objects (such as laundry, oven covers, lighted candles, lighted cigarettes, dishes, chemicals, metal objects, etc.) on the appliance.

- Items, such as a cloth, may get caught in the door.
- This may result in electric shock, fire, problems with the product, or injury.

Do not operate the appliance with wet hands.

- This may result in electric shock.

Do not spray volatile material such as insecticide onto the surface of the appliance.

- As well as being harmful to humans, it may also result in electric shock, fire or problems with the product.

Do not place the appliance over a fragile object such as a sink or glass object.

- This may result in damage to the sink or glass object.

Do not put your face or body close to the appliance while cooking or when opening the door just after cooking.

- Take care that children do not come too close to the appliance.
- Failing to do so may result in children burning themselves.

Do not place food or heavy objects over the door when opening the door.

- The food or object may fall and this may result in burns or injury.

Do not abruptly cool the door, the inside of the appliance, or the dish by pouring water over it during or just after cooking.

- This may result in damage to the appliance. The steam or water spray may result in burns or injury.

Do not cook without the glass tray in place on the oven floor. Food will not cook properly without the tray.

☐ Do not defrost frozen beverages in narrow-necked bottles. The containers can break.

Do not scratch the glass of the oven door with a sharp object.

- This may result in the glass being damaged or broken.

Do not store anything directly on top of the appliance when it is in operation.

Do not use sealed containers. Remove seals and lids before use. Sealed containers can explode due to buildup of pressure even after the oven has been turned off.



CRITICAL CLEANING INSTRUCTIONS

Do not clean the appliance by spraying water directly onto it.

Do not use benzene, thinner, or alcohol to clean the appliance.

- This may result in discoloration, deformation, damage, electric shock, or fire.

Before cleaning or performing maintenance, unplug the appliance from the wall socket and remove food waste from the door and cooking compartment.

- Failing to do so may result in electric shock or fire.

Take care not to hurt yourself when cleaning the appliance. (external/internal)

- You may hurt yourself on the sharp edges of the appliance.

Do not clean the appliance with a steam cleaner.

- This may result in corrosion.

Keep the inside of the oven clean. Food particles or spattered oils stuck to the oven walls or floor can cause paint damage and reduce the efficiency of the oven.



SAVE THESE INSTRUCTIONS

SAVE THESE INSTRUCTIONS

INSTALLING YOUR MICROWAVE OVEN

Place the oven on a flat level surface 85 cm above the floor. The surface should be strong enough to safely bear the weight of the oven.

NOT FOR BUILT-IN INSTALLATION

1. When you install your oven, make sure there is adequate ventilation for your oven by leaving at least 10 cm (4 inches) of space behind and, on the sides of the oven and 20 cm (8 inches) of space above.
 2. Remove all packing materials inside the oven.
 3. Install the roller ring and turntable. Check that the turntable rotates freely. (Turntable type model only)
 4. This microwave oven has to be positioned so that plug is accessible.
-  If the supply cord is damaged, it must be replaced by the manufacturer, its service agent or similarly qualified persons in order to avoid a hazard. For your personal safety, plug the cable into a proper AC earthed socket.
-  Do not install the microwave oven in hot or damp surroundings like next to a traditional oven or radiator. The power supply specifications of the oven must be respected and any extension cable used must be of the same standard as the power cable supplied with the oven. Wipe the interior and the door seal with a damp cloth before using your microwave oven for the first time.

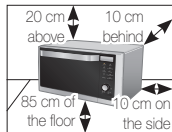

CLEANING THE TURNTABLE AND ROLLER RINGS

Clean the roller rings periodically and wash the turntable as required. You can wash the turntable safely in your dishwasher.

STORING AND REPAIRING YOUR MICROWAVE OVEN





If you need to store your microwave oven for a short or extended period of time, choose a dust-free, dry location. Dust and dampness may adversely affect the microwave parts.



- Do not repair, replace or service any part of your microwave oven yourself. Allow only a qualified service technician to perform repairs. If the oven is faulty and needs servicing, or you are in doubt about its condition, unplug the oven from the power outlet and contact your nearest service center.
- Do not use the oven if it is damaged, in particular, if the door or door seals are damaged. Door damage includes a broken hinge, a worn out seal, or distorted/bent casing.
- Do not remove the oven from its casing.
- This microwave oven is for home use only and is not intended for commercial use.

quick look-up guide





To cook food:

 <p>Microwave</p>	<p>1. Place the food in the oven. Press the Microwave button.</p>
 <p>Microwave</p>	<p>2. Press the Microwave button until the appropriate power level is displayed.</p>
	<p>3. Select the cooking time by turning the Dial knob as required.</p>
 <p>START</p>	<p>4. Press START/+30s button. Result: Cooking starts.</p> <ul style="list-style-type: none">• When cooking has finished, the oven will beep and flash "0" four times. The oven will then beep once time per minute until you open the door.

To +30s function:

 <p>START</p>	<p>Leave the food in the oven. Press START/+30s button one or more times for each extra 30 seconds that you want to add.</p>
--	---

To defrost food:

 <p>Defrost</p>	<p>1. Place the frozen food in the oven. Press the Defrost button.</p>
 <p>Defrost</p>	<p>2. Select the food category by pressing the Defrost button until the desired food category is selected.</p>
	<p>3. Select the weight by turning the Dial knob as required.</p>
 <p>START</p>	<p>4. Press START/+30s button. Result: Defrosting starts.</p> <ul style="list-style-type: none">• When defrosting has finished, the oven will beep and flash "0" four times. The oven will then beep once per minute until you open the door.

OVEN

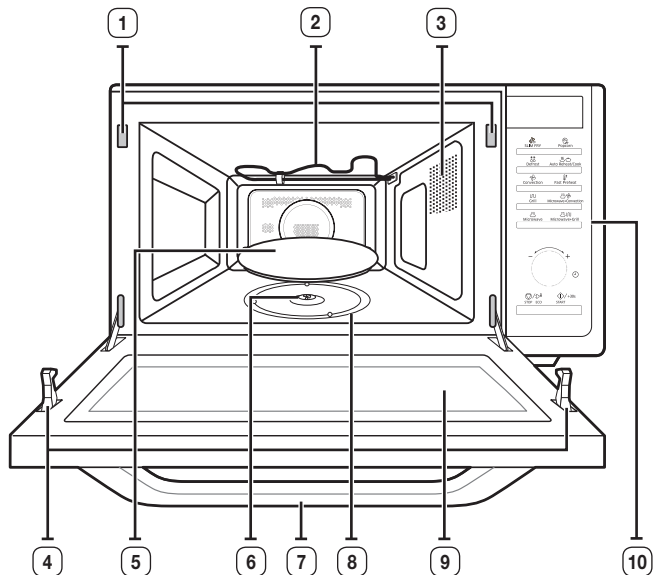

- | | |
|---------------------------|-------------------|
| 1. SAFETY INTERLOCK HOLES | 6. COUPLER |
| 2. HEATING ELEMENT | 7. DOOR HANDLE |
| 3. VENTILATION HOLES | 8. ROLLER RING |
| 4. DOOR LATCHES | 9. DOOR |
| 5. TURNTABLE | 10. CONTROL PANEL |

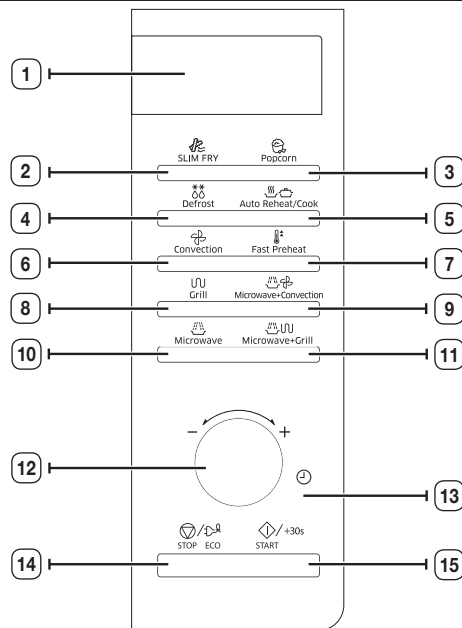

CONTROL PANEL



- | | |
|----------------------------|--|
| 1. DISPLAY | 9. MICROWAVE+CONVECTION
BUTTON |
| 2. SLIM FRY BUTTON | 10. MICROWAVE BUTTON |
| 3. POPCORN BUTTON | 11. MICROWAVE+GRILL BUTTON |
| 4. DEFROST BUTTON | 12. DIAL KNOB
(WEIGHT/SERVING/TIME) |
| 5. AUTO REHEAT/COOK BUTTON | 13. CLOCK SETTING BUTTON |
| 6. CONVECTION BUTTON | 14. STOP/ECO BUTTON |
| 7. FAST PREHEAT BUTTON | 15. START/+30s BUTTON |
| 8. GRILL BUTTON | |

ACCESSORIES

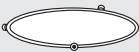
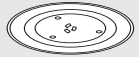
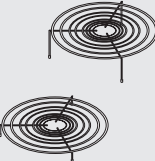
Depending on the model that you have purchased, some or all of the accessories listed below are included with your microwave.

	<p>1. * Roller ring, to be placed in the center of the oven. Purpose: The roller ring supports the turntable.</p>
	<p>2. * Turntable, to be placed on the roller ring with the center fitting on to the coupler. Purpose: The turntable serves as the main cooking surface. It can be easily removed for cleaning.</p>
	<p>3. * High rack, * Low rack, to be placed on the turntable. Purpose: The metal racks can be used to cook two dishes at the same time. A small dish can be placed on the turntable and a second dish on the rack. The metal racks can be used in grill, convection, and combination cooking.</p>
	<p>4. * Crusty plate, to be placed on the turntable. Purpose: The crusty plate is used to brown the bottom of food in the microwave or grill combination cooking modes and to keep pastry and pizza dough crispy.</p>

 **DO NOT** operate the microwave oven without the roller ring and turntable.

 **If you need an accessory marked with a *, you can buy it from the Samsung Contact Center (1-800-726-7864) or on-line at: (www.samsungparts.com)**

oven use

HOW A MICROWAVE OVEN WORKS

Microwaves are high-frequency electromagnetic waves. The microwaves cause molecules in the food to vibrate more quickly, releasing heat. This heat disperses through the food.

You can use your microwave oven to:

- Defrost
- Reheat
- Cook

Cooking Principle.

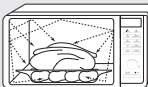
	<ol style="list-style-type: none"> 1. The microwaves generated by the magnetron reflected off cavity and are distributed uniformly as the food rotates on the turntable. The food is thus cooked evenly. 2. The microwaves are absorbed by the food up to a depth of about 1 inch (2.5 cm). Cooking then continues as the heat is dissipated within the food. 3. Cooking times vary according power level setting you use and the properties of the food: <ul style="list-style-type: none"> • Quantity and density • Water content • Initial temperature (refrigerated or not)
---	--

 As the center of the food is cooked by heat dissipation, cooking continues even after you have taken the food out of the oven. You should use the standing times specified in recipes and in this booklet to ensure:

- Even cooking of the food right to the center
- The same temperature throughout the food

CHECKING IF YOUR OVEN IS OPERATING CORRECTLY

The following simple procedure enables you to confirm that your oven is working correctly at all times. If you are in doubt, refer to the section entitled "Troubleshooting" on the page 35-36.

- ☑ The oven must be plugged into an appropriate wall socket. The turntable must be in position in the oven. If a power level other than the maximum (100 % - 900 W) is used, the water takes longer to boil.

Open the oven door by pulling the handle on the upper side of the door. Place a glass of water on the turntable. Close the door.

	<p>Press the START/+30s button and set the time to 4 or 5 minutes by pressing the START/+30s button the appropriate number of times.</p> <p>Result: The oven heats the water for 4 or 5 minutes. The water should then be boiling.</p>
---	---





SETTING THE TIME

Your microwave oven has an built-in clock. When power is supplied, "0", "88:88", or "12:00" is automatically displayed on the display.

The time can be displayed in 12-hour notation. You must set the clock:

- When you first install your microwave oven
- After a power failure

- ☑ Do not forget to reset the clock when you switch to and from summer and winter time.





	<p>1. To display the time in the 12-hour notation, press the Clock button.</p>
	<p>2. Turn the Dial knob to set the hour.</p>
	<p>3. Press the Clock button.</p>
	<p>4. Turn the Dial knob to set the minute.</p>
	<p>5. When the right time is displayed, press the Clock button to start the clock.</p> <p>Result: The time is displayed whenever you are not using the microwave oven.</p>

COOKING/REHEATING

The following procedure explains how to cook or reheat food.

 ALWAYS check your cooking settings if you will be leaving the oven unattended.

Open the door. Place the food in the center of the turntable. Close the door.

 Microwave <input type="text"/>	<p>1. Press the Microwave button.</p> <p>Result: The following indications are displayed:  (microwave mode)</p>
 Microwave <input type="text"/>	<p>2. Select the appropriate power level by pressing the Microwave button again until the corresponding power level is displayed. Refer to the power level table on the next page for further details.</p>
	<p>3. Set the cooking time by turning the Dial knob.</p> <p>Result: The cooking time is displayed.</p>
 START <input type="text"/>	<p>3. Press the START/+30s button.</p> <p>Result: The oven light comes on and the turntable starts rotating. Cooking starts. When it has finished:</p> <ul style="list-style-type: none"> The oven beeps and flashes "0" four times. The oven will then beep once per minute until you open the door.

 Never switch the microwave oven on when it is empty.

 If you would like to know the current Power Level of the oven cavity, press the **Microwave** button once. If you would like to change the power level during cooking, press the **Microwave** button two or more times to select the desired power level.

Quick Start:

 If you want to heat a dish for a short period of time at maximum power (900 W), press the **START/+30s** button once for each 30 seconds of cooking time. The oven starts immediately.

POWER LEVELS AND TIME VARIATIONS



The power level function lets you control the amount of energy generated by the microwave and thus the time required to cook or reheat your food, according to its type and quantity. You can choose between 10 power levels.

PL:Hi	(High)	PL:50	(Medium)
PL:90	(Sauté)	PL:40	(Medium low)
PL:80	(Reheat)	PL:30	(Low)
PL:70	(Medium high)	PL:20	(Defrost)
PL:60	(Simmer)	PL:10	(Warm)

The cooking times given in recipes and in this booklet correspond to the specific power level indicated.

If you select a...	Then the cooking time will be...
Higher power level	Decreased
Lower power level	Increased

ADJUSTING THE COOKING TIME

 START <input type="text"/>	<p>You can increase the cooking time by pressing the START/+30s button once for each 30 seconds you want to add.</p> <ul style="list-style-type: none"> Check how cooking is progressing at any time simply by opening the door <p>To increase the remaining cooking time, press the START/+30s button once for each 30 seconds that you want to add.</p> <ul style="list-style-type: none"> Example: To add three minutes, press the START/+30s button 6 times.
	<p>You can also increase/decrease the cooking time by turning the Dial knob.</p> <ul style="list-style-type: none"> To increase cooking time, turn the dial knob to the right. To decrease cooking time, turn the dial knob to the left.

STOPPING THE COOKING

You can stop cooking at any time so that you can:

- Check the food
- Turn the food over or stir it
- Let it stand

To stop the cooking...	Then...
Temporarily	Temporarily : Open the door or press the stop button once. Result: Cooking stops. To resume cooking, close the door again and press the START/+30s button.
Completely	Completely : Press the stop button twice. Result: Cooking stops. If you want to cancel the cooking settings, press the STOP/ECO button again.

SETTING THE ENERGY SAVE MODE

The oven has an energy save mode. This feature saves electricity when the oven is not in use by turning off the display entirely, including the clock display. Normally, when the oven is not in use, the oven enters standby mode and continues to display the clock.

 STOP ECO <input type="text"/>	<ul style="list-style-type: none"> • Press the STOP/ECO button. Result: Display off. • To cancel energy save mode, open the door or press the STOP/ECO button. The display shows the current time, and the oven is ready for use.
---	--

Auto energy saving function



If you do not select a function when you are setting the microwave or if you have stopped the microwave temporarily, the Eco function is cancelled and clock will be displayed after 25 minutes.

If you leave the door open, the oven lamp turns off after 5 minutes.

USING THE POPCORN FEATURE

The Popcorn feature has a pre-programmed cooking time and power level. You do not need to set either the cooking time or the power level.

Open the door. Place the food in the center of the turntable. Close the door.

 Popcorn <input type="text"/>	1. Press the Popcorn button.
 START <input type="text"/>	2. Press START/+30s button. Result: <ul style="list-style-type: none"> • Cooking starts. • The oven beeps when cooking is complete.

 Use only containers that are microwave-safe.





The following table displays the Popcorn program, food quantities, and instructions.

Code/Food	Serving Size	Instructions
1 Popcorn	3.0-3.5 oz. 1 package	Use only one microwave popcorn bag at a time. Be careful when removing the heated bag from the oven and opening it.

USING THE DEFROST FEATURES

The Defrost features enables you to defrost meat, poultry, fish, bread, cake and fruit. The defrost time and power level are set automatically. You simply select the program and the weight.

Open the door. Place the frozen food on a microwave safe dish in the center of the turntable. Close the door.

 <input type="text"/>	1. Press the Defrost button.
 <input type="text"/>	2. Select the type of food that you are defrosting by pressing the Defrost button repeatedly. Refer to the table on the following page for a description of the various preprogrammed settings.
	3. Select the weight of the food by turning the Dial knob .
 <input type="text"/>	4. Press START/+30s button. Result: <ul style="list-style-type: none"> • Defrosting begins. • The oven beeps half way through defrosting to remind you to turn the food over.
 <input type="text"/>	5. Press the STOP/ECO button to finish defrosting. Result: When defrosting has finished, the oven will beep and flash "0" four times. The oven will then beep once per minute until you open the door.

 Use only containers that are microwave-safe.

 You can also defrost food manually. To do so, set the micro wave to the 20 % power level. Refer to the section entitled "Defrosting" on page 31 for further details.

The following table lists the various Defrost programs, food quantities, and instructions. Remove all packaging material before defrosting.

Place meat, poultry, and fish on a flat glass plate or on a ceramic plate, arrange bread and cake on kitchen paper.





Code/Food	Serving Size	Instructions
1 Meat	0.1-3.5 lbs	Shield the edges with aluminium foil. Turn the meat over when the oven beeps. This program is suitable for beef, lamb, pork, steaks, chops, minced meat. Let stand for 20-60 minutes.
2 Poultry	0.1-3.5 lbs	Shield the leg and wing tips with aluminium foil. Turn the poultry over when the oven beeps. This program is suitable for whole chicken as well as for chicken parts. Let stand for 20-60 minutes.
3 Fish	0.1-3.5 lbs	Shield the tail of a whole fish with aluminium foil. Turn the fish over when the oven beeps. This program is suitable for whole fishes as well as for fish filets. Let stand for 20-60 minutes.
4 Bread/Cake	0.1-2.0 lbs	Put bread horizontally on a piece of kitchen paper and turn over as soon as the oven beeps. Place cake on a ceramic plate and if possible, turn over as soon as the oven beeps. (The oven keeps operating and only stops when you open the door.) This program is suitable for all kinds of bread, sliced or whole, as well as for bread rolls and baguettes. Arrange bread rolls in a circle. This program is also suitable for all kinds of yeast cakes, biscuits, cheese cakes, and puff pastry. It is not suitable for short/crust pastry, fruit and cream cakes or for cake with chocolate topping. Let stand for 10-30 minutes.
5 Fruit	0.1-1.5 lbs	Spread fruit evenly into a flat glass dish. This program is suitable for all kind of fruits. Let stand for 5-20 minutes.

USING THE AUTO REHEAT/COOK FEATURES

The Auto Reheat/Cook features have pre-programmed cooking times. You do not need to set either the cooking times or the power level.

You can adjust the size of the serving by turning the **Dial knob**.

Open the door. Place the food in the center of the turntable. Close the door.

 Auto Reheat/Cook <input type="text"/>	1. Press the Auto Reheat/Cook button.
 Auto Reheat/Cook <input type="text"/>	2. Select the type of food that you are cooking by pressing the Auto Reheat/Cook button. Refer to the table on the following page for a description of the various preprogrammed settings.
	3. Select the type of food by turning the Dial knob .
 Auto Reheat/Cook <input type="text"/>	4. Select the serving size of the food by pressing the Auto Reheat/Cook button.
 START <input type="text"/>	5. Press the START/+30s button. Result: The food is cooked according to the preprogrammed setting selected. <ul style="list-style-type: none"> When cooking has finished, the oven will beep and flash "0" four times. The oven will then beep once per minute until you open the door.

 Use only cookware that is microwave-safe.

The following table lists the Auto Reheat programs, food quantities, and instructions.

1. Auto Reheat

Code/Food	Serving Size	Instructions
1-1 Dinner Plate	1 serving (1 plate)	Use only precooked, refrigerated foods. Cover the plate with vented plastic wrap or waxed paper tucked under the plate. Contents: 3 - 4 oz. meat, poultry, or fish (up to 6 oz. with bone) ½ cup starch (potatoes, pasta, rice, etc.) ½ cup vegetables (about 3 - 4 oz.)
1-2 Casserole	1 to 4 servings	Cover the plate with a lid or vented plastic wrap. Stir the food once before serving. Contents:
1-3 Pasta		Casserole, refrigerated foods. Pasta: canned spaghetti and ravioli.

 Use oven gloves when taking out food.

The following table lists the Auto Cook programs, food quantities, and instructions.

2. Auto Cook

Code/Food	Serving Size	Instructions
2-1 Beverage	1 serving (½ cup) 2 servings (1 cup) 3 servings (2 cups)	Use a measuring cup or mug and do not cover. Place the beverage in the oven. After heating, stir well.
2-2 Chicken Breast	1 serving (2 pieces) 2 servings (4 pieces)	Place the chicken breasts on a microwave safe plate and cover with plastic wrap. Cook to an internal temperature of 170 °F. Let stand for 5 minutes.
2-3 Frozen Breakfast	5 (4-6 oz.) 8 (7-8 oz.)	Follow the package instructions for covering and letting stand. Use this button for frozen sandwiches, breakfast entrees, pancakes, waffles, etc.
2-4 Frozen Dinner	9 (8-10 oz.) 12 (11-14 oz.) 16 (15-18 oz.)	Remove the food from its wrapping and follow the instructions on the box for covering and letting stand.



USING THE SLIM FRY COOK FEATURES

The nine Slim Fry cook features have pre-programmed cooking times.

You do not need to set either the cooking times or the power level.

You can change the slim fry cook category by press the **SLIM FRY** button.

To begin, place the food in the center of the turntable and close the door.

	1. Select the type of food that you are cooking by pressing the SLIM FRY button one or more times. (Refer to the table on the side.)
	2. Select the weight of food by turning the Dial knob .
	3. Press the START/+30s button.

 ALWAYS use microwave-safe and oven-proof cookware. Glass or ceramic dishes are ideal as they allow the microwaves to penetrate the food evenly. ALWAYS use oven gloves when touching the cookware in the oven, as they will be very hot.

The following table lists the 9 Slim Fry auto programs for frying along with the food quantities and instructions. The Slim Fry programs use a combination of convection, top heater, and microwave cooking. As a result, you will use less oil compared to frying with an oil fryer and get equally tasty results.

Code/Food	Serving Size	Instructions
1 Frozen Oven Chips	2 servings (0.7-0.8 lbs.) 4 servings (1.0-1.1 lbs.)	Distribute frozen oven chips evenly on the crusty plate. Set plate on high rack. Open the door and turn over the chips after beep sounds. Press Start to continue. (The oven keeps operating if you do not open the door.)
2 Frozen Prawns, Breaded	1 serving (0.5-0.6 lbs.) 2 servings (0.7-0.8 lbs.)	Distribute frozen breaded prawns evenly on the crusty plate. Set plate on low rack.
3 Frozen Chicken Nuggets	1 serving (0.5-0.6 lbs.) 2 servings (0.8-0.9 lbs.)	Distribute frozen chicken nuggets evenly on the crusty plate. Set plate on low rack. Open the door and turn over the nuggets after beep sounds. Press Start to continue. (The oven keeps operating if you do not open the door.)
4 Chicken Wings	1 serving (0.3-0.4 lbs.) 2 servings (0.5-0.6 lbs.)	Weigh chicken wings and brush with oil and spices. Place them evenly on high rack. Open the door and turn over the wings after beep sounds. (The oven will stop cooking.) Press Start to continue. Let stand for 1-2 minutes.

Code/Food	Serving Size	Instructions
5 Homemade French Fries	2 servings (0.7-0.8 lbs.) 4 servings (1.0-1.1 lbs.)	Preheat the oven up to 400 °F using the fast preheat function. Use hard to medium potatoes. Wash and peel potatoes and cut into sticks about 3/8 inches thick (10 mm). Soak in cold water for 30 minutes. Dry them with a towel, weigh them and brush with 1 teaspoon olive oil. Distribute homemade fries evenly on the crusty plate. Set plate on low rack. Open the door and turn over the fries after beep sounds. Press Start to continue. (The oven keeps operating if you do not open the door. Let stand for 1-2 minutes.
6 Potato Wedges	1 serving (0.5-0.6 lbs.) 2 servings (0.7-0.8 lbs.) 3 servings (0.9-1.0 lbs.)	Wash normal sized potatoes and cut them into wedges. Brush with olive oil and spices. Put them with the cut side on the crusty plate. Set plate on high rack. Let stand for 1-2 minutes.
7 Frozen Potato Croquettes	1 serving (0.5-0.6 lbs.) 2 servings (0.7-0.8 lbs.)	Distribute frozen potato croquettes evenly on the crusty plate. Set plate on low rack.
8 Drumsticks	1 serving (0.5-0.6 lbs.) 2 servings (0.7-0.8 lbs.) 3 servings (0.9-1.0 lbs.)	Weigh drumsticks and brush with oil and spices. Place them evenly on high rack. Open the door and turn over the drumsticks after beep sounds. The oven will stop cooking. Press Start to continue. Let stand for 1-2 minutes.
9 Frozen Onion Ring	1 serving (0.2-0.3 lbs.) 2 servings (0.5-0.6 lbs.)	Distribute frozen onion rings evenly on the crusty plate. Set plate on low rack.

MULTISTAGE COOKING







Your microwave oven can be programmed to cook food in up to three stages.



Example: You want to defrost a 3.3 lbs. chicken and cook it without having to reset the oven after each stage. You can do this in three continuous stages:

- Defrosting
- Microwave cooking for 30 minutes
- Grill for 15 minutes

 Defrosting must be the first stage. Combination and Grill cooking can only be used once during the remaining two stages. However microwave cooking can be used twice (at two different power levels).

The Convection, Microwave+Convection, and Fast Preheat mode can not be used in Multistage cooking.





 Defrost <input type="text"/>	1. Press the Defrost button.
 Defrost <input type="text"/>	2. Select the type of food that you are cooking by pressing the Defrost button.
	3. Set the weight by turning the Dial knob the appropriate number of times. (3.3 lbs. as shown in the example).
 Microwave <input type="text"/>	4. Press the Microwave button.
 Microwave <input type="text"/>	5. Set the microwave power level by pressing the Microwave button to select the appropriate Power Level (50 % as shown in the example).
	6. Set the cooking time by turning the Dial knob . (30 minutes as shown in the example).

 Grill <input type="text"/>	7. Press the Grill button.
	8. Set the cooking time by turning the Dial knob . (15 minutes as shown in the example).
 START <input type="text"/>	9. Press START/+30s button. Result: Cooking starts: <ul style="list-style-type: none"> • When cooking has finished, the oven will beep and flash "0" four times. The oven will then beep once per minute until you open the door.

FAST PREHEATING THE OVEN

For convection cooking, we recommend that you preheat the oven to the appropriate temperature before placing the food in the oven. When the oven reaches the selected temperature, it maintains the temperature for approximately 10 minutes, and then switches off automatically.

Check if the heating element is in the correct position for the type of cooking that you require.

 Fast Preheat <input type="text"/>	<p>1. Press the Fast Preheat button. Result: The following indications are displayed: 400 °F (temperature)</p>
 Fast Preheat <input type="text"/>	<p>2. Press the Fast Preheat button one or more times to set the temperature. (Temperature : 400, 375, 350, 325, 300, 250, 200, 100 °F)</p>
 START <input type="text"/>	<p>3. Press the START/+30s button. Result: The oven is preheated to the selected temperature.</p> <ul style="list-style-type: none"> The display times are 8 seconds for the selected cooking mode and 2 seconds for the preset temperature in sequence. Ex) In fast preheat mode at 400 °F <div style="display: flex; justify-content: space-around; align-items: center;"> <div style="text-align: center;">  (displayed for 8 seconds) </div> <div style="text-align: center;">  (displayed for 2 seconds) </div> </div> <ul style="list-style-type: none"> When the oven reaches the preset temperature, it beeps 6 times. The temperature is maintained for 10 minutes. After 10 minutes, the microwave beeps 4 times and the operation stops.







 If you would like to know the current temperature of the oven cavity, press the **Fast Preheat** button.

COOKING BY CONVECTION

The convection mode cooks food in the same way as in a traditional oven. The microwave mode is not used. You can set the temperature, as required, in a range varying from 100 °F to 400 °F in 8 preset levels. The maximum cooking time is 60 minutes.

-  If you want to preheat the oven quickly, see Fast Preheating on this page.
- Always use oven gloves when touching cookware in the oven, as it will be very hot.
 - You can get better cooking and browning if you use the low rack.

Check if the heating element is in the horizontal position and if the turntable is in position. Open the door and place the cookware on the low rack or on the turntable.

 Convection <input type="text"/>	<p>1. Press the Convection button.</p>
 Convection <input type="text"/>	<p>2. Press the Convection button once or more times to set the temperature. (Temperature : 400, 375, 350, 325, 300, 250, 200, 100 °F)</p>
	<p>3. Set the cooking time by turning the Dial knob.</p>
 START <input type="text"/>	<p>4. Press the START/+30s button. Result: Cooking starts:</p> <ul style="list-style-type: none"> The microwave displays the preset cooking time for 8 seconds and then the preset temperature for 2 seconds in sequence. Ex) 30 minutes of cooking time at 400 °F <div style="display: flex; justify-content: space-around; align-items: center;"> <div style="text-align: center;">  (displayed for 8 seconds) </div> <div style="text-align: center;">  (displayed for 2 seconds) </div> </div> <ul style="list-style-type: none"> When cooking has finished, the oven will beep and flash "0" four times. The oven will then beep one time per minute.

 If you would like to know the current temperature of the oven cavity, press the **Fast Preheat** button.

 Be careful. The Grill heater may work intermittently while the convection mode is operating.

CHOOSING THE PROPER COOKWARE



Traditional convection cooking does require cookware. You should, however, use only cookware that you would use in your normal oven.

Microwave-safe containers are not usually suitable for convection cooking. Don't use plastic containers, dishes, paper cups, towels, etc.

If you want to select a combined cooking mode (microwave and grill or convection), use only cookware that is microwave-safe and oven-proof.

 For further details on suitable cookware and utensils, refer to the Cookware Guide on page 24-25.

GRILLING

The grill enables you to heat and brown food quickly, without using microwaves.

- Always use oven gloves when handling cookware in the oven, as the cookware will be very hot.
- You can get better cooking and grilling results if you use the high rack.

	<p>1. Open the door and place the food on the rack.</p>
	<p>2. Press the Grill button. Result: The following indicator is displayed:  (grill mode)</p> <ul style="list-style-type: none"> • You cannot set the temperature of the grill.
	<p>3. Set the grilling time by turning the Dial knob.</p> <ul style="list-style-type: none"> • The maximum grilling time is 60 minutes.
	<p>4. Press the START/+30s button. Result: Grilling starts.</p> <ul style="list-style-type: none"> • When cooking has finished, the oven will beep and flash "0" four times. The oven will then beep once per minute until you open the door.

COMBINING MICROWAVE COOKING AND THE GRILL

You can also combine microwave cooking with the grill to cook quickly and brown at the same time.

-  **ALWAYS** use microwave-safe and oven-proof cookware. Glass or ceramic dishes are ideal as they allow the microwaves to penetrate the food evenly. **ALWAYS** use oven gloves when handling cookware in the oven, as the cookware will be very hot.

Open the door. Place the food on the rack best suited to the type of food to be cooked. Place the rack on the turntable. Close the door.

	<p>1. Press the Microwave+Grill button. Result: The following indicators are displayed:  (microwave & grill combi mode) PL:30 (30 %) (output power)</p> <ul style="list-style-type: none"> • You cannot set the temperature of the grill or set the power level.
	<p>2. Set the cooking time by turning the Dial knob.</p> <ul style="list-style-type: none"> • The maximum cooking time is 60 minutes.
	<p>3. Press the START/+30s button. Result:</p> <ul style="list-style-type: none"> • Combination cooking starts. • When cooking has finished, the oven will beep and flash "0" four times. The oven will then beep once per minute until you open the door.







COMBINING MICROWAVE COOKING AND CONVECTION

Combination cooking uses both microwave energy and convection heating. No preheating is required as the microwave energy is immediately available. Many foods can be cooked in combination mode, particularly:

- Roast meats and poultry
- Pies and cakes
- Egg and cheese dishes

 ALWAYS use microwave-safe and oven-proof cookware. Glass or ceramic dishes are ideal as they allow the microwaves to penetrate the food evenly. ALWAYS use oven gloves when handling cookware in the oven, as the cookware will be very hot. You can get better cooking and browning if you use the low rack.

Open the door. Place the food on the turntable or on the low rack which should then be placed on the turntable. Close the door.

 Microwave+Convection 	<p>1. Press the Microwave+Convection button.</p> <p>Result: The following indicators are displayed:</p> <p> (microwave & convection combi mode)</p> <p>400 °F (temperature : switches to the following temperature mode in 2 seconds)</p>
 Microwave+Convection 	<p>2. Select the temperature by pressing the Microwave+Convection button.</p> <p>The power level is fixed 30 %.</p> <p>(Temperature : 400, 375, 350, 325, 300, 250, 200, 100 °F)</p>
	<p>3. Set the cooking time by turning the Dial knob.</p> <ul style="list-style-type: none"> • The maximum cooking time is 60 minutes.



 START

4. Press the **START/+30s** button.

Result:

- Combination cooking starts.
- The oven is heated to the selected temperature and then microwave cooking continues until the cooking time is over.
- The microwave displays the preset cooking time for 8 seconds and then the preset temperature for 2 seconds in sequence.
Ex) 30 minutes of cooking time at 400 °F

 (displayed for 8 seconds)





 (displayed for 2 seconds)

- When cooking has finished, the oven will beep and flash "0" four times. The oven will then beep once per minute until you open the door.

 If you would like to know the current temperature of the oven cavity, press the **Fast Preheat** button.

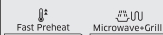

TURNING THE BEEPER OFF

You can switch the beeper off whenever you want.

	<p>1. Press the Fast Preheat button and Microwave+Grill buttons at the same time for 1 second.</p> <p>Result:</p> <ul style="list-style-type: none"> The following indicator is displayed.  <ul style="list-style-type: none"> The oven does not beep when you press a button.
	<p>2. To switch the beeper back on, press the Fast Preheat button and Microwave+Grill buttons again at the same time for 1 second.</p> <p>Result:</p> <ul style="list-style-type: none"> The following indicator is displayed.  <ul style="list-style-type: none"> The oven beeps when you press a button.

SAFETY-LOCKING YOUR MICROWAVE OVEN

Your microwave oven has a special child safety program which enables you to lock the oven so that children or anyone unfamiliar with it cannot operate it accidentally.

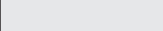
	<p>1. Press the Grill button and Microwave+Conv buttons at the same time for 1 second.</p> <p>Result:</p> <ul style="list-style-type: none"> The oven is locked. No functions can be selected. The display shows "L". 
	<p>2. To unlock the oven, press the Grill button and Microwave+Conv buttons again at the same time for 1 second.</p> <p>Result: The oven can be used normally.</p>

cookware guide

For food to cook in the microwave oven, the microwaves must be able to penetrate the food without being reflected or absorbed by the dish.

It is important to choose the correct cookware, therefore, look for cookware that is marked microwave-safe.

The following table lists various types of cookware and indicates if and how they should be used in a microwave oven.

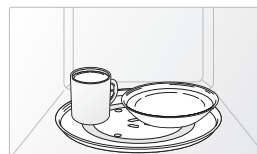

MICROWAVE-SAFE UTENSILS

If you are not sure whether an item is microwave-safe or not, you can perform the following simple test:

- Place 1 cup of water (in a glass-measuring cup) inside your oven next to the item to be tested.
- Press the **Add 30 Sec.** button twice to heat them both for one minute at high power.

After one minute, the water should be warm and the item you are testing should be cool. If the dish is warm, then it is absorbing microwave energy and is not microwave-safe.

Cookware	Microwave-safe	Comments
Aluminum foil	⚠	Can be used in small quantities to protect areas against overcooking. Arcing can occur if the foil is too close to the oven wall or you use too much foil.
Browning plate	✓	Do not preheat for more than eight minutes.
Disposable polyester cardboard	✓	Some frozen foods are packaged in these materials.

Cookware	Microwave-safe	Comments
Fast-food packaging Polystyrene cups/containers Paper bags or newspaper Recycled paper or metal trims	✓ — —	Can be used to warm food. Overheating may cause the polystyrene to melt. May catch fire. May cause arcing.
Glassware Oven-to-table ware Fine glassware Glass jars	✓ ✓ ✓	Can be used, unless decorated with a metal trim. Can be used to warm foods or liquids. Delicate glass may break or crack if heated suddenly. Regular glass is too thin to be used in a microwave, and can shatter.
Metal Dishes, Utensils Freezer bag twist ties	— —	May cause arcing or fire. May cause arcing or fire.
Paper Plates, cups, napkins and kitchen paper Recycled paper	✓ ✓	For short cooking times and warming. Also to absorb excess moisture. Do not use recycled paper towels, which may contain metal and may catch fire or cause arcing.

Cookware	Microwave-safe	Comments
Plastic Containers Cling film Freezer bags	✓ ✓ △	Can be used if heat-resistant thermoplastic. Some plastics may warp or discolor at high temperatures. Do not use Melamine plastic. Can be used to retain moisture. Avoid wrapping the food too tightly. Take care when removing the film as hot steam will escape. Only if boilable or oven-proof. Should not be airtight. Pierce with a fork if necessary.
Wax or grease-proof paper	✓	Can be used to retain moisture and prevent spattering.
Thermometer	✓	Use only those marked "Microwave-safe" and follow the directions. Check the temperature in several places. You can use conventional thermometers once the food has been removed from the oven.
Straw, wicker, and wood	△	Use only for short-term heating, as these materials are flammable.
Ceramic, porcelain, and stoneware	✓	Porcelain, pottery, glazed earthenware and bone china are usually suitable, unless decorated with a metal trim.

✓ : Recommended to use △ : Use with Caution — : Unsafe to use / Do not use

cooking guide

Microwave energy actually penetrates food and is attracted and absorbed by the water, fat and sugar in the food. The microwaves cause the molecules in the food to move rapidly. The rapid movement of these molecules creates friction and the resulting heat cooks the food.

GENERAL MICROWAVE TIPS

Dense foods, such as potatoes, take longer to heat than lighter foods. Foods with a delicate texture should be heated at a low power level to prevent them from becoming tough.

Foods with a non-porous skin, such as potatoes or hot dogs, should be pierced to prevent bursting.

Putting heating oil or fat in the microwave is not recommended. Fat and oil can suddenly boil over and cause severe burns.

Some ingredients heat faster than others. For example, the jelly in a jelly doughnut will be hotter than the dough. Keep this in mind to avoid burns.

The altitude and the type of cookware you are using can affect the cooking time. When trying a new recipe, use the minimum cooking time and check the food occasionally to prevent overcooking.

Home canning in the microwave oven is not recommended because not all harmful bacteria may be destroyed by the microwave heating process.

Although microwaves do not heat the cookware, the heat from the food is often transferred to the cookware. Always use pot holders when removing food from the microwave and instruct children to do the same.

Making candy in the microwave is not recommended as candy can be heated to very high temperatures. Keep this in mind to avoid injury.

COOKING TECHNIQUES

 If the oven is set to cook for more than 20 minutes, it will automatically adjust to 70 percent power after 20 minutes to avoid overcooking.

Stirring

Open the microwave door and stir foods such as casseroles and vegetables occasionally while cooking to distribute heat evenly. Food at the outside of the dish absorbs more energy and heats more quickly, so stir from the outside towards the center. The oven will turn off when you open the door to stir your food.

Arrangement

Arrange unevenly shaped foods, such as chicken pieces or chops, with the thicker, meatier parts toward the outside of the turntable where they can receive more microwave energy. To prevent overcooking, place thin or delicate parts towards the center of the turntable.

Shielding

Shield food with narrow strips of aluminum foil to prevent overcooking. Areas that need shielding include poultry wing-tips, the ends of poultry legs, and corners of square baking dishes. Use only small amounts of aluminum foil. Larger amounts can damage your oven.

Turning

Turn foods over midway through the cooking cycle to expose all parts to the microwave energy. This is especially important with large items such as roasts.

Standing

Foods cooked in the microwave build up internal heat and continue to cook for a few minutes after the oven stops. Let foods stand to complete the cooking process, especially foods such as roasts and whole vegetables. Roasts need this time to complete cooking in the center without overcooking the outer areas. All liquids, such as soup or hot chocolate, should be shaken or stirred when cooking is complete. Let liquids stand a moment before serving. When heating baby food, stir well and test the temperature before serving.

Adding moisture

Microwave energy is attracted to water molecules. Food that is uneven in moisture content should be covered or allowed to stand so that the heat disperses evenly. Add a small amount of water to dry food to help it cook.

Venting

After covering a dish with plastic wrap, vent the plastic wrap by turning back one corner to let excess steam escape.

Cooking guide for frozen vegetables

Use a suitable glass pyrex bowl with lid. Cook covered for the minimum time – see table. Continue cooking to get the result you prefer.
Stir twice during cooking and once after cooking. Add salt, herbs, or butter after cooking. Cover during standing time.

Food	Serving Size	Power	Time (min.)
Spinach	0.3 lbs.	60 %	5-6
	Instructions Add 15 ml (1 tbsp.) cold water. Let stand for 2-3 minutes.		
Broccoli	0.7 lbs.	60 %	8-9
	Instructions Add 30 ml (2 tbsp.) cold water. Let stand for 2-3 minutes.		
Peas	0.7 lbs.	60 %	7-8
	Instructions Add 15 ml (1 tbsp.) cold water. Let stand for 2-3 minutes.		
Green Beans	0.7 lbs.	60 %	7½-8½
	Instructions Add 30 ml (2 tbsp.) cold water. Let stand for 2-3 minutes.		
Mixed Vegetables (Carrots/Peas/Corn)	0.7 lbs.	60 %	7-8
	Instructions Add 15 ml (1 tbsp.) cold water. Let stand for 2-3 minutes.		
Mixed Vegetables (Chinese Style)	0.7 lbs.	60 %	7½-8½
	Instructions Add 15 ml (1 tbsp.) cold water. Let stand for 2-3 minutes.		

Cooking guide for fresh vegetables

Use a suitable glass pyrex bowl with lid. Add 30-45 ml cold water (2-3 tbsp.) for every 0.6 lbs. unless another water quantity is recommended – see table. Cook covered for the minimum time – see table. Continue cooking to get the result you prefer. Stir once during and once after cooking. Add salt, herbs, or butter after cooking. Cover during a standing time of 3 minutes.

Hint: Cut the fresh vegetables into even sized pieces. The smaller they are cut, the quicker they will cook.

Food	Serving Size	Power	Time (min.)
Broccoli	0.6 lbs.	100 %	3-4
	1.0 lbs.		5½-6
Instructions Prepare even sized florets. Arrange the stems so they point to the center. Let stand for 3 minutes.			
Brussels Sprouts	1.0 lbs.	100 %	4½-5
	Instructions Let stand 60-75 ml (5-6 tbsp.) water. Let stand for 3 minutes.		
Carrots	1.0 lbs.	100 %	3-4
	Instructions Cut carrots into even sized slices. Let stand for 3 minutes.		
Cauliflower	0.6 lbs.	100 %	3½-4
	1.0 lbs.		6-7
Instructions Prepare even sized florets. Cut big florets in half. Arrange stems so they point to the center. Let stand for 3 minutes.			
Zucchini	0.6 lbs.	100 %	3½-4
	Instructions Cut zucchini into slices. Add 30 ml (2 tbsp.) water or a knob of butter. Cook until just tender. Let stand for 3 minutes.		
Eggplant	0.6 lbs.	100 %	2½-3
	Instructions Cut eggplant into small slices and sprinkle with 1 tablespoon lemon juice. Let stand for 3 minutes.		

(continued)

Food	Serving Size	Power	Time (min.)
Leeks	0.6 lbs.	100 %	3½-4
	Instructions Cut leeks into thick slices. Let stand for 3 minutes.		
Mushrooms	0.25 lbs. 0.6 lbs.	100 %	1½-2 2½-3
	Instructions Prepare small whole or sliced mushrooms. Do not add any water. Sprinkle with lemon juice. Spice with salt and pepper. Drain before serving. Let stand for 3 minutes.		
Onions	0.6 lbs.	100 %	5-5½
	Instructions Cut onions into slices or halves. Add only 15 ml (1 tbsp.) water. Let stand for 3 minutes.		
Pepper	0.6 lbs.	100 %	4½-5
	Instructions Cut pepper into small slices. Let stand for 3 minutes.		
Potatoes	0.6 lbs. 1.0 lbs.	100 %	4-5 7-8
	Instructions Weigh the peeled potatoes and cut them into similar sized halves or quarters. Let stand for 3 minutes.		
Turnip Cabbage	0.6 lbs.	100 %	5½-6
	Instructions Cut turnip into small cubes. Let stand for 3 minutes.		

Cooking guide for rice and pasta

- Rice:** Use a large glass pyrex bowl with lid - rice doubles in volume during cooking. Cook covered.
After the cooking time is over, stir before standing time and salt or add herbs and butter.
Remark: The rice may not have absorbed all water after the cooking time is finished.
- Pasta:** Use a large glass pyrex bowl. Add boiling water, a pinch of salt and stir well. Cook uncovered.
Stir occasionally during and after cooking. Cover during standing time and drain thoroughly afterwards.

Food	Serving Size	Power	Time (min.)
White Rice (Parboiled)	1 cup	80 %	15-16
	Instructions Add 2 cups of cold water for 1 cup of rice. Let stand for 5 minutes.		
	1½ cups	80 %	17½-18½
Brown Rice (Parboiled)	1 cup	80 %	20-21
	Instructions Add 2 cups of cold water for 1 cup of rice. Let stand for 5 minutes.		
	1½ cups	80 %	22-23
Mixed Rice (Rice + Wild Rice)	1 cup	80 %	16-17
	Instructions Add 2 cups of cold water for 1 cup of rice/wild rice mix. Let stand for 5 minutes. Let stand for 5 minutes.		
	1 cup	80 %	17-18
Pasta	1 cup	80 %	10-11
	Instructions Add 4 ¼ cups of water. Let stand for 5 minutes.		

REHEATING

Your microwave oven will reheat food in a fraction of the time that conventional ovens normally take.

Use the power levels and reheating times in the following chart as a guide. The times in the chart consider liquids with a room temperature of about 65-68 °F or a chilled food with a temperature of about 41-45 °F.

Arranging and covering

Avoid reheating large items such as joint of meat - they tend to overcook and dry out before the center is piping hot. Reheating small pieces will be more successful.

Power levels and stirring

Some foods can be reheated using 90 % power while others should be reheated using 60 %, 50 %, or even 30 %.

Check the tables for guidance.

In general, it is better to reheat food using a lower power level, if the food is delicate, in large quantities, or if it is likely to heat up very quickly (mince pies, for example).

Stir well or turn food over during reheating for best results. When possible, stir again before serving.

Take particular care when heating liquids and baby foods. To prevent eruptive boiling of liquids and possible scalding, stir, before, during, and after heating. Keep them in the microwave oven during standing time. We recommend putting a plastic spoon or glass stick into the liquids. Avoid overheating (and therefore spoiling) the food.

It is preferable to underestimate cooking time and add extra heating time, if necessary.

Heating and standing times

When reheating food for the first time, it is helpful to make a note of the time taken for future reference.

Always make sure that the reheated food is piping hot throughout.

Allow food to stand for a short time after reheating to let the temperature even out.

The recommended standing time after reheating is 2-4 minutes, unless another time is recommended in the chart.

Take particular care when heating liquids and baby food. See also the chapter with the safety precautions.

REHEATING LIQUIDS

Always allow a standing time of at least 20 seconds after the oven has been switched off to allow the temperature to even out. Stir during heating, if necessary, and ALWAYS stir after heating. To prevent eruptive boiling and possible scalding, you should put a spoon or glass stick into the beverages and stir before, during, and after heating.

REHEATING BABY FOOD

BABY FOOD: Empty into a deep ceramic plate. Cover with plastic lid. Stir well after reheating! Let stand for 2-3 minutes before serving. Stir again and check the temperature. Recommended serving temperature: between 86-104 °F.

BABY MILK: Pour milk into a sterilised glass bottle. Reheat uncovered. Never heat a baby's bottle with nipple on, as the bottle may explode if overheated. Shake well before standing time and again before serving ! Always carefully check the temperature of baby milk or food before giving it to the baby. Recommended serving temperature: ca. 99 °F.

REMARK:

Baby food in particular needs to be checked carefully before serving to prevent burns. Use the power levels and times in the table below as guides for reheating.

Reheating Liquids and Food

Use the power levels and times in this table as guidelines for reheating.

Food	Serving Size	Power	Time (min.)
Drinks (Coffee, Tea and Water)	150 ml (1 cup)	100 %	½-1
	300 ml (2 cups)		1½-2
450 ml (3 cups)	2½-3		
600 ml (4 cups)	3-3½		
Instructions			
Pour into cups and reheat uncovered: 1 cup in the center, 2 cups opposite of each other, 3 cups in a circle. Keep in microwave oven during standing time and stir well. Let stand for 1-2 minutes.			
Soup (Chilled)	0.6 lbs.	80 %	3½-4
	0.8 lbs.		4-4½
	1 lb.		4½-5
	1.2 lbs.		5½-6
Instructions			
Pour into a deep ceramic plate or deep ceramic bowl. Cover with a plastic lid. Stir well after reheating. Stir again before serving. Let stand for 2-3 minutes.			

(continued)

Food	Serving Size	Power	Time (min.)
Stew (Chilled)	0.8 lbs.	60 %	4½-5½
	Instructions Put stew in a deep ceramic plate. Cover with a plastic lid. Stir occasionally during reheating and again before standing and serving. Let stand for 2-3 minutes.		
Pasta with Sauce (Chilled)	0.8 lbs.	60 %	3½-4½
	Instructions Put pasta (e.g. spaghetti or egg noodles) on a flat ceramic plate. Cover with microwave cling film. Stir before serving. Let stand for 3 minutes.		
Filled Pasta with Sauce (Chilled)	0.8 lbs.	60 %	4-5
	Instructions Put filled pasta (e.g. ravioli, tortellini) in a deep ceramic plate. Cover with a plastic lid. Stir occasionally during reheating and again before standing and serving. Let stand for 3 minutes.		
Plated Meal (Chilled)	0.8 lbs.	60 %	4½-5½
	1.0 lb.		5½-6½
	1.2 lbs.		6½-7½
Instructions Plate a meal of 2-3 chilled components on a ceramic dish. Cover with microwave cling-film. Let stand for 3 minutes.			
Cheese Fondue Ready-to-Serve (Chilled)	0.9 lbs.	60 %	6-7
	Instructions Put the ready-to-serve cheese fondue in a suitable sized glass pyrex bowl with lid. Stir occasionally during and after reheating. Stir well before serving. Let stand for 1-2 minutes.		

Reheating baby food and milk

Use the power levels and times in this table as guides for reheating.

Food	Serving Size	Power	Time
Baby Food (Vegetables + Meat)	0.4 lbs.	60 %	30 sec.
	Instructions Empty into ceramic deep plate. Cook covered. Stir after cooking time. Before serving, stir well and check the temperature carefully. Let stand for 2-3 minutes.		
Baby Porridge (Grain + Milk + Fruit)	0.4 lbs.	60 %	20 sec.
	Instructions Empty into ceramic deep plate. Cook covered. Stir after cooking time. Before serving, stir well and check the temperature carefully. Let stand for 2-3 minutes.		
Baby Milk	100 ml	30 %	30-40 sec.
	200 ml		1 min. to 1 min. 10 sec.
	Instructions Stir or shake well and pour into a sterilized glass bottle. Place in the center of turntable. Cook uncovered. Shake well and let stand for at least 3 minutes. Before serving, shake well and check the temperature carefully. Let stand for 2-3 minutes.		

DEFROSTING

Microwaves are an excellent way of defrosting frozen food. Microwaves gently defrost frozen food in a short period of time. This can be of great advantage, if unexpected guests suddenly show up.

Frozen poultry must be thoroughly thawed before cooking. Remove any metal ties and take it out of any wrapping to allow thawed liquid to drain away.

Put the frozen food on a dish without cover. Turn over half way, drain off any liquid, and, if you are defrosting chicken, remove any giblets as soon as possible. Check the food occasionally to make sure that it does not feel warm.

If smaller and thinner parts of the frozen food start to warm up, shield the parts by wrapping small strips of aluminium foil around them during defrosting.

Should poultry start to warm up on the outer surface, stop thawing and allow it to stand for 20 minutes before continuing. Let fish, meat, and poultry stand to complete defrosting. The standing time for complete defrosting will vary depending on the quantity defrosted. Please refer to the table below.

Hint: Thin food defrosts better than thick food and smaller quantities need less time than larger quantities.

To defrost frozen food with a temperature of about -5 to -4 °F, use the following table as a guide.

Food	Serving Size	Power	Time (min.)
Meat			
Minced Beef	0.6 lbs. 1.1 lbs.	20 %	6-7 8-13
Pork Steaks	0.6 lbs.	20 %	7-8
	Instructions Place the meat on the turntable. Shield thinner edges with aluminium foil. Turn over after half of defrosting time! Let stand for 15-30 minutes.		

Food	Serving Size	Power	Time (min.)
Poultry			
Chicken Pieces	1.1 lbs. (2 pcs)	20 %	14-15
Whole Chicken	2.7 lbs	20 %	32-34
	Instructions First, put chicken pieces first skin-side down, whole chicken first breast-side-down on a flat ceramic plate. Shield the thinner parts like wings and ends with aluminium foil. Turn over after half of defrosting time! Let stand for 15-60 minutes.		
Fish			
Fish Fillets	0.4 lbs.	20 %	6-7
Whole fish	0.9 lbs.	20 %	11-13
	Instructions Put frozen fish in the middle of a flat ceramic plate. Arrange the thinner parts under the thicker parts. Shield narrow ends of fillets and tail of whole fish with aluminium foil. Turn over after half of defrosting time! Let stand for 10-25 minutes.		
Fruits			
Berries	0.7 lbs.	20 %	6-7
	Instructions Spread fruit on a flat, round glass dish (with a large diameter). Let stand for 5-10 minutes.		
Bread			
Bread Rolls (Each ca. 50 g)	2 pcs 4 pcs	20 %	1-1½ 2½-3
Toast/Sandwich	0.6 lbs.	20 %	4-4½
German Bread (Wheat + Rye Flour)	1.1 lbs.	20 %	7-9
	Instructions Arrange rolls in a circle or bread horizontally on kitchen paper in the middle of turntable. Turn over after half of defrosting time! Let stand for 5-20 minutes.		

GRILL

The grill-heating element is located underneath the ceiling of the cavity. It operates while the door is closed and the turntable is rotating. The turntable's rotation makes the food brown more evenly. Preheating the grill for 3-5 minutes will make the food brown more quickly.

Cookware for grilling:

Should be flameproof and may include metal. Do not use any type of plastic cookware, as it can melt.

Food suitable for grilling:

Chops, sausages, steaks, hamburgers, bacon and gammon rashers, thin fish portions, sandwiches, and all kinds of toast with toppings.

Important remark:

Whenever you use the grill only mode, please remember that food must be placed on the high rack, you are instructed otherwise.

MICROWAVE + GRILL

This cooking mode combines the radiant heat that is coming from the grill with the speed of microwave cooking. It operates only while the door is closed and the turntable is rotating. Due to the rotation of the turntable, the food browns evenly. The combination mode is available with this model: 30 % + Grill.

Cookware for cooking with microwave + grill

Please use cookware that microwaves can pass through. Cookware should be flameproof. Do not use metal cookware with combination mode. Do not use any type of plastic cookware, as it can melt.

Food suitable for microwave + grill cooking:

Food suitable for combination mode cooking include all kinds of cooked food which need reheating and browning (e.g. baked pasta), as well as foods which require a short cooking time to brown the top of the food. Also, this mode can be used for thick food portions that benefit from a browned and crispy top (e.g. chicken pieces, turning them over half way through cooking). Please refer to the grill table for further details.

Important remark:

Whenever you use the combination mode (microwave + grill), the food should be placed on the high rack, you are instructed otherwise. Please refer to the instructions in the following chart.

The food must be turned over, if it is to be browned on both sides.

Grill Guide for fresh food

Preheat the grill with the grill-function for 2-3 minutes.

Use the power levels and times in this table as guides for grilling.

Use oven gloves when taking the food out of the microwave.

Fresh Food	Serving Size	Power	1 step (min.)	2 step (min.)
Toast Slices	4 pcs (each 25 g)	Grill only	3-4	2-3
	Instructions Put toast slices side by side on the high rack.			
Grilled Tomatoes	0.9 lbs. (2 pcs)	30 % + Grill	6-8	-
	Instructions Cut tomatoes into halves. Put some cheese on top. Arrange in a circle in a flat glass pyrex dish. Place it on the high rack. Let stand for 2-3 minutes.			
Tomato-Cheese Toast	4 pcs (0.7 lbs.)	30 % + Grill	5-7	-
	Instructions Toast the bread slices first. Put the toast with topping on the high rack. Let stand for 2-3 minutes.			
Toast Hawaii (Ham, Pineapple, Cheese Slices)	4 pcs (1.1 lbs.)	30 % + Grill	6-8	-
	Instructions Toast the bread slices first. Put the toast with topping on the high rack. Let stand for 2-3 minutes.			
Baked Potatoes	1.1 lbs.	30 % + Grill	8-10	-
	Instructions Cut potatoes into halves. Put them in a circle on the high rack with the cut side to the grill.			
Gratin Potatoes/Vegetables (Chilled)	1 lb.	30 % + Grill	10-12	-
	Instructions Put the fresh gratin into a small glass pyrex dish. Put the dish on the high rack. After cooking, let stand for 2-3 minutes.			

Fresh Food	Serving Size	Power	1 step (min.)	2 step (min.)
Baked Apples	2 apples (ca. 0.9 lbs.)	30 % + Grill	7-8	-
	Instructions Core the apples and fill them with raisins and jam. Put some almond slices on top. Put apples on a flat glass pyrex dish. Place the dish directly on the low rack.			
Chicken Pieces	1.1 lbs. (2 pcs)	30 % + Grill	8-10	6-8
	Instructions Brush chicken pieces with oil and spices. Put them in a circle on the high rack. After grilling, let stand for 2-3 minutes.			
Roast Chicken	2.7 lbs.	30 % + Grill	21-23	20-22
	Instructions Brush the chicken oil and spices. Put breast-side-down, in the middle of the low rack. After grilling, let stand for 5 minutes.			
Roast Fish	0.9-1.1 lbs.	30 % + Grill	6-8	6-7
	Instructions Brush skin of whole fish with oil and add herbs and spices. Put two fish side by side (head to tail) on the high rack. After grilling, let stand for 2-3 minutes.			

CONVECTION

Cooking with convection is the traditional and well-known method of cooking food in a traditional oven with hot air.

The heating element and the fan position is at the back-wall, so that the hot air circulates. This mode is supported by the top heating element.

Cookware for convection cooking:

All conventional ovenproof cookware, baking tins and sheets – anything you would normally use in a traditional convection oven – can be used.

Food suitable for convection cooking:

All biscuits, individual scones, rolls and cakes should be cooked using this mode as well as rich fruit cakes, choux pastry, and soufflés.

MICROWAVE + CONVECTION

This mode combines microwave energy with the hot air. It reduces cooking time while giving food a brown and crispy surface.

Cookware for cooking with microwaves + convection:

Cookware should be ovenproof (glass, ceramic, potter, or china without metal trim) and be able to let microwaves pass through, similar to the cookware described under Microwave + Grill.

Food suitable for Microwave + Convection cooking:

All kinds of meat and poultry as well as casseroles and gratin dishes, sponge cakes and light fruit cakes, pies and crumbles, roast vegetables, scones and breads.

Convection Guide for fresh and frozen food

Preheat with the auto pre-heat function to the desired temperature. Use the power levels and times in this table as guides for convection cooking. Use oven gloves when taking the food out of the microwave.

Fresh Food	Serving Size	Power	1 step (min.)	2 step (min.)
Pizza Frozen Pizza (Ready Baked)	0.7-0.9 lbs.	1 step 30 % + 400 °F 2 step Conv. 350 °F	7-9	5-6
Instructions Place the pizza on the low rack. After baking, let stand for 2-3 minutes.				
Pasta Frozen Lasagne	0.9 lbs.	1 step 30 % + 400 °F 2 step Conv. 400 °F	16-18	3-4
Instructions Put into a suitable sized glass pyrex dish or leave in the original packaging (take care that this is suitable for microwaves and oven heat). Put frozen pasta gratin on the low rack. After cooking, let stand for 2-3 minutes.				
Meat Roast Beef/ Roast Lamb (Medium)	2.7-2.9 lbs.	30 % + 350 °F	22-25	12-14
Instructions Brush beef/ lamb with oil and spice it with pepper, salt and paprika. Put it on the low rack, first with the fat side down. After cooking, wrap in aluminium foil and let stand for 10-15 minutes.				
Roast Chicken	2.2-2.7 lbs.	1 step 30 % + 400 °F 2 step 30 % + Grill	22-24	22-24
Instructions Brush chicken with oil and spices. For the first step, put the chicken breast side down on the low rack. For the second step, turn the chicken breast side up. Let stand for 5 minutes.				

Fresh Food	Serving Size	Power	1 step (min.)	2 step (min.)
Bread Fresh Bread Rolls	6 pcs (0.8 lbs.)	30 % + 350 °F	7-9	-
Instructions Put bread rolls in a circle on the low rack. Let stand for 2-3 minutes.				
Garlic Bread (Chilled, Prebaked)	0.45 lbs. (1 pc)	30 % + 400 °F	7-9	-
Instructions Put the chilled baguette on baking paper on the low rack. After baking, let stand for 2-3 minutes.				
Cake Marble Cake (Fresh Dough)	1.1 lbs.	Only 350 °F	38-43	-
Instructions Put the fresh dough in a small rectangular black metal baking dish (length 25 cm). Put the cake on the low rack. After baking, let stand for 5-10 minutes.				
Small Cakes (Fresh Dough)	12 x 0.06 lbs.	Only 325 °F	28-33	-
Instructions Fill the fresh dough evenly in paper cups and set on crusty plate on the low rack. After baking, let stand for 5 minutes.				
Cookies (Fresh Dough)	0.45-0.6 lbs.	Only 400 °F	15-20	-
Instructions Put the chilled croissants on baking paper on the low rack.				
Frozen Cake	2.2 lbs.	30 % + 400 °F	15-19	-
Instructions Put the frozen cake directly on the low rack. After defrosting and warming, let stand 15-20 minutes.				

TIPS AND TRICKS

MELTING BUTTER

Put about 3 tablespoons butter into a small deep glass dish. Cover with plastic lid. Heat for 30-40 seconds using 90 %, until butter is melted.

MELTING CHOCOLATE

Put about a half cup (¼ lbs) chocolate into a small deep glass dish. Heat for 3-5 minutes, using 50 % until chocolate is melted. Stir once or twice during melting. Use oven gloves while taking out!

MELTING CRYSTALLIZED HONEY

Put ¼ oz (20 g) crystallized honey into a small deep glass dish. Heat for 20-30 seconds using 30 %, until honey is melted.

MELTING GELATINE

Lay dry gelatine sheets ½ oz (10 g) for 5 minutes in cold water. Put drained gelatine into a small glass pyrex bowl. Heat for 1 minute using 30 %. Stir after melting.

COOKING GLAZE/ICING (FOR CAKE AND GATEAUX)

Mix instant glaze (approximately 3 teaspoons) with 2½ tablespoons (40 g) sugar and 1 cup (250 ml) cold water. Cook uncovered in a glass pyrex bowl for 3½ to 4½ minutes using 90 %, until glaze/icing is transparent. Stir twice during cooking.

COOKING JAM

Put 21 oz of fruit (600 g or about 2½ cups) (for example mixed berries) in a suitable sized glass pyrex bowl with lid. Add 1½ cups (300 g) preserving sugar and stir well. Cook covered for 10-12 minutes using 90 %. Stir several times during cooking. Empty directly into small jam glasses with twist-off lids. Let stand with the lid on for 5 minutes.

COOKING PUDDING

Mix the pudding mix with milk following the manufacturer's instructions. Add sugar if instructed. Stir well. Use a suitable sized glass pyrex bowl with lid. Cook covered for 6½ to 7½ minutes using 90 %. Stir several times well during cooking.

BROWNING ALMOND SLICES

Spread about 1 oz (30 g) of sliced almonds evenly on a medium sized ceramic plate. Stir several times during browning for 3½ to 4½ minutes using 60 %. Let it stand for 2-3 minutes in the oven. Use oven gloves when taking out!

troubleshooting and error codes

Becoming familiar with a new appliance always takes a little time. If you have any of the problems listed below, try the solutions given. They may save you the time and inconvenience of an unnecessary service call.

TROUBLESHOOTING

Check these solutions if you have a problem with your microwave:

The display and/or the oven is not working.

Make sure the plug is properly connected to a grounded outlet. If the wall outlet is controlled by a wall switch, make sure the wall switch is turned on. Remove the plug from the outlet, wait ten seconds, and plug it in again.

Reset the circuit breaker or replace any blown fuses.

Plug a different appliance into the outlet. If the other appliance doesn't work, call a qualified electrician to repair the wall outlet. Plug the oven into a different outlet.

The display is working, but the power won't come on

Make sure the door is closed securely.

Check if any packaging material or anything else is stuck in the door seal.

Check if the door is damaged.

Touch Cancel twice, and enter all the cooking instructions again.

The microwave turned off before the set time elapsed.

If there was a power outage, the time indicator will display: 88:88.

If no power outage occurred, remove the plug from the outlet, wait ten seconds, and plug it in again. Reset the clock and any cooking instructions.

Reset the circuit breaker or replace any blown fuses.

Cooks food too slowly.

Make sure the oven has its own 20 amp circuit line. Operating another appliance on the same circuit can cause a voltage drop. If necessary, move the oven to its own circuit.

Has sparks or arcing.

Remove any metallic utensils, cookware, or metal ties. If using foil, use only narrow strips and allow at least one inch between the foil and the interior oven walls.

The turntable makes noise or becomes stuck.

Clean the turntable, roller ring, and oven floor.

Make sure the turntable and roller ring are positioned correctly.

Causes TV or radio interference.

This is similar to interference caused by other small appliances, such as hair dryers. Move your microwave (or appliance) away from your TV or radio.

Operating noise is too loud.

The MWO makes noise during operation. This is normal.

If you hear an abnormal sound continuously, please contact the Samsung Call Center (1-800-SAMSUNG (726-7864)).

Turntable rotates improperly.

Make sure you have not put too much food on the turntable.

If the food is too large or too heavy, the turntable may operate improperly.

Smoke and bad smell when initial operating.

It's a temporary condition by new component heating. Smoke and smell will disappear completely after 10 minutes operation. To remove smell more quickly, please operate microwave oven with putting lemon formation or lemon juice in the cabinet.

 If the above guidelines do not enable you to solve the problem, then contact your local SAMSUNG customer service center.

Please have the following information available:

- The model and serial numbers, normally printed on the rear of the oven
- Your warranty details
- A clear description of the problem

 If you set the power level to more than 70 %, the microwave will automatically decrease the power level to 70 % after 20 minutes to prevent overcooking.

ERROR CODE

The SE Error Message

- The "SE" message indicates a "Key Short" error.
Check if one or more buttons is stuck in the "pressed" or "On" position. If that is not the case, turn off the microwave oven and try setting it again.
If the SE error recurs, call your local SAMSUNG Customer Care Center.

WARRANTY AND SERVICE INFORMATION

To help us to serve you better, please complete the enclosed registration card and promptly return it by mail. If the registration card is missing, you can call Samsung Electronics, Inc., at

1-800-SAMSUNG (726-7864) or register online at www.samsung.com/register.

When contacting Samsung, please provide the specific model and serial number information which is usually located on the back or bottom of the product. Please record these numbers in the spaces provided below, along with the other requested information. Keep this information in a safe place as a permanent record of your purchase to aid in identification in case of theft or loss. Also keep a copy of your sales receipt as a proof of purchase if warranty service is needed.

MODEL NUMBER _____

SERIAL NUMBER _____

DATE PURCHASED _____

PURCHASED FROM _____

Warranty service can only be performed by a Samsung Authorized Service Center. If you should require warranty service, provide the above information with a copy of your sales receipt to the Samsung Authorized Service Center.

For service assistance and the location of the nearest service center, please call **1-800-SAMSUNG (726-7864)**.

technical specifications

SAMSUNG strives to improve its products at all times. Both the design specifications and these user instructions are thus subject to change without notice.

Model	MC11H6033CT
Power source	120 V ~ 60 Hz
Power consumption	
Microwave	1600 W
Grill	1300 W
Convection	1750 W
Combined mode	1750 W
Output power	100 W / 1000 W (IEC-705)
Operating frequency	2450 MHz
Magnetron	OM75P (31)
Cooling method	Cooling fan motor
Dimensions (W x H x D)	
Outside	20 ⁹ / ₁₆ " x 12 ³ / ₁₆ " x 19 ¹⁵ / ₁₆ "
Oven cavity	14 ¹¹ / ₁₆ " x 9 ¹ / ₈ " x 14 ⁹ / ₁₆ "
Volume	1.1 cu.ft
Weight	
Net/Gross	44.1lbs / 50.7lbs

warranty

SAMSUNG MICROWAVE OVEN

Limited warranty to original purchaser

This SAMSUNG brand product, as supplied and distributed by Samsung Electronics America, Inc. (SAMSUNG) and delivered new, in the original carton to the original consumer purchaser, is warranted by SAMSUNG against manufacturing defects in materials and workmanship for a limited warranty period of:

ONE (1) YEAR PARTS AND LABOR, TEN (10) YEARS PARTS WARRANTY FOR MAGNETRON

Samsung will charge a repair fee for replacing an accessory or repairing a cosmetic defect if the damage to the unit and/or damage to or loss of the accessory was caused by the customer. Items this stipulation covers include:

- A Dented, Scratched, or Broken Door, Handle, Out-Panel, or Control Panel
- A Broken or missing Tray, Guide Roller, Coupler, Filter, or Wire Rack

User Replaceable Parts may be sent to the customer for unit repair. If necessary, a Service Engineer can be dispatched to perform service.

This limited warranty begins on the original date of purchase, and is valid only on products purchased and used in the United States. To receive warranty service, the purchaser must contact SAMSUNG for problem determination and service procedures. Warranty service can only be performed by a SAMSUNG authorized service center. The original dated bill of sale must be presented upon request as proof of purchase to SAMSUNG or SAMSUNG's authorized service center.

SAMSUNG will repair or replace this product, at our option and at no charge as stipulated herein, with new or reconditioned parts or products if found to be defective during the limited warranty period specified above. All replaced parts and products become the property of SAMSUNG and must be returned to SAMSUNG. Replacement parts and products assume the remaining original warranty, or ninety (90) days, whichever is longer.

In-home service will be provided during the warranty labor period subject to availability within the contiguous United States. In-home service is not available in all areas. To receive in-home service, the product must be unobstructed and accessible to service personnel. If during in-home service repair can not be completed, it may be necessary to remove, repair and return the product. If in-home service is unavailable, SAMSUNG may elect, at our option, to provide for transportation of our choice to and from a SAMSUNG authorized service center. Otherwise, transportation to and from the SAMSUNG authorized service center is the responsibility of the purchaser.

This limited warranty covers manufacturing defects in materials and workmanship encountered in normal, noncommercial use of this product and shall not apply to the following, including, but not limited to: damage which occurs in shipment; delivery and installation; applications and uses for which this product was not intended; altered product or serial numbers; cosmetic damage or exterior finish; accidents, abuse, neglect, fire, water, lightning or other acts of nature; use of products, equipment, systems, utilities, services, parts, supplies, accessories, applications, installations, repairs, external wiring or connectors not supplied or authorized by SAMSUNG which damage this product or result in service problems; incorrect electrical line voltage, fluctuations and surges; customer adjustments and failure to follow operating instructions, cleaning, maintenance and environmental instructions that are covered and prescribed in the instruction book; problems caused by pest infestations, and overheating or overcooking by user; glass tray or turntable; reduced magnetron power output related to normal aging. SAMSUNG does not warrant uninterrupted or error-free operation of the product.

THERE ARE NO EXPRESS WARRANTIES OTHER THAN THOSE LISTED AND DESCRIBED ABOVE, AND NO WARRANTIES WHETHER EXPRESS OR IMPLIED, INCLUDING, BUT NOT LIMITED TO, ANY IMPLIED WARRANTIES OF MERCHANTABILITY OR FITNESS FOR A PARTICULAR PURPOSE, SHALL APPLY AFTER THE EXPRESS WARRANTY PERIODS STATED ABOVE, AND NO OTHER EXPRESS WARRANTY OR GUARANTY GIVEN BY ANY PERSON, FIRM OR CORPORATION WITH RESPECT TO THIS PRODUCT SHALL BE BINDING ON SAMSUNG. SAMSUNG SHALL NOT BE LIABLE FOR LOSS OF REVENUE OR PROFITS, FAILURE TO REALIZE SAVINGS OR OTHER BENEFITS, OR ANY OTHER SPECIAL, INCIDENTAL OR CONSEQUENTIAL DAMAGES CAUSED BY THE USE, MISUSE OR INABILITY TO USE THIS PRODUCT, REGARDLESS OF THE LEGAL THEORY ON WHICH THE CLAIM IS BASED, AND EVEN IF SAMSUNG HAS BEEN ADVISED OF THE POSSIBILITY OF SUCH DAMAGES. NOR SHALL RECOVERY OF ANY KIND AGAINST SAMSUNG BE GREATER IN AMOUNT THAN THE PURCHASE PRICE OF THE PRODUCT SOLD BY SAMSUNG AND CAUSING THE ALLEGED DAMAGE. WITHOUT LIMITING THE FOREGOING, PURCHASER ASSUMES ALL RISK AND LIABILITY FOR LOSS, DAMAGE OR INJURY TO PURCHASER AND PURCHASER'S PROPERTY AND TO OTHERS AND THEIR PROPERTY ARISING OUT OF THE USE, MISUSE OR INABILITY TO USE THIS PRODUCT SOLD BY SAMSUNG NOT CAUSED DIRECTLY BY THE NEGLIGENCE OF SAMSUNG. THIS LIMITED WARRANTY SHALL NOT EXTEND TO ANYONE OTHER THAN THE ORIGINAL PURCHASER OF THIS PRODUCT, IS NONTRANSFERABLE AND STATES YOUR EXCLUSIVE REMEDY.

Some provinces or territories may or may not allow limitations on how long an implied warranty lasts, or the exclusion or limitation of incidental or consequential damages, so the above limitations or exclusions may not apply to you. This warranty gives you specific legal rights, and you may also have other rights which vary from state to state.

To obtain warranty service, please contact SAMSUNG at:

▪ **1-800-SAMSUNG (726-7864) or www.samsung.com/us/support**

MEMO

MEMO

SAMSUNG



Scan the QR code* or visit
www.samsung.com/spsn
to view our helpful
How-to Videos and Live Shows

*Requires reader to be installed on your smartphone

Scan this with your smartphone

Please be advised that the Samsung warranty does NOT cover service calls to explain product operation, correct improper installation, or perform normal cleaning or maintenance.

QUESTIONS OR COMMENTS?

COUNTRY	CALL	OR VISIT US ONLINE AT
U.S.A Consumer Electronics	1-800-SAMSUNG (726-7864)	www.samsung.com/us/support
CANADA	1-800-SAMSUNG (726-7864)	www.samsung.com/ca/support (English) www.samsung.com/ca_fr/support (French)