

Installation Instructions

Automatic Icemaker

ZDIC150

ZDIS150

Design Guide

With Installation Instructions



Installation Instructions

- **BEFORE YOU BEGIN:**

Read these instructions completely and carefully.

- **IMPORTANT:**

Save these instructions for local inspector's use.

- **IMPORTANT:**

Observe all governing codes and ordinances.

- **Note to Installer** – Be sure to leave these instructions with the Consumer.

- **Note to Consumer** – Keep these instructions with your Owner's Manual for future reference.



WARNING:

This appliance must be properly grounded. Failure to do so can result in death, fire or electrical shock. See "Power Supply," page 5.



AVERTISSEMENT :

Cet appareil doit être correctement mis à la terre. Le non-respect de ces instructions peut causer la mort, un incendie ou un choc électrique. Consulter « Alimentation électrique », page 5.

If you received a damaged icemaker, you should immediately contact your dealer or builder.

Proper installation is the responsibility of the installer. Product failure due to improper installation is not covered under the GE Appliance Warranty. See the Owner's Manual for warranty information.

- Use this appliance only for its intended purpose.

Check with local utilities for electrical codes that apply in your area. Local codes vary. Installation, electrical connections and grounding must comply with applicable codes. In the absence of local codes, the icemaker should be installed in accordance with National Electrical Code ANSI/NFPA 70-1990 or latest edition.

For Monogram local service in your area, call 1.800.444.1845.

For Monogram Service in Canada, call 1.800.561.3344.

For Monogram Parts and Accessories, call 1.800.626.2002.

CONTENTS

Design Information

| | |
|------------------------------------|---|
| Models Available | 3 |
| Cutout & Product Dimensions | 3 |
| Optional Accessories | 3 |
| Tools and Materials Required | 3 |

Installation

| | |
|---------------------------------|------|
| Advance Planning | 4 |
| Power Supply | 5 |
| Remove Packaging | 5 |
| Adjust Height of Icemaker | 5 |
| Water Supply | 6 |
| Connect the Drain | 6 |
| Connect Water Supply | 7 |
| Reverse Door Swing | 7, 8 |

Accessories

| | |
|--------------------------------------------------|-------|
| ZIP75WW, ZIP75BB Kit for 3/4" thick panels | 9, 10 |
| ZTBSS1 Tubular Handle Kit | 11 |

Design Information

MODELS AVAILABLE

ZDIC150, ZDIS150
Available in black, white and stainless steel.

The icemaker may be installed below a countertop or used free-standing.

CUTOUT & PRODUCT DIMENSIONS

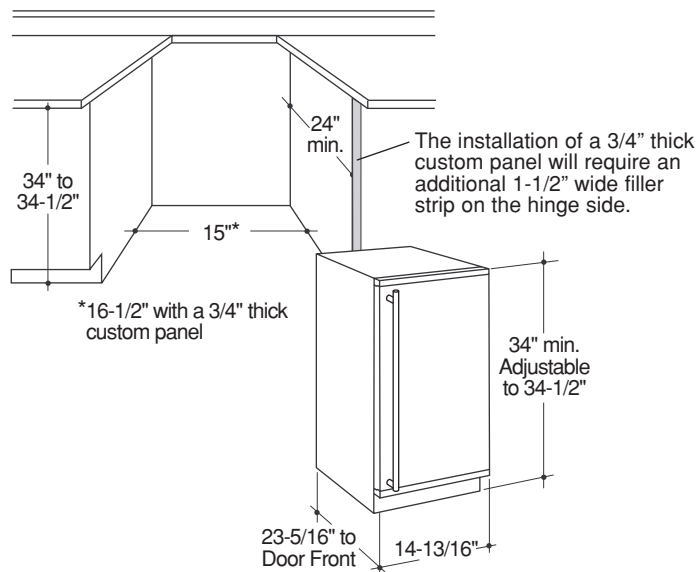

Cutout dimensions shown allow for a full door swing.

Additional Clearances:

- The installation of a 3/4" thick custom panel will require an additional 1-1/2" wide filler strip on the hinge side. The filler strip will act as a spacer between the icemaker case and an adjacent cabinet. The filler strip will prevent interference with the icemaker door swing when it is installed between frameless or framed cabinetry. The width of the opening must include the filler strip.

NOTE: The addition of a 3/4" thick front panel will result in a front to back depth of 24-1/16". The product cannot be installed flush to adjacent 24" deep cabinets with a 3/4" thick custom panel.

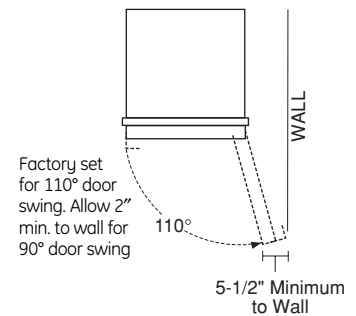

OPTIONAL ACCESSORIES

ZIP75WW White and ZIP75BB Black—For the installation of a trimless 3/4" thick custom panel on white and black models (not for stainless steel models). This kit provides a handle that can be installed with the custom panel. A custom handle of your choice may be installed onto the 3/4" panel. See installation instructions on pages 9 and 10.

ZTBS1—Monogram tubular stainless steel handle for 3/4" thick custom panels. Order this kit from your Monogram supplier.

ZPK1—Drain Pump Kit. For use when a floor drain is not available. The drain pump must be installed inside the unit and can operate at a maximum vertical height of 10 feet. 10 feet of tubing is supplied with the kit.

TOOLS AND MATERIALS REQUIRED

- 1/4" socket
- 3/4" adjustable wrench
- Level
- GE SmartConnect™ Refrigerator Tubing Kit or 1/4" O.D. copper tubing, of sufficient length to reach the installation

Installation Instructions

ADVANCE PLANNING



CAUTION: Due to excessive weight, TWO PEOPLE ARE REQUIRED TO MOVE AND INSTALL THIS ICEMAKER. Failure to do so can result in back or other injury.



MISE EN GARDE :
A cause de son poids élevé, IL FAUT DEUX PERSONNES POUR DÉPLACER ET INSTALLER CETTE MACHINE À GLAÇONS. Le non-respect de ces instructions peut causer des blessures au dos ou d'autre nature.

WATER SUPPLY

A cold water supply with water pressure of between 30 and 120 psi is required to operate the icemaker. If you have questions about your water pressure, call a licensed, qualified plumber.

REVERSE OSMOSIS WATER SUPPLY

IMPORTANT: The performance of the icemaker may be affected when it is connected to a reverse osmosis system.

- The pressure of the water supply coming out of a reverse osmosis system going to the water inlet valve of the icemaker needs to be between 30 and 120 psi.
- If a reverse osmosis water filtration system is connected to your cold water supply, the water pressure to the reverse osmosis system needs to be a minimum of 40 to 60 psi. The reverse osmosis system must provide 1 gal. of water per hour to the icemaker for proper icemaker operation.
- **Do not use copper tubing when the icemaker is connected to a reverse osmosis water system.**

Choose the location:

- Not designed for outdoor installation.
- The icemaker must be installed in an area protected from elements such as wind, rain, water spray or drip. The area should be ventilated with temperatures above 55°F (13°C) and below 110°F (43°C). Best results are obtained between 70°F (21°C) and 90°F (32°C).
- The icemaker may be closed in on the top and three sides as long as the front is unobstructed for air circulation and proper operation.
 - Installation should be such that the icemaker can be moved forward for servicing, if necessary.
 - The bottom grille on the front must be unobstructed to provide proper air flow.

ADVANCE PLANNING (cont.)

Before you begin:

1. If a custom panel is to be installed, follow the instructions shown on pages 9 and 10.
 - Order ZIP75 (black or white) panel kit.
 - Order the custom panel from the cabinet manufacturer.
 - Secure the custom panel onto the icemaker.
2. Determine a method of drainage. If a floor drain is to be installed, the drain must be accurately located. The installation of a custom door panel will affect the drain location. See page 6 to determine the exact location of the floor drain, front to back, with or without a custom door panel.
 - A drain pump kit, ZPK1, is available and will not interfere with placement of the icemaker.
3. The door swing is reversible. If desired, change the door swing before installation.
4. Slide the icemaker into the installation location.
 - Open and close the door to be sure there is no interference.
 - Check to be sure the icemaker can be moved back into the opening, flush with adjacent cabinetry. There should be no interference with the floor drain.
 - Check to be sure the icemaker is level. The icemaker will not operate properly if it is not level. See page 5.

Installation Instructions

POWER SUPPLY



WARNING: (Please read carefully). FOR PERSONAL SAFETY, THIS APPLIANCE MUST BE PROPERLY GROUNDED. Failure to follow these instructions can result in death, fire or electrical shock.



AVERTISSEMENT : (S'il vous lisez avec soin). POUR VOTRE SÉCURITÉ, CET APPAREIL DOIT ÊTRE CORRECTEMENT MIS À LA TERRE. Le non-respect de ces instructions peut causer la mort, un incendie ou un choc électrique.

Do not use an extension cord or adapter plug with this appliance. Follow National Electrical Code or prevailing local codes and ordinances.

This icemaker must be supplied with 115V, 60Hz, and connected to an individual, properly grounded branch circuit, and protected by a 15 or 20 amp circuit breaker or time delay fuse.

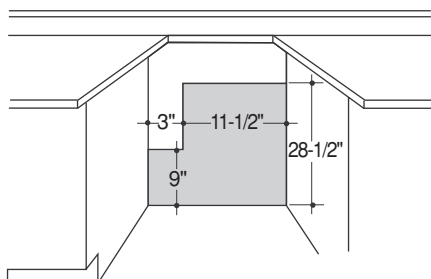

Electrical Supply Should Enter From Back Wall In Shaded Area.

- A properly grounded three-prong receptacle should be located within reach of the icemaker's 66" long power cord. For a built-in installation, locate the receptacle in the shaded area shown.

IMPORTANT: (Please read carefully).

The power cord of this appliance is equipped with a three-prong (grounding) plug that mates with a standard three-prong grounding wall receptacle to minimize the possibility of electric shock. The customer should have the wall receptacle and circuit checked by a qualified electrician to make sure the receptacle is properly grounded and has the correct polarity.

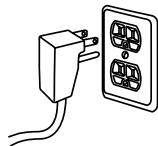

- Where a standard two-prong wall receptacle is encountered, it is the personal responsibility and obligation of the customer to have it replaced with a properly grounded three-prong wall receptacle.

Do not, under any circumstances, cut or remove the third (ground) prong from the power cord. DO NOT USE AN EXTENSION CORD.

REMOVE PACKAGING AND PARTS

- Lay the carton on rear face and break open the bottom flap.
- Set the carton upright with all four bottom flaps outward.
- Lift carton up and off icemaker.
- Remove all tape and packaging material from the outside and inside of the cabinet.

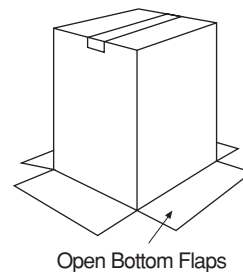

ADJUST HEIGHT AND LEVEL THE ICEMAKER

Height adjustments may be necessary to install the icemaker below a countertop, and may be accomplished by adjusting both the front and rear leveling legs. The icemaker must be level to operate properly.

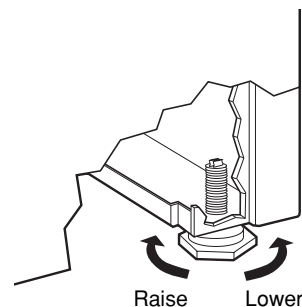

To level and adjust the height:

- With one person holding the icemaker, carefully tilt the machine to access the leveling legs.
- Use an adjustable wrench to turn the legs. -Turn legs right to lower, turn left to raise the icemaker.
- Check top and side with a level. Continue adjusting legs until the icemaker is level and stable.

Installation Instructions

WATER SUPPLY

- A cold water supply is required for icemaker operation. The water pressure must be between 30 and 120 p.s.i.

- Route GE SmartConnect™ Kit or 1/4" O.D. copper tubing between house cold water line and the water connection location.

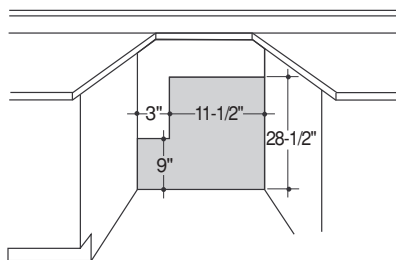

Water Supply Should Enter From Back Wall In Shaded Area.

- The water line should be long enough to extend to the back of the icemaker. Allow enough to accommodate moving unit forward for service.

NOTE: The only GE approved plastic tubing is supplied in the GE SmartConnect™ Refrigerator Tubing kits. Do not use any other plastic water supply line because the line is under pressure at all times. Other types of plastic may crack or rupture with age and cause water damage to your home. GE SmartConnect™ Refrigerator Tubing Kits are available in the following lengths:

2' (0.6 m) WX08X10002 15' (4.6 m) WX08X10015
6' (1.8 m) WX08X10006 25' (7.6 m) WX08X10025

Shut off the main water supply

Turn on the nearest faucet long enough to clear the line of water.

Install a shut-off valve between the icemaker water valve and cold water pipe in a basement or cabinet. The installation of an easily accessible shut-off valve in the water line is required.

NOTE: It is best to install the valve into a vertical water pipe. If you install the valve into a horizontal water pipe, make the connection at the top or side, rather than at the bottom, to avoid drawing off any sediment from the water pipe.

- Turn on the main water supply and flush debris from the line. Run about a quart of water through the tubing into a bucket. Shut off water supply at the shut-off valve.

NOTE: Saddle type shut-off valves are included in many water supply kits, but are not recommended for this application.

NOTE: Commonwealth of Massachusetts Plumbing Codes 248CMR shall be adhered to. Saddle valves are illegal and use is not permitted in Massachusetts. Consult with your licensed plumber.

- Install optional water filter in the water line near the icemaker. A water filter is recommended in areas where water supply contains sand or particles. Installation instructions are packed with the filter.

WATER SUPPLY (cont.)

REVERSE OSMOSIS WATER SUPPLY

IMPORTANT: The performance of the icemaker may be affected when it is connected to a reverse osmosis system.

- The pressure of the water supply coming out of a reverse osmosis system going to the water inlet valve of the icemaker needs to be between 30 and 120 psi.
- If a reverse osmosis water filtration system is connected to your cold water supply, the water pressure to the reverse osmosis system needs to be a minimum of 40 to 60 psi. The reverse osmosis system must provide 1 gal. of water per hour to the icemaker for proper icemaker operation.
- **Do not use copper tubing when the icemaker is connected to a reverse osmosis water system.**

CONNECT DRAIN

This icemaker is equipped with a gravity drain to prevent water from flowing back into the storage bin and overflowing onto the floor. The ideal installation has a standpipe with a 2" to 1-1/2" PVC drain reducer installed directly below the drain tube:

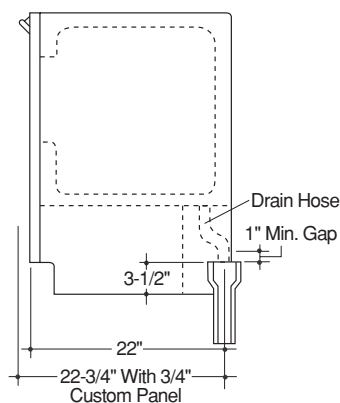

–A 1" min. physical gap between the bottom of the icemaker drain hose and the top of the house drain is required. See illustration.

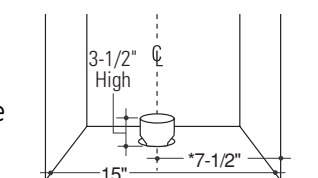

–7-1/2" to centerline of the opening.

–Approximately 3-1/2" high.

–22" from the front, or 22-3/4" when installing a 3/4" door panel.

- Drain lines must be at least 5/8" inside diameter.

NOTE: A drain pump is necessary when a floor drain is not available. Order ZPK1 Drain Pump Kit or contact your local plumber for a recommended pump available in your area.

TEST DRAIN HOSE ALIGNMENT: Before sliding the icemaker into the cabinet opening, check to be sure the bottom of the drain tube is below the rear cover. To test, place a pan below the drain hose. Pour a gallon of water into the ice bin and check to be sure that water does not wet the rear cover.

Installation Instructions

CONNECT WATER SUPPLY

- The water line should be flushed to clear any foreign material before connecting to the icemaker.
- Connect the water line to the water supply tube outside of the rear access cover.

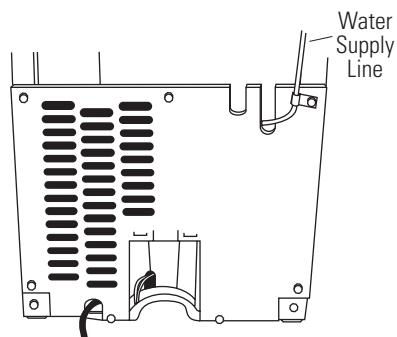

Copper Tubing:

- Use a standard plumbing female connector or union for 1/4" copper tubing that can be purchased locally.

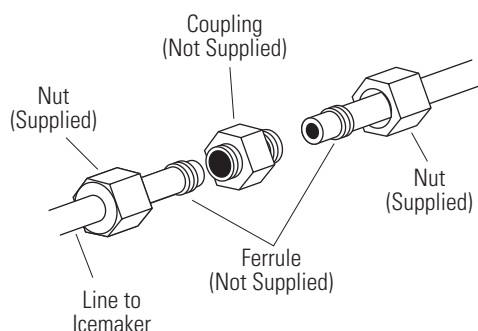

GE SmartConnect™ Tubing:

- Insert the molded end of the tubing into the icemaker connection. Tighten the compression nut until it is just hand tight.
- Tighten one additional turn with a wrench. Overtightening can cause leaks!
- Make sure there are no sharp bends or kinks that could restrict water flow.
- Slide the icemaker into its permanent location.
- To prevent rattling, be sure the copper tubing does not touch the side wall or other parts inside the cabinet.
- Open the shut-off valve. Check for leaks. Tighten any connections (including connections at the valve) if necessary.

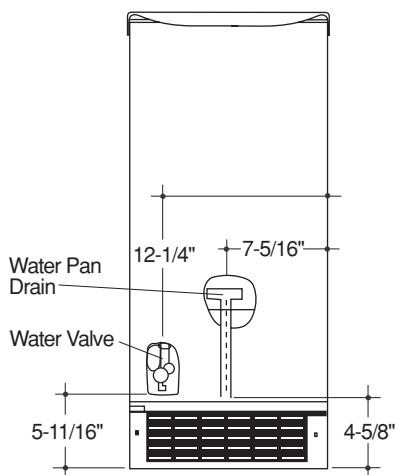

REVERSE THE DOOR SWING

IMPORTANT: Disconnect power to the icemaker.

Tools Required:

- 1/4" and 5/16" wrench
- Flat putty knife
- Phillips screwdriver

Parts Supplied:

- 4 hinge screws (on some models)

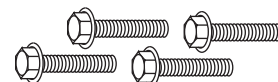

Parts Identification: (For Reference Only)



Hinge Pin



Handle Screw



5/16" Hex Head Hinge Screw



Endcap Screw

Remove door handle (black and white models):

- Remove the black or white handle.
- Remove the handle screws and lift off handle.

Remove the door (all models):

- Remove the hinge pin from the top hinge.
- Lift the door off of the bottom hinge. Place the hinge pin back into the top hinge.

For stainless steel model:

- Remove two screws each from the top and bottom of the stainless steel door skin.
- Remove the door skin and edge protectors from the door.

Reverse the door endcaps (all models):

- Remove the screws and endcaps from the door, top and bottom.
- Place the top endcap onto the bottom of the opposite side of the door with the long flat side facing the door front.
- Place the bottom endcap onto the top of the opposite side of the door, with the long flat side facing the door front.
- Set the door aside.

Installation Instructions

REVERSE THE DOOR SWING (cont.)

Reverse the hinges (all models):

- Remove the screws opposite the door hinges, top and bottom. Set aside.
- Remove the two screws holding top hinge.
- Turn the hinge upside down, with the hinge pin pointing up. Reinstall the hinge on the opposite side at the bottom of the door.
- Remove the bottom hinge. Turn the hinge upside down and install on the opposite side at the top.
- Remove the top hinge pin.

Prepare the stainless steel model door:

- Rotate the stainless steel door skin so that the handle will be on the right side. Place the stainless steel skin onto the door, keeping the edge protectors in place.
- Reinstall the two screws in the top and bottom of the door.

Reinstall the door (all models):

- Place plastic hinge sleeve on the bottom hinge and position the door onto the pin.
- Place plastic hinge sleeve in the top hinge hole on the door. Align the door on the bottom hinge and replace top hinge pin.
- Reinstall handle with original screws.

Top Hinge

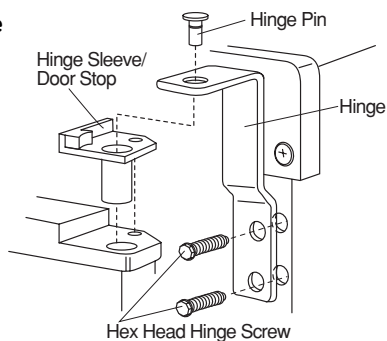

Bottom Hinge

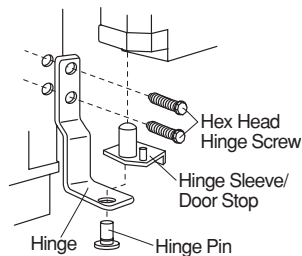

REVERSE THE DOOR SWING (cont.)

Reinstall the door (all models) (cont.):

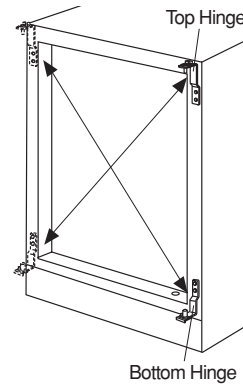

To reverse the door catch:

- Remove the plastic screws from the opposite side of the door.
- Remove the metal screws from the magnetic door catch and reinstall on the opposite side of the door.
- Install the plastic screw into place on the opposite side of the door.

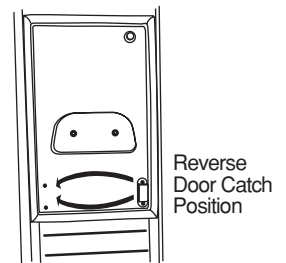

INSTALL NAMEPLATE ON STAINLESS STEEL MODELS

- Remove paper backing from the nameplate.
- Place nameplate onto the door.

Installation Instructions for ZIP75WW, ZIP75BB Kit

• BEFORE YOU BEGIN:

Read these instructions completely and carefully.

• IMPORTANT:

Save these instructions for local inspector's use.

• IMPORTANT:

Observe all governing codes and ordinances.

• **Note to Installer** – Be sure to leave these instructions with the Consumer.

• **Note to Consumer** – Keep these instructions with your Owner's Manual for future reference.



WARNING:

Disconnect electrical power supply to icemaker before installing front panel. Do not operate icemaker while installing panel. Failure to do so can result in death, fire, or electrical shock.



AVERTISSEMENT :

Il faut débrancher l'alimentation de la machine à glaçons avant d'installer le panneau avant. La machine à glaçons ne doit pas être en marche pendant l'installation du panneau avant. Le non-respect de ces instructions peut causer la mort, un incendie ou un choc électrique.

Kit Contents:

- 2 side trim pieces
- 8 side trim screws
- Door handle

Tools and Materials Required:

- 8 flat head wood screws, 1/2" long
- Drill and 1/8" bit
- Safety glasses
- Tape
- Custom panel

NOTE: If installing a 3/4" trimless custom panel, a 1-1/2" wide filler strip may be required. The filler strip will act as a spacer between the icemaker case and the adjacent cabinet, and will prevent interference with the icemaker door swing when it is installed between frameless or framed cabinetry. The width of the cutout opening must include the width of the filler strip. **The product cannot be installed flush to adjacent 24" deep cabinets with a 3/4" thick custom panel.**

This kit contains a new handle and two side mounting brackets to support a trimless custom door panel up to 3/4" thick. A custom handle may replace the supplied handle.

IMPORTANT:

- Cut edges of the custom door panel will be seen and must be finished for best appearance. The back side of the panel should be finished a minimum of 1/2" on all sides.
- The custom panel, both raised and flat design, should be constructed in the same manner as typical cabinet doors.
- Order the custom panel from the cabinet manufacturer. Be sure to provide the exact dimensions so that the panel is constructed accurately.

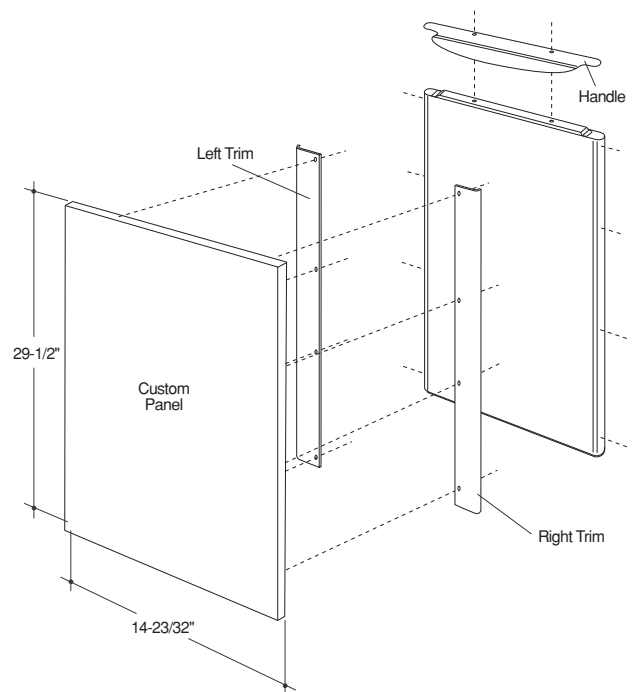

Installation Instructions for ZIP75WW, ZIP75BB Kit

STEP 1 DISCONNECT POWER TO THE ICE MACHINE

STEP 2 REMOVE HANDLE AND NAMEPLATE

- Remove the door handle by removing the two top mounting screws. Set screws aside. Discard handle.
- The Monogram nameplate is held in place with adhesive. Remove the nameplate.

STEP 3 MARK MOUNTING SCREW LOCATIONS

- Align and hold the side trim pieces against the icemaker door and mark screw locations on the sides.
- Drill 1/8" pilot holes into the door sides of the icemaker.

STEP 4 SECURE CUSTOM HANDLE TO CUSTOM PANEL. (SKIP THIS STEP IF YOU ARE USING THE SUPPLIED HANDLE)

A custom handle can be installed onto the 3/4" thick panel, replacing the supplied handle.

- The custom handle can be installed at the top or side of the panel.
- Drill pilot holes through the front of the custom panel to match the chosen handle.
- Secure the handle to the panel with flat head wood screws.
- Replace original handle screws in the top of the door frame.

STEP 5 SECURE SIDE TRIM PIECES TO CUSTOM PANEL

- Lay the custom panel appearance-side-down on a clean surface.
- Align top and bottom side trim to the custom panel sides.
- Tape the side trim pieces to the back of the custom panel.
- Place the panel with trim against the door to be sure that trim and panel fits the door side to side and top to bottom. Adjust as needed.
- Mark screw locations and remove trim. Drill pilot holes.
- Install side trim to the back side of the custom panel with screws (not supplied). Use flat head wood screws approximately 1/2" long.

STEP 6 INSTALL ASSEMBLED PANEL ONTO THE ICE MACHINE

- Install panel to icemaker with supplied screws, four on each side.

STEP 7 INSTALL SUPPLIED DOOR HANDLE (IF USED)

- Install the new supplied handle with original screws.

ZTBSS1 Monogram Tubular Handle Kit

• BEFORE YOU BEGIN:

Read these instructions completely and carefully.

• IMPORTANT:

Save these instructions for local inspector's use.

• IMPORTANT:

Observe all governing codes and ordinances.

- **Note to Installer** – Be sure to leave these instructions with the Consumer.
- **Note to Consumer** – Keep these instructions with your Owner's Manual for future reference. This kit provides a stainless steel tubular handle to coordinate with other Monogram appliances.
- The tubular handle must be installed onto the 3/4" thick portion of the custom wood panel before the panel is secured to the door.

TOOLS AND MATERIALS REQUIRED:

- Gloves to protect against sharp edges
- #2 Phillips screwdriver
- Drill and 1/4" bit and 1/2" spade bit
- Safety glasses
- Center punch
- Pencil

THIS KIT INCLUDES

- Tubular handle
- 2 Mounting screws
- 2 Handle standoffs
- 2 Set screws for standoffs
- 2 Nuts
- 2 Washers
- Allen Wrench

INSTALL THE TUBULAR HANDLE

- Use the handle as a template to locate and mark the exact position of the screw holes. Be careful to avoid interference with custom panel mounting screws.
- Draw a pencil line, top to bottom and 7/8" from the outside edge.
- Hold the tubular handle against the appearance side, centered on the marked line.
- Mark the screw hole locations at the center of the handle attachment posts.
- Center punch the marked hole locations. Drill 1/4" pilot holes from the appearance side through the entire panel thickness.
- Use a 1/2" spade bit to drill 1/4" to 5/16" deep into the back side of the panel. Insert washer (spacer) into the hole.
- Install screw through the handle standoff and into the pilot hole.
- Fasten nut onto the screw until the standoff is tight against the panel. The screw hole on the standoff should be pointing down toward the floor.
- Place handle attachment posts inside the standoffs.
- Use the Allen wrench to install the set screws. Tighten handle to standoffs.

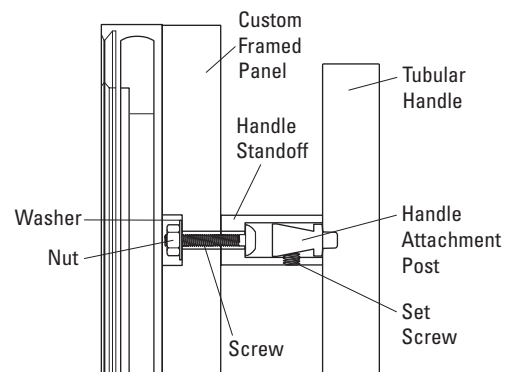
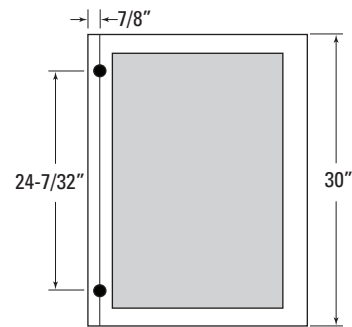

NOTE: While performing installations described in this book, safety glasses or goggles should be worn.

For Monogram® local service in your area, call 1.800.444.1845.

NOTE: Product improvement is a continuing endeavor at General Electric. Therefore, materials, appearance and specifications are subject to change without notice.

| |
|-----------------------|
| Pub. No. 31-46199-1 |
| Part No. 224D1889P001 |

W10136140A 07-07 JR
Printed in the United States



GE Consumer & Industrial
Appliances
General Electric Company
Louisville, KY 40225
ge.com