

**USE AND CARE MANUAL AND INSTALLATION INSTRUCTIONS**

# **GAS SEALED BURNER**

<b>Important Safety Instructions</b>	Inside front cover
<b>General Safety Precautions</b>	1-2
<b>Use and Care</b>	
Surface Cooking	3
Using your Oven	4-5
Using your Broiler	6
Operating your Range During an Electrical Power Failure	7
Clock and Timer (Some Models)	8
Care and Cleaning	9-12
Before you start Installing	13
<b>Installation</b>	
Backguard Installation	14-15
Clearances and Location	16
Vent Hoods	16
Anti-Tip Bracket Installation	17
Connecting the Range to Gas	18
Testing for Gas Leaks	19
Connecting the Range to Electricity (Some Models)	19
Powering Cordless Ranges (Some Models)	20
Low Battery Audible Signal	20
Replacing Weak Batteries	20
Converting Range from Natural Gas to LP (Propane) Gas	21-23
Check Surface Burner Ignition	24
Top Burner Low Flame Adjustment	24
Check Oven Burner Ignition	24
Adjust Air Shutter, If Necessary	25
Wire Diagrams	26
Before you Call for Service	27-29

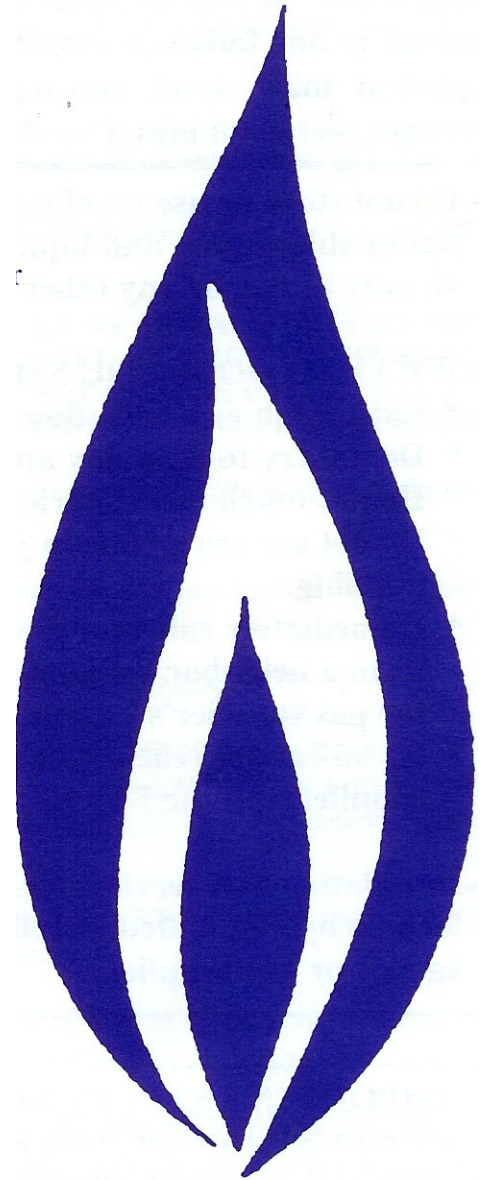

**NOTE TO CONSUMER:**

Please retain this manual for future reference.

**NOTE TO INSTALLER:**

Please leave this manual and other literature with the consumer for future use.



# IMPORTANT SAFETY INSTRUCTIONS

**WARNING:** If the information in this manual is not followed exactly, a fire or explosion may result, causing property damage, personal injury or death.

—Do not store or use gasoline or other flammable vapors and liquids in the vicinity of this or any other appliance.

—WHAT TO DO IF YOU SMELL GAS

- Extinguish any open flame.
- Do not try to light any appliance.
- Do not touch any electrical switch.
- Do not use any phone in your building.
- Immediately call your gas supplier from a neighbor's phone. Follow the gas supplier's instructions.
- If you cannot reach your gas supplier, call the fire department.

—Installation and service must be performed by a qualified installer, service agency or gas supplier.

—Have the gas system checked and leakage source corrected by a qualified installer, service agency, manufacturer or dealer or the gas supplier.

## IMPORTANT SAFETY NOTICE

The California Safe Drinking Water and Toxic Enforcement Act requires the Governor of California to publish a list of substances known to the state to cause cancer, birth defects or other reproductive harm, and requires businesses to warn customers of potential exposure to such substances.

Gas appliances can cause minor exposure to four of these substances, namely benzene, carbon monoxide, formaldehyde, and soot, caused primarily by the incomplete combustion of natural gas or LP fuels. Properly adjusted burners, indicated by a bluish rather than a yellow flame, will minimize incomplete combustion. Exposure to these substances can also be minimized by venting with an open window or using a ventilation fan or hood.



## WARNING

**NEVER** cover any slots, holes or passages in the oven bottom or cover an entire rack with materials such as aluminum foil. Doing so blocks air flow through the oven and may cause carbon monoxide poisoning. Aluminum foil linings may also trap heat, causing a fire hazard.

To reduce the risk of the appliance tipping, it must be secured by a properly installed anti-tip device. To check if this device is installed properly, remove the broiler drawer to inspect the anti-tip bracket or grasp the top rear edge of the range and carefully attempt to tilt it forward to make sure the range is properly anchored.



## WARNING



ALL RANGES CAN TIP

INJURY TO PERSONS COULD RESULT

INSTALL ANTI-TIP DEVICE PACKED WITH RANGE

SEE INSTALLATION INSTRUCTIONS



## WARNING

Improper installation, adjustment, alteration, service or maintenance can cause injury or property damage. Refer to this manual. For assistance or additional information consult a qualified installer, service agency, manufacturer (dealer) or the gas supplier.



## WARNING

To avoid the possibility of electrical shock, disconnect the power supply before servicing this unit.



## WARNING

**NEVER** use this appliance as a space heater to heat or warm the room. Doing so may result in carbon monoxide and overheating of the oven.

---

# GENERAL SAFETY PRECAUTIONS

---

**▲ WARNING: READ ALL INSTRUCTIONS BEFORE USING THIS APPLIANCE**

- 1. CAREFUL THOUGHT SHOULD BE GIVEN TO THE LOCATION OF THE RANGE.** Avoid placement in these areas: in a main "traffic path"; in an isolated area with no counter space nearby; where open range doors could create a hazard; in a drafty location which could cause the pilot to blow out.
- 2. KEEP CHILDREN AND PETS AWAY FROM THE RANGE.** Children should not play with the range controls. Range surfaces are hot. The range should not be used as a step stool to the cabinet above.
- 3. FOR SAFETY REASONS, DO NOT USE THE RANGE AS A KITCHEN HEATER.** Ovens and top burners are not designed for heating use.
- 4. BE SURE THE RANGE IS PROPERLY INSTALLED AND GROUNDED BY A QUALIFIED TECHNICIAN. BE SURE YOUR RANGE IS CORRECTLY ADJUSTED BY A QUALIFIED SERVICE TECHNICIAN OR INSTALLER FOR THE TYPE OF GAS (NATURAL OR LP) ON WHICH IT IS TO BE USED. YOUR RANGE CAN BE CONVERTED FOR USE ON EITHER TYPE OF GAS. SEE INSTALLATION INSTRUCTIONS.**
- 5. NEVER INSTALL RANGE OVER KITCHEN CARPETING.** Some carpet materials are highly flammable and some absorb grease which could be a fire hazard.
- 6. REMEMBER, FABRIC IS FLAMMABLE.** Long flowing sleeves have no place in a kitchen. Don't lean on a range. If the range is near a window, use an appropriate window treatment.
- 7. IF THE PILOT GOES OUT, YOU SHOULD DETECT A FAINT GAS ODOR AS YOUR SIGNAL TO RELIGHT THE PILOT.** As a safety measure, open a window or door to ventilate the room before relighting the pilot. If the range connections are not perfectly tight, you can have a small leak and therefore a faint gas odor. NEVER use a match or other flame to locate such a leak. Use a liquid detergent or thick soap and water solution in the areas where you think the leak might be. If a bubble develops, it indicates a possible leak. Gas supply should be turned off immediately and you should call your gas company and/or service company.
- 8. NEVER LEAVE A BURNER ON AND UNLIT FOR MORE THAN 5 SECONDS.**
- 9. ▲ WARNING: SERIOUS HAZARDS ARE ASSOCIATED WITH REACHING INTO STORAGE CABINETS ABOVE THE RANGE WHEN THE TOP BURNERS AND/OR OVEN ARE IN OPERATION.** Do not store items that are attractive to children above the range. Do not let clothing come into contact with top burners when range is in operation.
- 10. POSSIBLE HAZARDS OR INJURIES MAY RESULT FROM THE MISUSE OF APPLIANCE DOORS OR DRAWERS** such as stepping, leaning or sitting on the doors or drawers.
- 11. DO NOT USE THE TOP OF THE RANGE OR THE OVEN AS A STORAGE AREA.** Items stored on the range top can become too hot and melt. Do not store flammable materials in the oven.
- 12. USE A GOOD POTHOLDER WHEN PULLING OUT OVEN RACKS TO ADD OR REMOVE FOOD.** Dish towels or other substitutes can cause bad burns. Use only dry potholders. Damp or moist potholders on hot surfaces may result in burns from steam. Do not let a potholder touch a flame.
- 13. KEEP ALL PLASTICS AWAY FROM THE RANGE,** as plastics are vulnerable to heat.
- 14. AVOID UNSTABLE, EASILY TIPPED PANS.** Pan handles should be turned to the back or side of the range – not out into the room or over adjacent burners. Only use utensils that are suitable for range and oven use.



# GENERAL SAFETY PRECAUTIONS

15. **DO NOT HEAT UNOPENED CONTAINERS OR FOOD ON SURFACE BURNERS OR IN THE OVEN.** Buildup of pressure may cause the container to burst and result in serious personal harm and/or damage to the range.
16. **ALUMINUM FOIL WHEN USED IMPROPERLY IS A CAUSE OF MANY RANGE PROBLEMS.** See the oven and broiler sections of this book for instructions for proper use.
17. **GREASE IS FLAMMABLE AND SHOULD BE HANDLED CAREFULLY.** Avoid letting grease deposits collect around the range or in vent fans. Let quantities of hot fat, a pan of deep fat for example, cool before attempting to move it. If a grease fire should occur in a pan, put out the flame by placing a lid on the pan. **DO NOT** throw water on a grease fire. Do not turn on the vent hood. Use a dry chemical or foam type fire extinguisher. If a fire should occur in the oven or broiler, turn off the oven, close the oven door and broiler door to allow the food or grease to burn itself out in the oven. If smoke or fire persist, call you local fire department.
18. **AVOID THE USE OF AEROSOL SPRAYS NEAR A RANGE AS MOST ARE FLAMMABLE.**
19. **NEVER LEAVE SURFACE BURNERS UNATTENDED AT HIGH OR MEDIUM FLAME SETTINGS.** Adjust top burner flame size so it does not extend beyond the edge of the cookware. Excessive flame is hazardous.
20. **DO NOT TOUCH THE INTERIOR SURFACES OF THE OVEN DURING OR IMMEDIATELY AFTER USE.** Do not let clothing or other flammable materials contact burners. Although these surfaces may be dark in color they can still be hot enough to burn. Other areas of the range can become hot enough to cause burns, such as vent openings, main top, window, oven door, broiler door and oven racks.
22. **DO NOT OBSTRUCT THE FLOW OR COMBUSTION OR VENTILATION AIR.**
23. **BE SURE ALL PACKING MATERIALS ARE REMOVED FROM THE RANGE** before operating it to prevent fire or smoke damage should the packing material ignite.
24. **LEAK TESTING OF THE APPLIANCE SHALL BE CONDUCTED ACCORDING TO THE MANUFACTURER'S INSTRUCTIONS.**
25. **THIS RANGE IS NOT TO BE INSTALLED WITH OVERHEAD RANGE HOODS WHICH OPERATE BY BLOWING A DOWNWARD AIRFLOW OR AIR CURTAIN ONTO THE RANGE.** This type of ventilation system may cause ignition and combustion problems with your gas cooking appliance resulting in personal injury or unintended operations.



## UNPACKING:

Remove all tape, wrapping paper, and packing material from the exterior of the range. Be sure to remove the protective plastic from control panel and all stainless parts of the range.

Remove all packing from the oven or broiler compartments.

# SURFACE COOKING

## BURNER LIGHTING SOURCE

The burners on your range need an electrical source to ignite the burners. The electricity required to light the burners may come from an electrical outlet or from a battery power pack. Ranges without a power cord have a battery power pack located in the lower right corner of the range.

In either case your new range is equipped with automatic ignition top burners. Each burner can be controlled to provide heat from the highest “full on” to the very low “keep warm”. The burner knob can be set to any position for the flame desired.

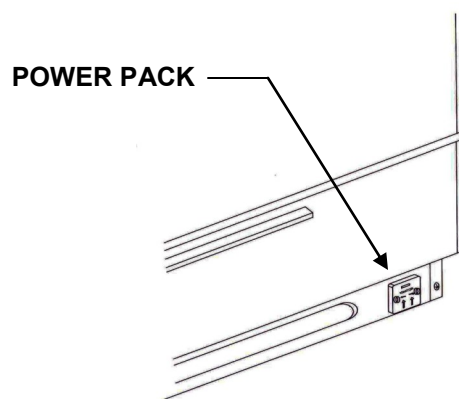

**CONTROL PANEL** located on front of range to allow easy reach of all range controls.

- A. LIGHT SWITCH (OPTIONAL)    B. RIGHT FRONT CONTROL KNOB    C. RIGHT REAR CONTROL KNOB  
D. OVEN CONTROL KNOB    E. GRIDDLE CONTROL KNOB-OPT.    F. LEFT FRONT CONTROL KNOB  
G. LEFT REAR CONTROL KNOB    H. SURFACE BURNER LOCATION INDICATOR

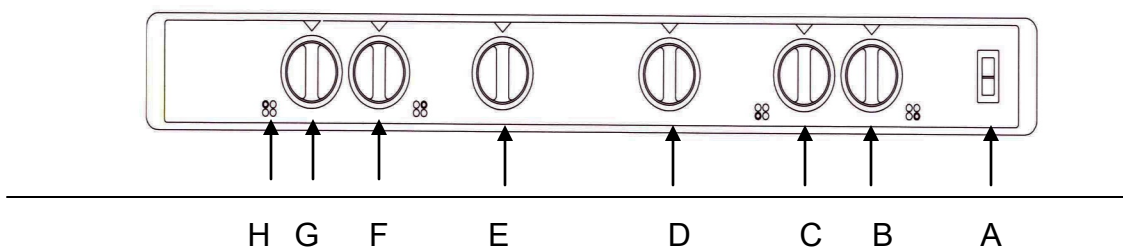

## TO LIGHT A SURFACE BURNER

Push the control knob in and turn it to the LITE or START position. You will hear a clicking noise– the sound of the electric spark. After the burner ignites, turn the knob to adjust the flame size. **NOTE: ALL IGNITORS WILL SPARK WHEN ANY CONTROL KNOB IS TURNED TO THE LITE POSITION.**

## FOR BEST RESULTS

The gas burner adjust to any flame desired and allows you to tailor the flame to fit any pan large or small.

Always position the utensil on the burner grate **BEFORE** lighting the burner. **FOR YOUR SAFETY,** the flame should not extend beyond the sides of the pan.

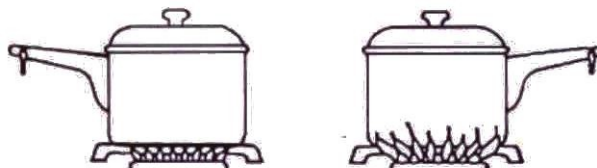

# USING YOUR OVEN

To use your oven, push and rotate the oven control counterclockwise to the “PILOT” or “LITE” position. Once in the “PILOT” or “LITE” position, push in on the knob as far as possible and hold for 10 sec. After holding the control knob in for 10 sec. release the oven knob. The pilot flame will remain lit. Open the oven door. When you push in and rotate the oven control knob to the desired position (temp.), watch for burner ignition through the hole located at the front center of the oven bottom. If the oven control knob does not have a “PILOT” or “LITE” position, the oven employs a hot surface igniter to light the oven burner. Select a cooking temperature. After approximately 30-60 seconds the oven burner lights the temperature will climb to the set temperature. Once the temperature is reached the oven burner will cycle off and on maintaining the oven temperature.

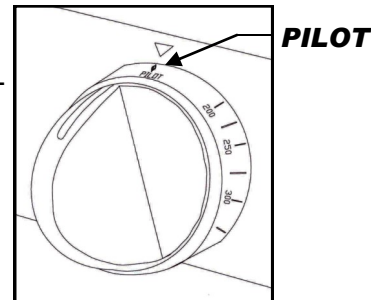

TEMPERATURE CONTROL

## INITIAL OVEN OPERATION

Slight odor or smoke from the insulation around the oven lining is normal for the first few times the oven is used. This is temporary.

## OVEN RACKS

The racks are designed with stop locks. When placed correctly on the rack supports they will stop before coming completely out of the oven and will not tilt when you are removing food from them or placing food on them.

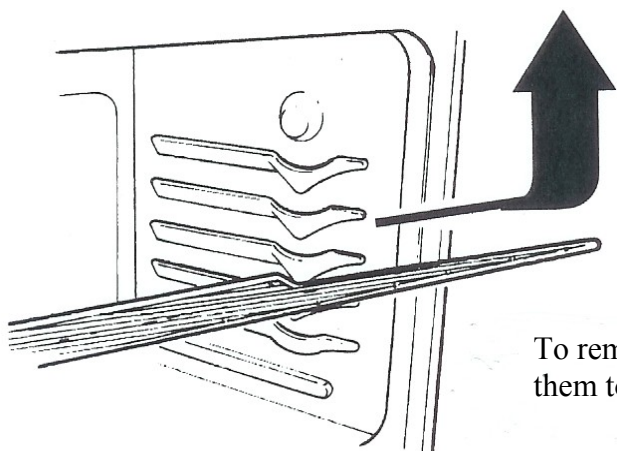
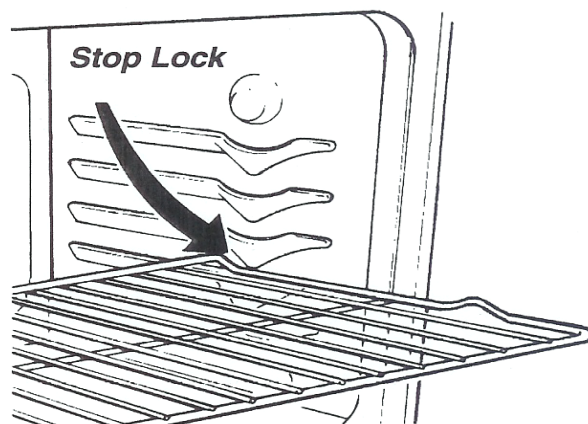

To remove the racks from the oven, pull them toward you, tilt front end upward

***DO NOT USE OVEN COMPARTMENT FOR STORAGE AREA. ITEMS STORED IN THE OVEN CAN IGNITE.***

***PLACE OVEN RACKS IN THE DESIRED POSITION WHILE OVEN AND OVEN RACKS ARE COOL.***

# USING YOUR OVEN

## OVEN VENT

The oven is vented at the back of the cooktop. When the oven is on, warm air is released through the vents. This venting is necessary for proper air circulation in the oven for good baking results.

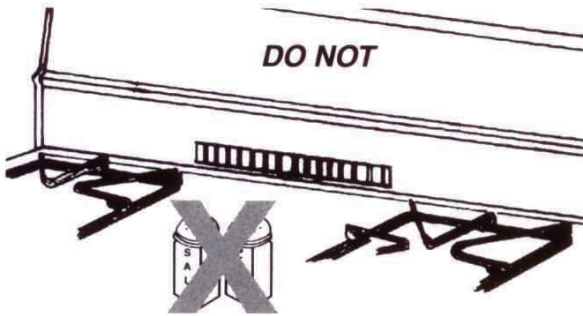

- \* **DO NOT LEAVE PLASTIC ITEMS ON THE COOKTOP. THEY MAY MELT IF LEFT TOO CLOSE TO THE VENTS OR BURNERS.**
- \* **METAL ITEMS WILL BECOME VERY HOT IF THEY ARE LEFT ON THE COOKTOP AND COULD CAUSE BURNS.**
- \* **VENT OPENINGS AND NEARBY SURFACES MAY BECOME HOT. DO NOT TOUCH THEM.**
- \* **HANDLES OF POTS AND PANS ON THE COOKTOP MAY BECOME HOT IF LEFT TOO CLOSE TO THE VENTS.**

**▲ WARNING: THE COOKTOP WILL BECOME HOT FROM THE OVEN VENTING WHEN THE OVEN IS IN OPERATION.**

## BAKING

Your new oven may heat differently than your old oven. The times and temperatures to which you have been accustomed may vary slightly because of these differences.

Preheat the oven for at least ten (10) minutes before baking.

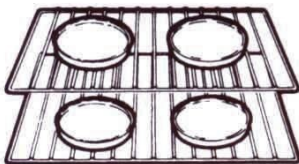

- \* **KEEP OVEN FREE FROM GREASE BUILDUP.**
- \* **PLACE OVEN RACKS IN DESIRED POSITION WHEN THE OVEN AND OVEN RACKS ARE COOL.**
- \* **WHEN USING COOKING OR ROASTING BAGS IN OVEN, FOLLOW THE MANUFACTURER'S DIRECTIONS.**

## ROASTING

Roasting is oven cooking of tender cuts of meat and poultry. Low temperature roasting cooks meat to an appetizing brown without undue loss of juices and minimum shrinkage. It also reduces spattering and keeps oven cleanup at a minimum.

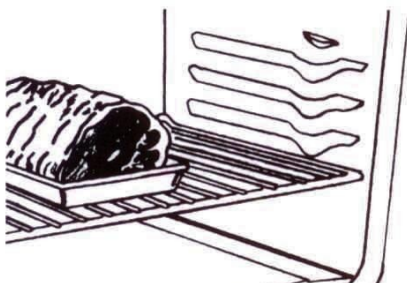

- \* **STAND AWAY FROM THE RANGE WHEN OPENING THE DOOR OF A HOT OVEN. THE HOT AIR AND STEAM WHICH ESCAPE CAN CAUSE BURNS.**
- \* **PULLING OUT RACK TO THE RACKSTOP IS A CONVENIENCE IN LIFTING HEAVY FOODS.**
- \* **DO NOT PLACE HEAVY FOODS ON OVEN DOOR.**



# USING YOUR BROILER

---

## OVEN MOISTURE

As your oven heats up, the temperature change of the air in the oven may cause water droplets to form on the door glass. These droplets are harmless and will evaporate as the oven continues to heat up.

- \* **NEVER USE FOIL TO COMPLETELY COVER OVEN RACKS OR BLOCK ANY OF THE OPENINGS IN THE OVEN BOTTOM.**

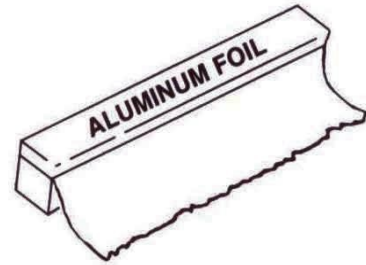

## BROILING

Broiling is a fast method for cooking tender cuts of meats, poultry, ham and fish. The broiler compartment is located beneath the oven. Pull the entire broiler compartment forward to the stop position. The broiler compartment door folds down to allow for easy removal of the broiler pan for turning foods. Gas broiling is cool and clean since broiling is done with the broiler door closed and any smoke is consumed by the flame. To operate broiler, Push-turn the oven control counterclockwise to the BROIL position.

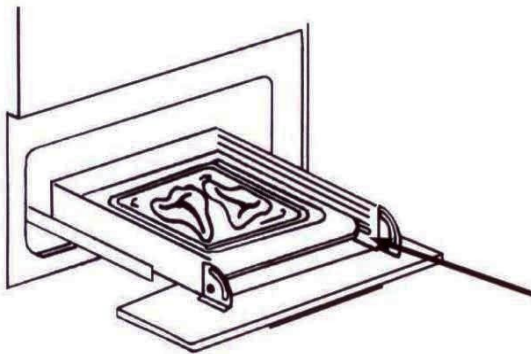

- \* **WHEN BROILING, IF MEAT IS TOO CLOSE TO THE FLAME, THE FAT MAY IGNITE.**

Cooking times for broiled food vary considerably. There are differences in thickness of meat, in fat content, and in personal preferences. Generally, the distance between the top of the meat and the broiler flame regulates the degree of doneness and the broiling time.

Different broiler tray locations are provided to accomplish your cooking needs.

- \* **BROILER PAN AND TRAY MUST BE IN PLACE FOR ANY COOKING OPERATION.**

- \* **NEVER COVER THE BROILER RACK OPENINGS WITH ALUMINUM FOIL. IF THE RACK IS COVERED BY ALUMINUM FOIL, THE FAT CANNOT DRIP AWAY FROM THE MEAT AND MAY EASILY IGNITE.**

- \* **IF YOU SHOULD HAVE A GREASE FIRE IN THE BROILER, TURN OFF THE BROILER AND KEEP THE DRAWER CLOSED TO CONTAIN THE FIRE UNTIL IT BURNS OUT.**

- \* **ALWAYS REMOVE THE BROILER PAN FROM THE BROILER COMPARTMENT AS SOON AS BROILER PAN COOLS. GREASE LEFT IN THE PAN CAN CATCH FIRE IF THE OVEN IS USED WITHOUT REMOVING THE GREASE FROM THE BROILER PAN. REPLACE BROILER PAN AND TRAY AFTER CLEANING.**

- \* **DO NOT USE BROILER COMPARTMENT AS A STORAGE AREA. ITEMS STORED IN THE BROILER COMPARTMENT CAN IGNITE OR CAUSE DAMAGE TO THE PILOT OR SAFETY VALVE SENSING BULB.**

- \* **DO NOT USE PANS OR DISHES IN THE BROILER COMPARTMENT.**



# OPERATING YOUR RANGE DURING AN ELECTRICAL POWER FAILURE

**⚠ WARNING: USE EXTREME CAUTION WHEN LIGHTING BURNERS THIS WAY**

## LIGHTING TOP BURNERS

1. Hold a lighted match to the desired burner head.
2. Push and turn the control knob to the “LITE” or “START” position.
3. After burner lights, adjust flame to desired size as required.

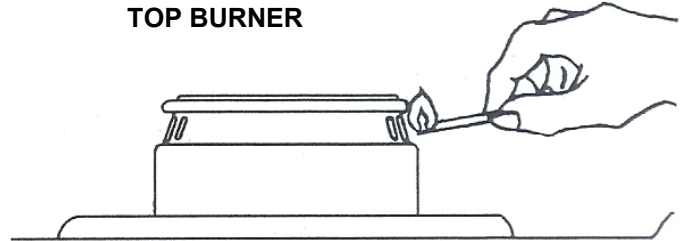

## LIGHTING OVEN BURNER

Before attempting to light the oven burner, it is important to determine whether the oven in your range will operate during an electrical outage. To make this determination it is necessary to identify the type of oven system that your range employs. The easiest way to check this is to look at the first letter of your range model number. **If your range model number starts with an “S” it can not be operated during a power outage.** Refer to the back cover of your manual to find the location of the model number rating plate. Follow the oven lighting instruction below if your range model number starts with a “T”.

## LIGHTING OVEN BURNER

1. Remove the oven bottom (See page 11). After removing the oven bottom, remove the oven burner baffle plate from the top of the oven burner.
2. Rotate the knob to the “PILOT” or “LITE” position. Push in and hold the oven control knob.
3. Place a lit match or lighter at the pilot to light it. Continue to hold in on the control knob for 10 seconds. See drawing.
4. After the 10 sec. hold period release the knob. The pilot flame should remain lit. Once the pilot is lit, replace the burner baffle and oven bottom. If the oven pilot does not remain lit repeat steps 2-4.
5. Push in and rotate the oven control knob to the desired baking temperature. Upon selecting the cooking temperature, open the oven door to observe that the burner flame has lit by looking through the observation hole in the front center of the oven bottom.
6. The oven will continue to cook normally until the Oven Control Knob is rotated to the “OFF” position.

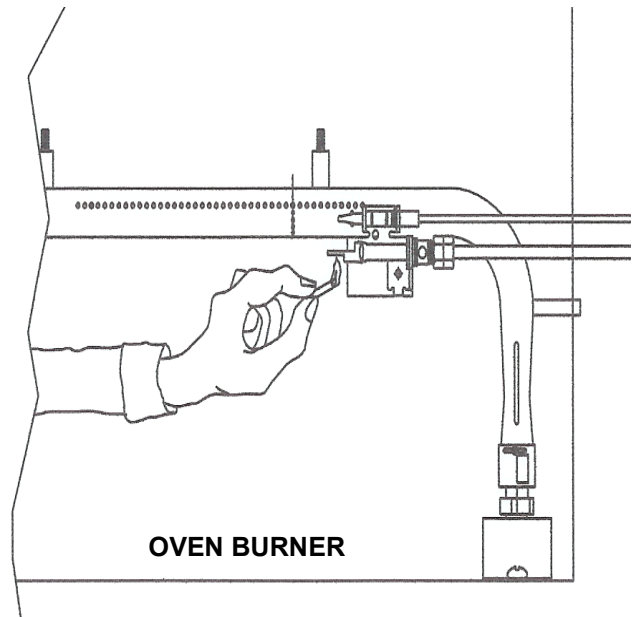

**NOTICE:** *The surface and oven burners in use when an electrical power failure occurs will continue to operate normally until shut off.*

# CLOCK AND TIMER (Optional on Some Models)

## ELECTRONIC CLOCK AND TIMER

**TO SET TIME OF DAY:** Depress “CLOCK” button (a tone will sound). Depress “UP” button to set the time up, or depress “DOWN” button to set the time down. Tapping the “UP” OR “DOWN” button will increase or decrease the time by 1 minute. Holding in the “UP” or “DOWN” button will increase or decrease the time in 10 minute intervals. After the correct time has been set, depress the “CLOCK” button (a tone will sound) or wait 7 seconds and the correct time will be set.

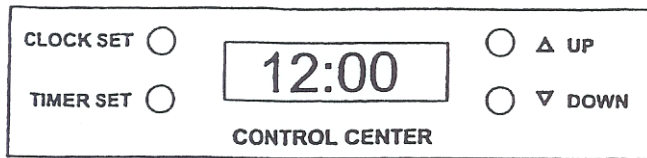

**TO SET TIMER:** Depress “TIMER” button (a tone will sound). Depress “UP” button to set the time up, or depress “DOWN” button will increase or decrease the time by 1 minute. Holding in the “UP” or “DOWN” button will increase or decrease the time in 10 minute intervals. 7 seconds after the last programming input, the timer becomes active. When 1 minute is remaining on the timer, a 1 second tone will sound. When the timer reaches zero (00:0), there will be three tones 1 second apart, then a tone every 10 seconds for 10 minutes.

**NOTES:** The colon flashes when the timer is active whether the timer or the time of day is displayed. To display the time of day when in the timer mode, depress the “CLOCK” button. To cancel the timer, depress the “TIMER” button once when the timer is displayed or twice when the time of day is displayed.

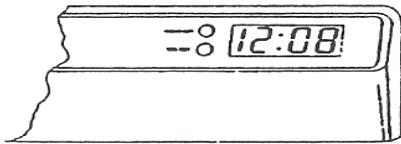

## ELECTRONIC CLOCK-NO TIMER

**TO SET TIME OF DAY:** Depress hour set button until the correct hour of the day is displayed on the clock. Depress minute set button until the correct minute of the day is displayed.

# CARE AND CLEANING

## CLEANING PORCELAIN OVEN INTERIOR

Porcelain has a smooth finish, and is a type of glass fused to metal. With proper care, the porcelain enamel walls in these ovens will retain their good looking finish for many years.

**▲ WARNING: KEEP APPLIANCE AREA CLEAR AND FREE FROM COMBUSTIBLE MATERIALS, GASOLINE AND OTHER FLAMMABLE VAPORS AND LIQUIDS.**

Food soil that is allowed to harden and bake on can be difficult to remove. Clean the oven before it is entirely cool (not while it is hot) with detergent and water - using a soap-filled steel wool pad on burned spots. Rinse and wipe dry.

## COMMERCIAL OVEN CLEANER

Commercial oven cleaners may be used on conventional porcelain lined ovens. Follow instructions carefully. After using cleaners, thoroughly rinse the oven with a solution of one tablespoon vinegar to one cup water. Oven cleaners can coat or damage the thermostat sensing device (long tube in the oven) so that it will not sense temperature correctly. If you are using an oven cleaner, try to avoid any contact with the rod-shaped bulb of the thermostat. Be sure that any residue that touches the bulb is carefully removed.

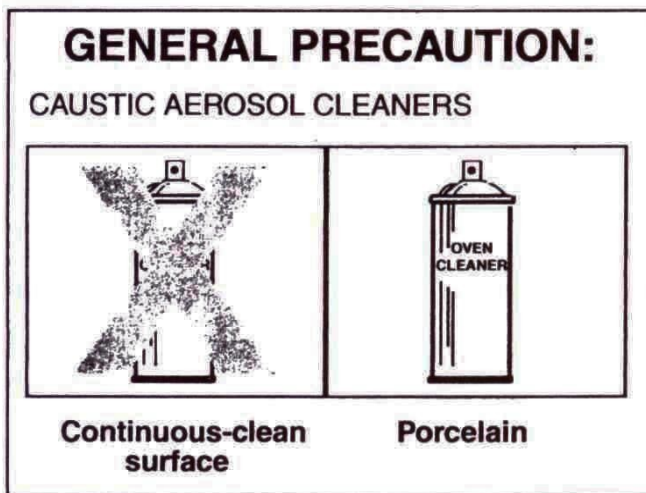

**\* DO NOT SPRAY ANY OVEN CLEANER ON THE OVEN DOOR HANDLES OR ANY EXTERIOR SURFACE OF THE OVEN, WOOD OR PAINTED SURFACES. THE CLEANER CAN DAMAGE THESE SURFACE.**

**\* DO NOT SPRAY ON THE ELECTRICAL CONTROLS AND SWITCHES BECAUSE IT COULD CAUSE A SHORT CIRCUIT AND RESULT IN SPARKING OR FIRE.**

**\* DO NOT ALLOW A FILM FROM THE CLEANER TO REMAIN ON THE**

**TEMPERATURE SENSING BULB (THE BULB IS LOCATED AT THE TOP LEFT SIDE OF THE OVEN). CAREFULLY WIPE THE BULB CLEAN AFTER EACH OVEN CLEANING, BEING CAREFUL NOT TO MOVE THE BULB AS A CHANGE IN ITS POSITION COULD AFFECT HOW THE OVEN BAKES.**

## OVEN RACKS

Oven racks are removed by pulling forward, tilting and lifting up. Racks may be washed with detergent and water. Scour heavily soiled areas with a soap-filled steel wool pad.

## OVEN WINDOW

Oven windows may be washed with a damp cloth dipped in detergent and warm water, or a solution of baking soda and water.

**Note of Caution: Spray-on/wipe-off cleaners should not be sprayed on a hot or warm oven because they will leave a hard to remove stain. When used on a cold oven, the cleaner should be completely rinsed away to avoid any possibility of staining.**



# CARE AND CLEANING

## CLEANING OVEN BOTTOM

Clean using warm, sudsy water, a mild abrasive cleaner, or a soap filled abrasive pad or commercial oven cleaner following the manufacturer's instructions.

The oven bottom on the 24", 30", and 36" models can be removed for cleaning by sliding the oven bottom towards the rear wall, lifting the front end up to clear the front frame, and gently pulling the oven bottom out and up.

## CLEANING PORCELAIN RANGE TOP AND BACKGUARD

Clean using hot, sudsy water, a soap filled abrasive pad, or a mild abrasive cleaner following the manufacturer's instructions.

## CLEANING STAINLESS STEEL OVEN DOORS

Clean using hot, sudsy water, a soap filled abrasive pad, or a mild abrasive cleaner followed by a Stainless Steel Cleaner.

## CLEANING BROILER PAN (if equipped):

After broiling, remove the broiler pan and tray after allowing them to cool. Wash in warm, soapy water.

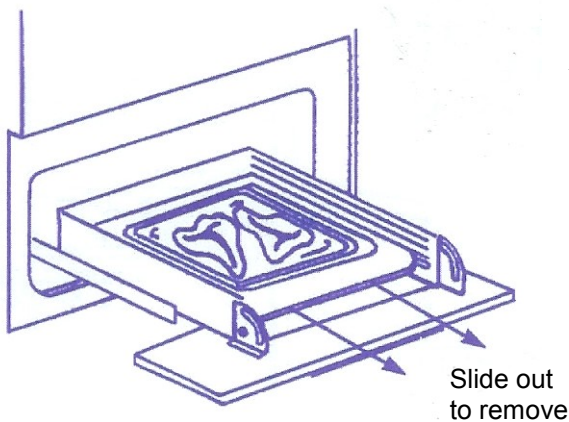

***\* BROILER PAN AND TRAY MUST BE IN PLACE FOR ANY COOKING OPERATION.***

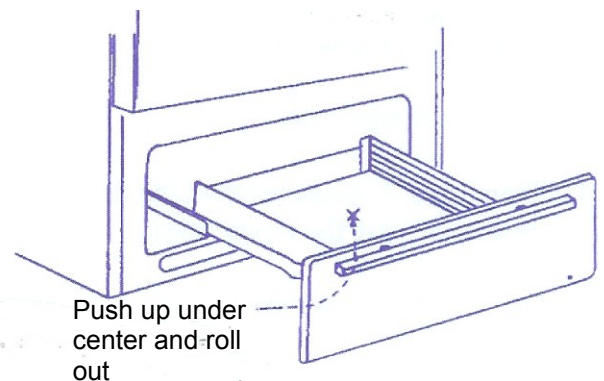

**DO NOT USE STEEL WOOL PADS, COMMERCIAL OVEN CLEANER, SILICONE OVEN SPRAYS, COARSE PADS OR COARSE BRUSHES ON THE BROILER CARRIAGE.**

# CARE AND CLEANING

## REMOVING MAIN TOP

It is not common to remove the sealed burner main top unless service is required. To remove top:

1. Pull range away from the wall and disconnect the range electrical supply and shut off range gas supply.
2. Remove top burner grates.
3. Remove the burner caps from each top burner.
4. From back of range, remove the (2) nuts (1 per side) holding the range main top to the range sides. See Fig. 1
5. Lift burner base off range main top. On some models the burner base may be held in place with screws. Remove (2) screws holding each burner base to the main top. See Fig. 2
6. Remove (2) screws holding the orifice holder to the range main top. See Fig. 3
7. Lift main top off of range by raising the top while pulling forward to unhook the top from the control panel.

\* Note: Illustrations may not be visually representative of the actual burner used on your range.

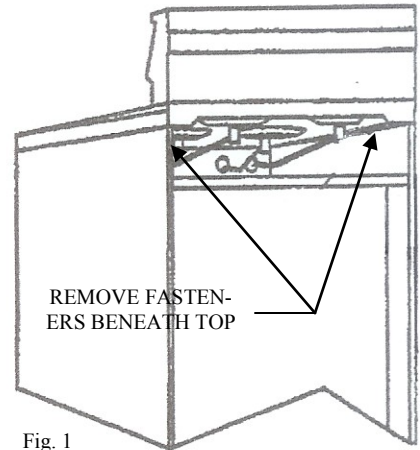
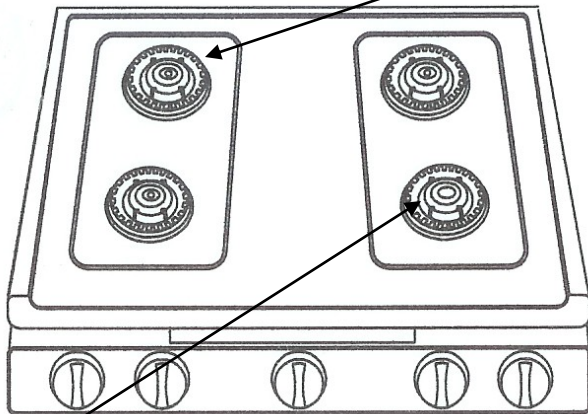

Fig. 1

Fig. 2

BURNER BASE



If burner base will not lift off. Remove (2) screw holding burner base to cooktop.

Fig. 3

ORIFICE HOLDER

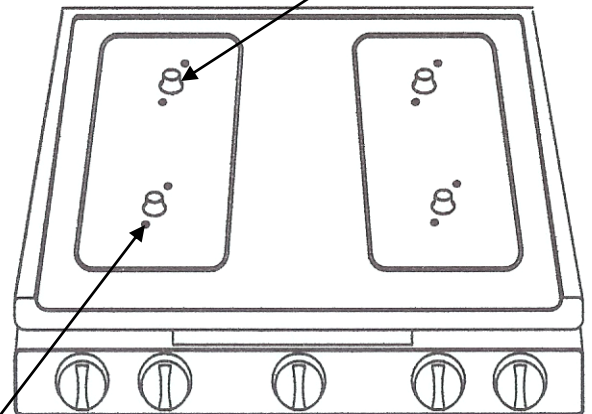

Remove (2) screws from each orifice holder.

# CARE AND CLEANING

## CLEANING TOP BURNER GRATES

Wash burner grates in warm, soapy water. Dry the grates with a cloth. When replacing the grates, be sure they are properly positioned over the burners.

**NOTE: Do not operate a burner for an extended period of time without cookware on the grate. The finish on the grate may chip without cookware to absorb the heat.**

## CLEANING TOP BURNERS

The burner ports of your range must be kept clean at all times for proper ignition and flame. You should clean the burner routinely, and especially after bad spillovers. If the food does not wash off completely, scrub with a brush or plastic pad and soap and water. Dry burner as thoroughly as possible, especially around the burner igniter.

**DO NOT USE STEEL WOOL OR ABRASIVE CLEANERS.**

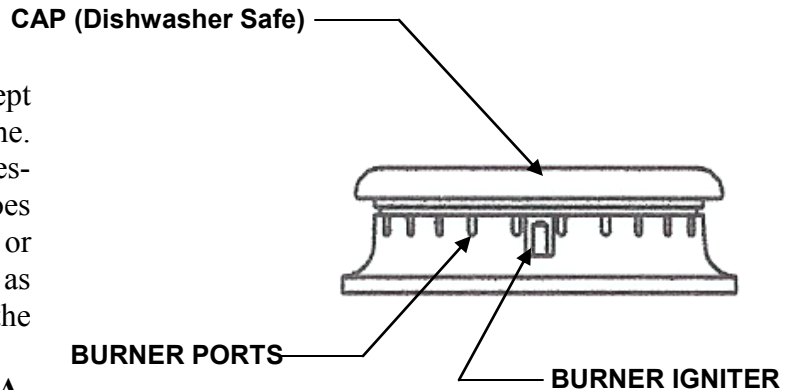



# BEFORE YOU START INSTALLING

## IMPORTANT NOTE TO INSTALLER:

*BEFORE YOU BEGIN – READ THESE INSTRUCTIONS COMPLETELY AND CAREFULLY.*

*BE SURE TO LEAVE THESE INSTRUCTIONS WITH THE CONSUMER.*

## IMPORTANT NOTE TO CONSUMER:

*KEEP THESE INSTRUCTIONS FOR FUTURE REFERENCE. OBSERVE ALL GOVERNING CODES AND ORDINANCES. SAVE THESE INSTRUCTIONS FOR LOCAL INSPECTORS.*

## **⚠ WARNING**

### **Excessive Weight Hazard**

Use two or more people and wear gloves and safety glasses to move and install the range. Failure to do so can result in back or other injury.

Keep cardboard shipping base under range to prevent damage to floor coverings.

Remove oven racks and parts package from inside oven.

Remove shipping materials, tape and protective film from range.

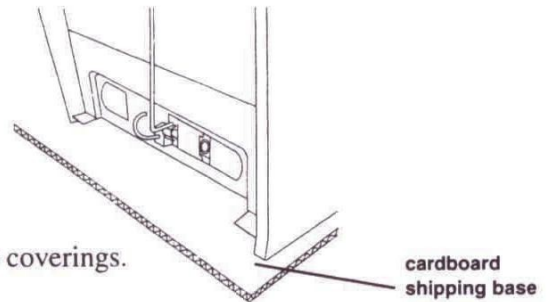

## GAS AND ELECTRIC REQUIREMENT LOCATION

MODEL	DIM. "A"
20	12-1/4"
24"	16-3/16"
30"	22-3/16"
36"	28-3/16"

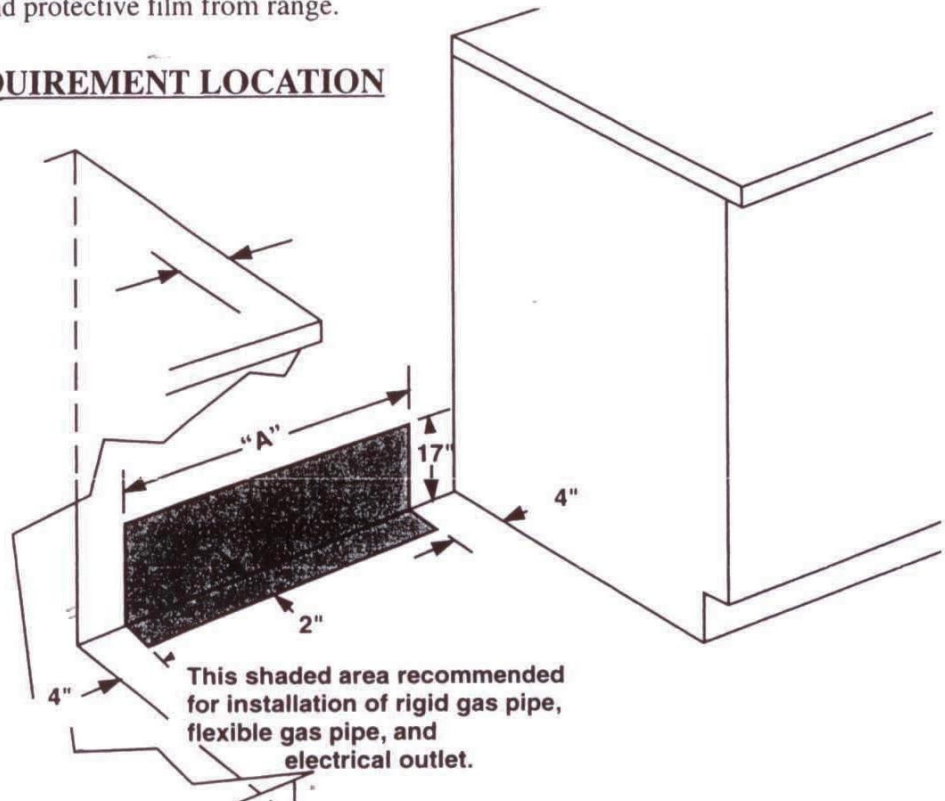

# INSTALLATION INSTRUCTIONS

## **PORCELAIN BACKGUARD INSTALLATION**

1. Remove range main top. (See Page 11)
  2. Position backguard down over flue box onto range main sides.
  3. Assemble backguard to range main sides with (2) (A) bolts and (2) (C) sheet metal screws.
  4. If backguard has a clock, connect plug (D) from backguard to plug (D) from back of range.
  5. Replace range main top.
- 

## **THERMOPLASTIC END CAP BACKGUARD INSTALLATION**

1. Remove range main top. (See Page 11)
2. Position backguard down over backguard support and flue box.
3. Screw (2) (A) black sheet metal screws through backguard end caps into backguard support ends.
4. From rear of unit, screw (2) (B) long sheet metal screws through back of backguard end caps into backguard support.
5. If backguard has a clock, connect plug (D) from backguard to plug (D) from back of range.

## **VENT RAIL BACKGUARD INSTALLATION**

---

1. Remove range main top. (See Page 11)
2. Lower vent rail over flue box and down on range main side matching up holes in vent rail with holes on the top rear flange of range main sides.
3. Fasten vent rail to top flange of main side with (2) (A) bolts and (2) (A) sheet metal screws.

# INSTALLATION INSTRUCTIONS

---

## PORCELAIN BACKGUARD

Fasteners included for assembly:

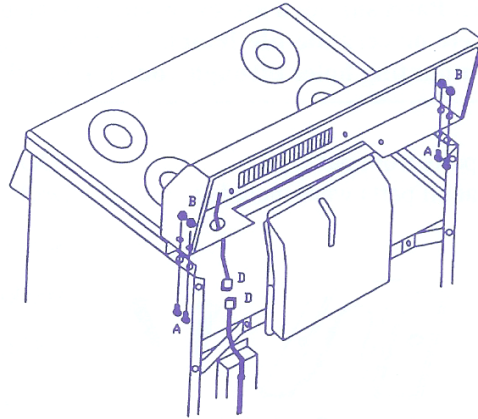

---

## THERMOPLASTIC END CAP BACKGUARD

Fasteners included for assembly:

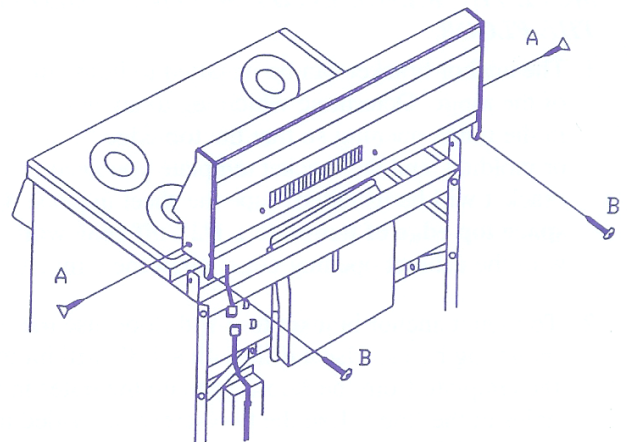

---

## VENT RAIL BACKGUARD

Fasteners included for assembly:

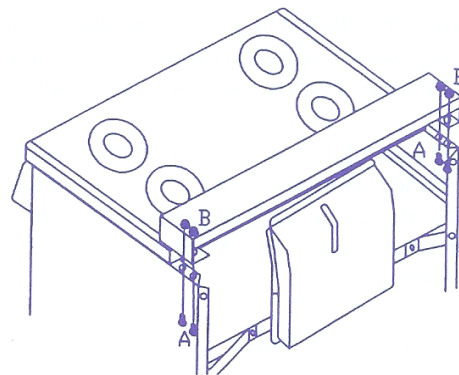
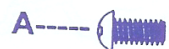



# INSTALLATION INSTRUCTIONS

## MAXIMUM AND MINIMUM CLEARANCES

The sides of the range can be flush to combustible material below the cooking top. The back of the range can be flush to combustible material. A minimum clearance of 5 inches is required between the range and combustible construction extending from the cooking surface to 18 inches above the level of the cooking surface. A minimum clearance of 30 inches is required between the cooking surface and any combustible material directly above the cooking surface.

## LOCATION

Do not locate the range where it may be subject to strong drafts. Any openings in the floor or wall behind the range should be sealed. Make sure the openings around the base of the range that supply fresh air for combustion and ventilation are not obstructed by carpeting or woodwork.

**IMPORTANT: THE RANGE SIDE PANELS SHOULD STICK OUT BEYOND THE CABINET FRONTS AT LEAST 1/4" WHERE 0" CLEARANCE (FLUSH) OF SIDE WALLS IS DESIRED.**

**CAUTION: NOT ALL CABINET AND BUILDING MATERIALS ARE DESIGNED TO WITHSTAND THE HEAT PRODUCED DURING THE NORMAL SAFE OPERATION OF A LISTED APPLIANCE. DAMAGE SUCH AS DISCOLORATION OR DELAMINATION MAY OCCUR.**

## VENT HOODS

**IMPORTANT: THIS RANGE IS NOT INTENDED FOR USE IN CONJUNCTION WITH A VENTILATION SYSTEM WITH PROVISIONS TO DIRECT AIR IN A DOWNWARD DIRECTION, TOWARD THE RANGE. THIS TYPE OF VENTILATION SYSTEM MAY CAUSE IGNITION AND COMBUSTION PROBLEMS WITH YOUR GAS COOKING APPLIANCE RESULTING IN PERSONAL INJURY OR UNINTENDED OPERATIONS.**

## ***13" MAXIMUM CABINET DEPTH INSTALLED ABOVE THE RANGE***

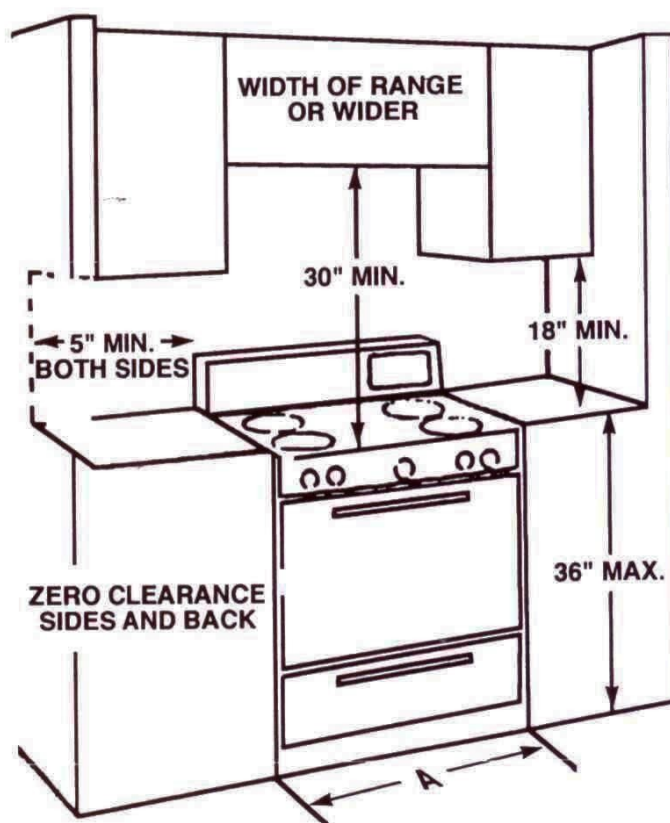

Nominal Width of Range	Recommended Minimum Installation Clearance (Dim. A)
20"	20-1/4"
24"	24-3/16"
30"	30-3/16"
36"	36-3/16"

# INSTALLATION INSTRUCTIONS

## ANTI-TIP BRACKET INSTALLATION

The anti-tip bracket is installed to prevent the range from tipping forward as the result of excessive downward pressure on the open end of the oven door. All ranges are required to have an approved anti-tip bracket installed. The anti-tip bracket is packed in the oven section of the range.

If you did not receive an anti-tip bracket with your purchase, call 1-800-858-5844.

	<b>WARNING</b>
	<p>A child or adult can tip the range and be killed. Install the anti-tip device to the floor or the wall of the structure.</p> <p>Engage the range to the anti-tip device that is fastened to the wall or the floor.</p> <p>Re-engage the anti-tip device if the range is moved.</p> <p>Failure to do so can result in death or serious burns to children or adults.</p>

**NOTICE:** Parts supplied are for wood, concrete or ceramic tile floors. The plastic anchors are for mounting to concrete or ceramic floors or walls. Contact a qualified floor covering installer for the best procedure for drilling mounting holes through your type of floor covering.

### STEP 1

It is necessary to determine the final location of the range before you can locate the anti-tip bracket. If the range is going to be located between cabinets, place the bracket so that **Edge A** sits flat against the rear wall. **Edge B** should just touch the side of the cabinet sitting to the **right side** of the range.

If there are no adjacent cabinets, align **Edge B** of the bracket with the edge of the range side. After the bracket has been placed mark the hole locations with a marker.

### STEP 2

The anti-tip bracket can be attached to the floor or the wall. For wall mount application use **Location C**. When using location C, the screws must penetrate the wall sill plate located within the wall. For floor mount application use **Location D or E**. One screw on each side of the bracket is sufficient.

### STEP 3

To mount anchor bracket to concrete or ceramic floor, use a drill with a 3/16" masonry bit to drill the two holes. Tap plastic anchor into mounting holes in floor with hammer. Line up holes in anti-tip bracket to holes in floor. Use the two screws provided to fasten anti-tip bracket to floor. When using a Hilti DX-460 tool or equivalent, locate the 3 (X's) on the anti-tip bracket and drive a 1-1/4" X 1/4" pin through the anti-tip bracket. To properly set the pin, it must penetrate 1-1/4" through the floor covering and into the floor. With the Hilti DX-460 a #3 setting is recommended.

### STEP 4

Unscrew the rear leg levelers approximately 1/2" so that the rear leg levelers will slide in under the anti-tip bracket. Slide range into the final position after completing the gas and electrical connections to the range.

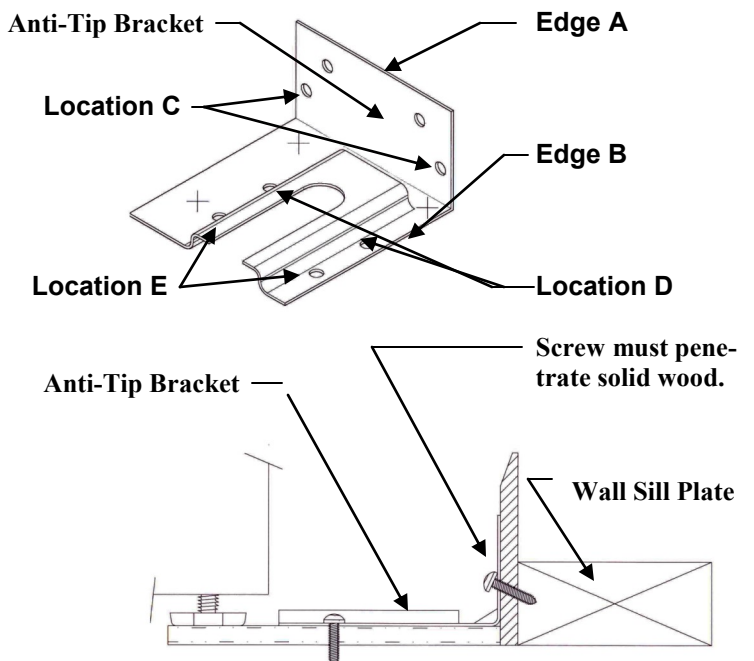

**NOTE:** The bracket should engage the right rear leg leveler.

**WARNING: IF RANGE IS EVER MOVED TO A DIFFERENT LOCATION, THE ANTI-TIP BRACKET MUST ALSO BE MOVED AND INSTALLED WITH THE RANGE.**

## CONNECTING THE RANGE TO GAS

The installation of this gas range must conform with the local codes, or in the absence of local codes, with the National Fuel Gas Code, ANSI Z223.1- "Latest Edition" in the U.S.A.

The installation of this gas range in a manufactured (mobile) home must conform with the Manufactured Home Construction and Safety Standard, Title 24 HUD (Part 280) or, when such standard is not applicable, the Standard for Manufactured Home Installations ANSI A225.1/NFPA 501A or with local codes.

The inlet pipe connection is a ½" National Pipe Tread. The gas connection can be made using an AGA or CGA design certified flex connector as illustrated below.

NOTE: When installed in the Commonwealth of Massachusetts the Flexible Connector used to supply gas to the range **must not exceed 36 inches in length** and a **T-Handle Gas Shutoff is required**.



**WARNING: A MANUAL SHUT-OFF VALVE MUST BE INSTALLED IN AN ACCESSIBLE LOCATION IN THE GAS LINE, EXTERNAL TO THE UNIT, FOR THE PURPOSE OF TURNING ON OR SHUTTING OFF GAS TO THE UNIT. THE CONSUMER MUST KNOW HOW AND WHERE TO SHUT OFF**



**WARNING: TO AVOID THE RISK OF A GAS LEAK OR FIRE, USE ONLY A NEW FLEXIBLE CONNECTOR THAT HAS BEEN DESIGN CERTIFIED BY AGA OR CGA. DO NOT REUSE AN OLD CONNECTOR IF YOU MOVE THE APPLIANCE.**



**WARNING: DO NOT ALLOW THE REGULATOR TO TURN ON THE PIPE WHEN TIGHTENING FITTINGS.**



**WARNING: USE AN APPROVED SEALING COMPOUND THAT IS RESISTANT TO THE AC-**

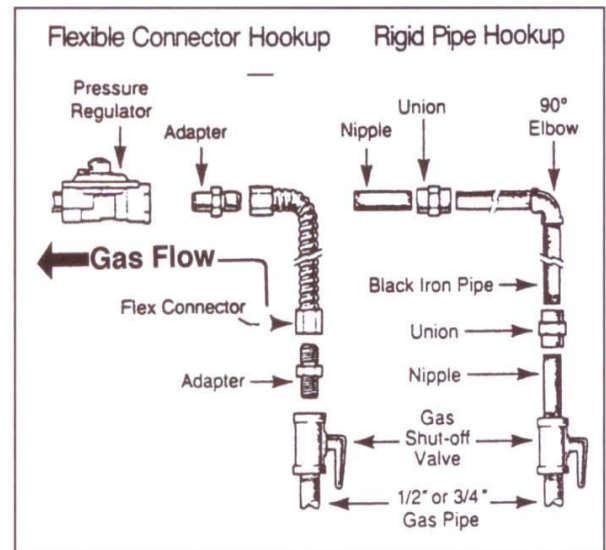

## GAS PRESSURE REGULATOR

This gas range is equipped with a convertible gas regulator that is adjusted at the factory for use with natural gas with 5 inches water column pressure at the outlet side of the regulator. With the regulator adjusted for use with liquefied petroleum gas (propane), the pressure at the outlet side of the regulator is 10" water column.

When checking the pressure regulator setting, the inlet pressure to the regulator must be at least 6 inches water column for natural gas and 11 inches water column for liquefied petroleum gas (propane). **The maximum inlet pressure to the regulator is 14 inches water column for natural or L.P. (propane) gases.**



# INSTALLATION INSTRUCTIONS

## TESTING FOR GAS LEAKS

**▲WARNING: DO NOT USE A FLAME TO CHECK FOR GAS LEAKS**

Before turning on the gas, be sure that all range valves are in the "OFF" position. Turn on the gas and check each joint or connection with a soap and water solution, including the inlet and outlet sides of the regulator. **Never test for leaks with a lighted match or open flame.**

- \* **THE APPLIANCE MUST BE ISOLATED FROM THE GAS SUPPLY PIPING SYSTEM BY CLOSING ITS INDIVIDUAL MANUAL SHUT-OFF VALVE DURING ANY PRESSURE TESTING OF THE GAS SUPPLY PIPING SYSTEM AT TEST PRESSURES EQUAL TO OR LESS THAN 1/2 PSIG (3.5 kPa).**
- \* **THE APPLIANCE AND ITS INDIVIDUAL SHUT-OFF VALVE MUST BE DISCONNECTED FROM THE GAS SUPPLY PIPING SYSTEM DURING ANY PRESSURE TESTING OF THAT SYSTEM AT TEST PRESSURES IN EXCESS OF 1/2 PSIG (3.5 kPa).**

## CONNECTING THE RANGE TO ELECTRICITY (SOME MODELS)

**Electrical Requirements:** 120-volt, 60 Hertz, properly grounded branch circuit protected by a 15-amp. or 20-amp. circuit breaker or time delay fuse.

**IMPORTANT:** Please read this section carefully. **FOR PERSONAL SAFETY, THIS APPLIANCE MUST BE PROPERLY GROUNDED.**

## GROUNDED

This range must be electrically grounded in accordance with local codes, or in the absence of local codes, with the National Electrical Code, ANSI/NFPA No 70-"Latest Edition".

An external electrical house current is required to operate the electrical parts of your range. The range cord has a three prong plug and must be used with a properly grounded three hole outlet. If such an outlet is not available, have a qualified electrician change your present outlet or install a new one.

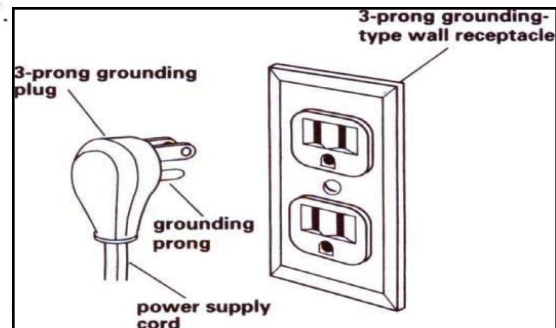

**▲ WARNING: TO AVOID THE RISK OF ELECTRICAL SHOCK, BURNS OR SERIOUS PERSONAL INJURY THIS UNIT MUST BE PROPERLY GROUNDED AND PLUGGED INTO A PROPERLY GROUNDED THREE-PRONG WALL RECEPTACLE. DO NOT UNDER ANY CIRCUMSTANCES CUT OR REMOVE THE GROUNDING PRONG FROM THE RANGE CORD. FAILURE TO PROVIDE PROPER POLARIZATION MAY CREATE A HAZARDOUS CONDITION.**

Have a qualified electrician verify that the outlet meets all requirements. Remember to disconnect power at the main circuit breaker and remove the electrical plug from the outlet before repairing any electrical component of your range. When removing the plug, grasp the plug, not the cord.

# INSTALLATION INSTRUCTIONS

## **POWERING CORDLESS RANGES (SOME MODELS)**

It is not necessary to connect your range to a plug-in outlet in your home. The burner ignition comes from a DC source (battery power pack).

### **INSTALLING THE DC POWER PACK**

Before any of the burners can be lighted, it is necessary to locate the power pack that is located in the range oven section. The power pack requires (8) AA size batteries. It is recommended that a good quality Alkaline Battery be used. Insert the batteries as described on the case. After loading the battery pack, insert the pack into the battery case located at the lower front corner of the range. Screw the power supply cover to the battery case with the screws provided. Do not over tighten.

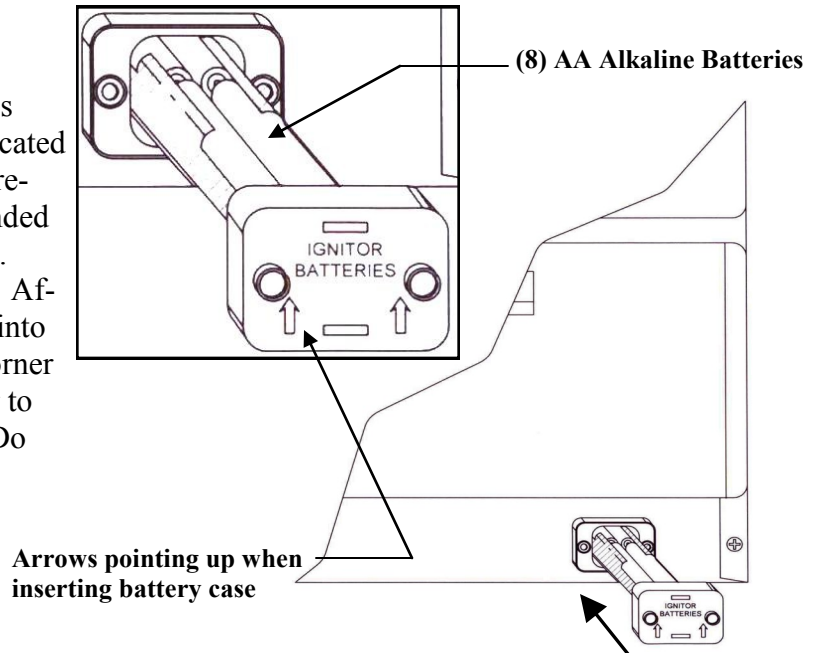

## **LOW BATTERY AUDIBLE SIGNAL**

Under normal use a good alkaline battery will provide 2 to 3 years of battery life. Because battery shelf life is limited, the battery life may vary.

Your range is equipped with a low battery audible signal. The battery warning tone will be heard whenever a burner is initially turned on. As soon as the burner knob is moved from the LITE position the audible signal will stop until the next time the burner is lit.

The low battery signal is an indicator that the batteries should be replaced soon. The range will continue to light and operate normally. The audible tone will continue to become louder and more consistent each time the range is used providing an occasional reminder that the batteries need replaced. Eventually the batteries will fail. It is a good idea to replace them as soon as possible after the audible signal is heard.

## **REPLACING WEAK BATTERIES**

1. Remove two screws holding battery case/cover in place. Note: The battery case is located in the front lower corner of the range.
2. Slide the cover/case out of the unit.
3. Replace the weak batteries with (8) fresh Double A Alkaline type batteries paying note to the battery instructions printed on the case.
4. Slide the case back into the unit with the arrows on the case cover facing up.
5. Replace two screws holding cover in place.

# CONVERTING RANGE FROM NATURAL GAS TO L.P. (PROPANE) GAS

**IMPORTANT: READ PRIOR TO STARTING THE CONVERSION PROCESS:** Because your range may be fitted with one of three different types of oven systems, it is necessary to determine which system the range employs in order to be successful making the range conversion. These instructions provide two different methods for converting the range from Natural Gas to LP (Propane) Gas, **Method A** or **Method B**. Use the following guidelines to determine which method to use for conversion:

- If the range has a “PILOT” or “LITE” setting on the oven thermostat control use **Method A**.
- If the range does not have a “PILOT” or “LITE” setting on the oven thermostat control use **Method B**.

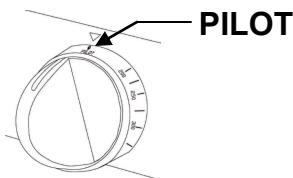

**WARNING: TO AVOID THE RISK OF SERIOUS PERSONAL INJURY OR PROPERTY DAMAGE, THE RANGE MUST BE CONVERTED CORRECTLY. IMPROPER CONVERSION OR FLAME ADJUSTMENT WILL PRODUCE CARBON MONOXIDE, WHICH IS A POISONOUS GAS.**

**LOCATING PRESSURE REGULATOR:** From back of range, locate the pressure regulator at the gas inlet to the unit.

## STEP 1 METHOD A or METHOD B Convert Regulator from Nat. Gas to LP Gas:

This oven system will have the regulator shown in Figure 1 or Figure 2

- Remove cap from regulator and snap out plastic plunger from bottom of cap.
- Turn plunger over and snap back into the same location.
- Re-insert cap into regulator and screw in place.

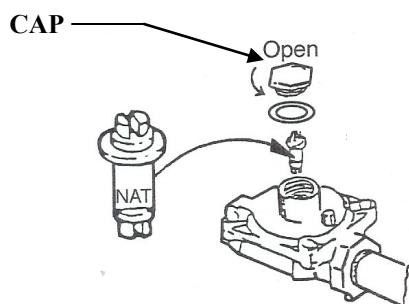

NATURAL GAS POSITION

Fig. 1

REGULATOR

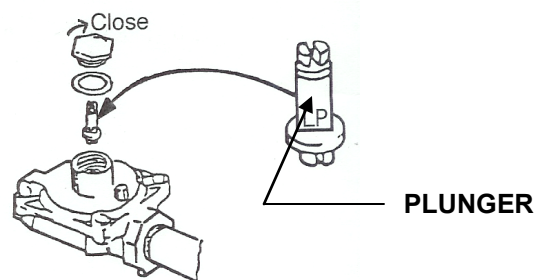

LP GAS POSITION

- Use a coin to remove the cap from the pressure regulator. See Fig 2
- Turn the cap over and engage it in the slots. LP should now be visible on the top of the cap.

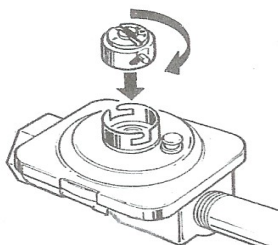

NATURAL GAS POSITION

**NOTE:** The type of gas you are converting to must be visible on the cap.

Fig. 2

REGULATOR

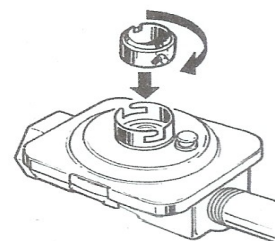

LP GAS POSITION



# CONVERTING RANGE FROM NATURAL GAS TO L.P. (PROPANE) GAS

## STEP 2 METHOD A or METHOD B Convert top burners:

To convert burners from Natural Gas to L.P. (propane) the burner orifices must be replaced with a set of orifices packed separately with the unit.

- Remove the burner caps. This requires no tools.
- Remove the Natural Gas orifice by reaching down into the center of the burner with a 5/16" nut driver.
- Rotate the orifice counter-clockwise to remove and replace with the proper L.P. replacement.
- Use the description to identify the proper orifice for the proper size burner.

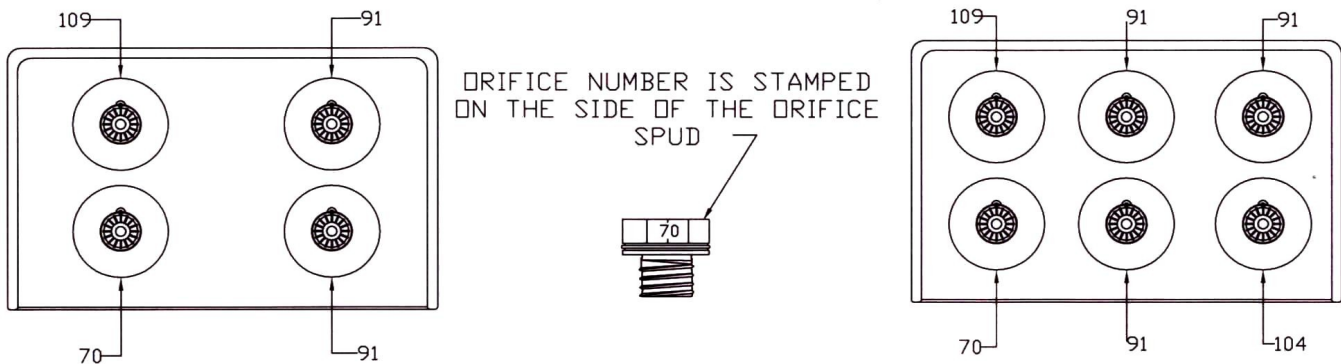

## STEP 3 METHOD A Convert the Range Oven thermostat.

The oven thermostat control is at the center front of the range located behind the oven control knob and control panel. Locate the brass LP (propane) gas conversion screw on the right side of the oven thermostat as shown in Fig. 4. This screw can be accessed through a hole in the control panel.

- Turn the conversion screw clockwise until seated tight into the oven thermostat control.
- After the conversion screw has been converted, the oven pilot flame must be adjusted. In order to properly set the pilot it is necessary to remove the oven bottom (See page 11 for the oven bottom removal).

**OVEN THERMOSTAT CONTROL**  
(located behind the oven control knob and control panel)

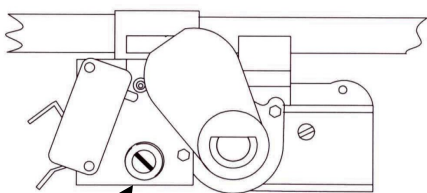
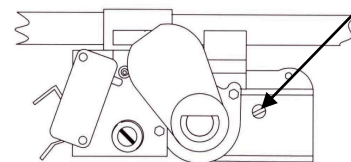

Fig. 5

PILOT ADJUSTMENT SCREW

GAS CONVERSION SCREW

Fig. 4



**OVEN THERMOSTAT CONTROL**  
(located behind the oven control knob and control panel)

- Remove the oven burner baffle by removing the wing nut that holds the baffle to the oven burner. With the baffle removed, the oven pilot can be observed on the right rear side of the oven burner.
- Before adjusting the oven pilot, the pilot has to be lit. In order to light the oven pilot, rotate the control knob to the "PILOT" or "LITE" position and push and hold in on the knob. Hold knob for approximately 10 sec. before releasing it. The pilot should remain lit. Repeat step 4 if pilot goes out.

# CONVERTING RANGE FROM NATURAL GAS TO L.P. (PROPANE) GAS

5. Once the pilot is lit, locate the pilot adjustment screw on the lower left hand side of the oven thermostat control. See Fig. 5. Access the pilot adjustment screw through the opening behind the oven temperature control knob. With a straight blade screwdriver rotate the screw till the outer tip of the flame is just barely reaching the underside of the end of the flame safety probe. See Fig. 6.

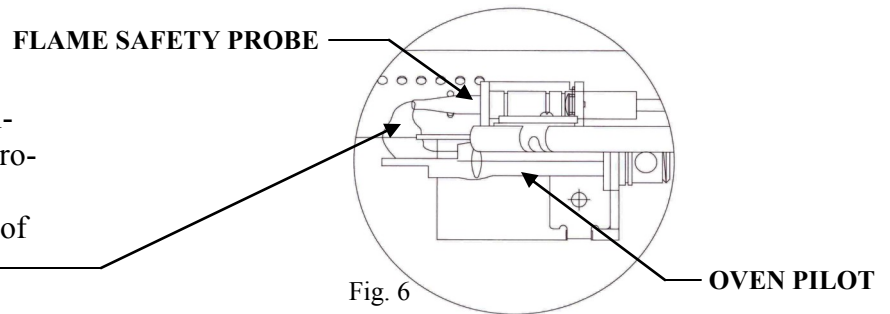

**STEP 3 METHOD B** No Oven Thermostat conversion is required.

**STEP 4 METHOD A or B** Convert Oven Burner:

The oven burner orifice is located beneath the inlet to the oven burner at the lower rear portion of the broiler section. ( See Fig. 7) Using a 1/2" wrench turn the orifice hood clockwise until it is snug.

**Warning:** Do not over-tighten the orifice hood.

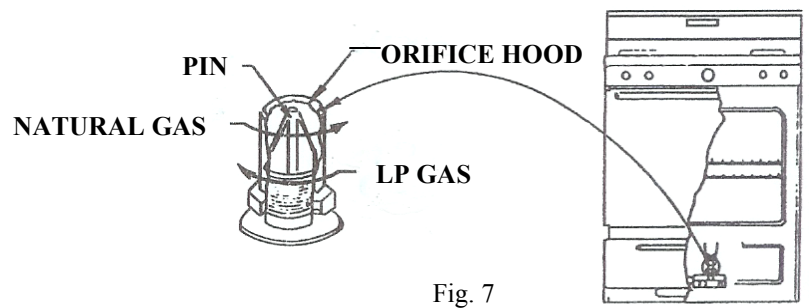

**STEP 6 METHOD A or METHOD B** Check Operation:

After the above conversion has been completed, check operation of the top burners and oven burner. Make air shutter adjustment in oven if necessary (See Page 26 for lighting and burner adjustments.).

# INSTALLATION INSTRUCTIONS

## CHECK SURFACE BURNER IGNITION

Simultaneously push in and turn a top burner knob to the LITE or START position. You will hear a clicking sound indicating the proper operation of the spark module. Once the air has been purged from the supply lines, the burner will light. Rotate the knob out of the LITE or START position after the burner lights. Try each burner in succession until all burners have been checked.

## TOP BURNER LOW FLAME ADJUSTMENT

Each top burner can be adjusted separately to allow for varied low temperature setting across the top burner cooking section. To adjust the low setting:

1. Remove the top burner control knob for the burner that you wish to adjust.
2. With a small straight blade screwdriver access the low setting adjustment screw located in the center of the stem of the burner control knob.
3. With the burner turned on to the low setting rotate the screw to adjust the burner down to the desired setting. When adjusted to the minimum flame the burner should maintain a constant blue flame across all of the top burner ports. This procedure can be repeated for each top burner if desired.

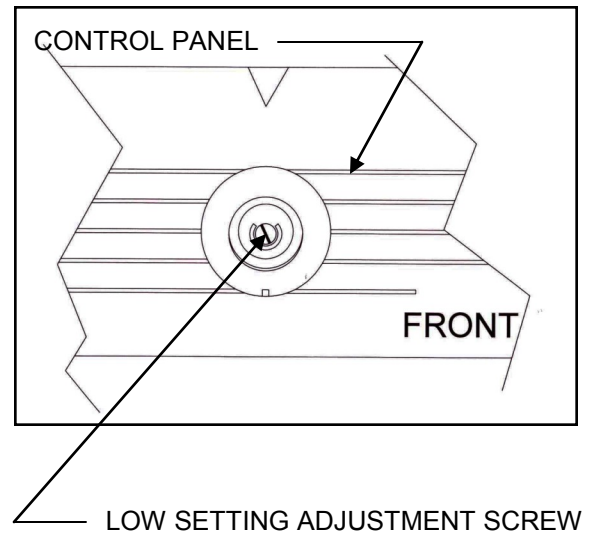

## CHECK OVEN BURNER IGNITION

- If the range has a “PILOT” or “LITE” setting on the oven thermostat control use the following method for testing the oven burner ignition.

Push and turn the oven control counterclockwise to the “PILOT” or “LITE” position. Once in the PILOT or LITE position, push in on the knob as far as possible and hold for 10 seconds. After the 10 second elapsed period, release the oven control knob. See note below. The pilot flame will remain lit. Select the cooking temperature by pushing and turning the oven control knob to the desired temperature. Open the oven door and observe that the burner flame is lit by looking through the observation hole in the front center of the oven bottom. When the selected temperature is reached the oven burner flame will reduce in size and hold the oven temperature steady at the desired setting.

**NOTE: THE FIRST TIME YOUR OVEN IS USED IT MAY BE NECESSARY TO HOLD IN ON THE OVEN CONTROL KNOB FOR AS MUCH AS 60 SEC. TO ALLOW GAS TO FLOW THROUGH THE OVEN SYSTEM.**

- If the range does not have a “PILOT” or “LITE” setting or the word pilot on the oven thermostat control use **Method B.**

Turn the oven control knob to a setting above 300 F. After 30-60 seconds the oven burner will ignite and burn until the set temperature is reached. If your range employs an igniter for oven ignition, the burner will cycle off and on during the cooking process.



# INSTALLATION INSTRUCTIONS

## ADJUST AIR SHUTTERS, IF NECESSARY

### OVEN BURNER:

The air shutter adjustment for the oven burner is located at the open end of the oven burner venture tube and sits on the hood of the oven burner valve. To adjust air shutter:

1. Loosen the screw on the air shutter.
2. Move the air shutter closed to decrease or open to increase the amount of air to the flame.
3. When the flame is properly adjusted, tighten the screw.

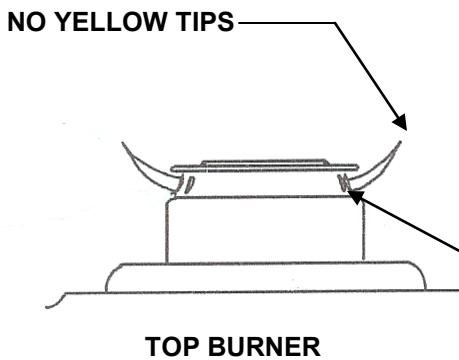
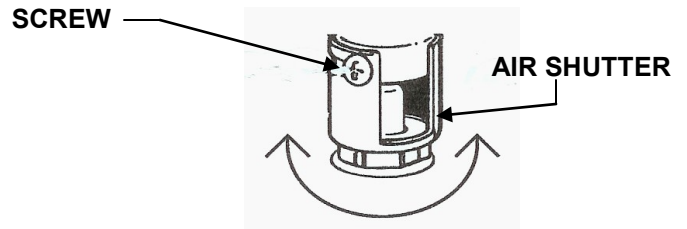

*The burner flame should be a steady blue. A burner with a yellow flame, unsteady flame, or a partial flame is in need of an air shutter adjustment.*

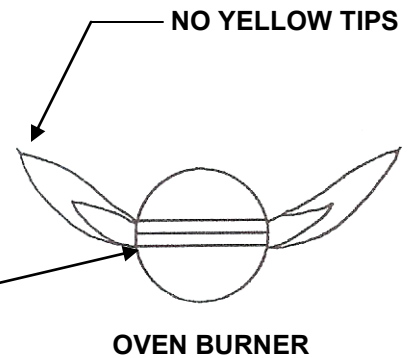

NO LIFTING

# WIRING DIAGRAMS

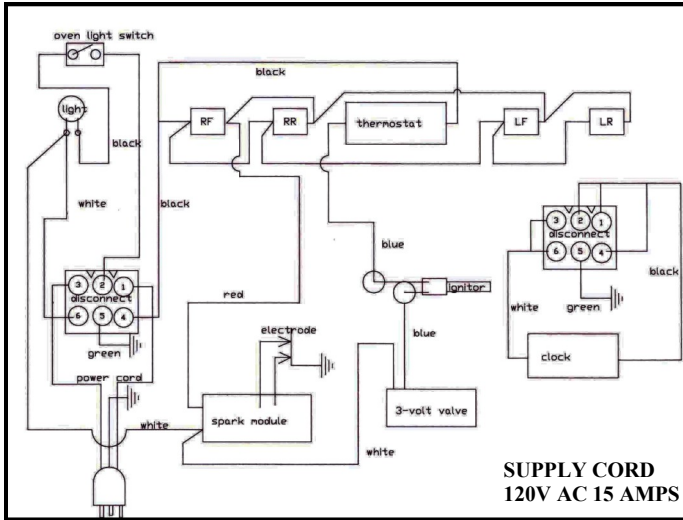

**HOT SURFACE IGNITION SYSTEM**

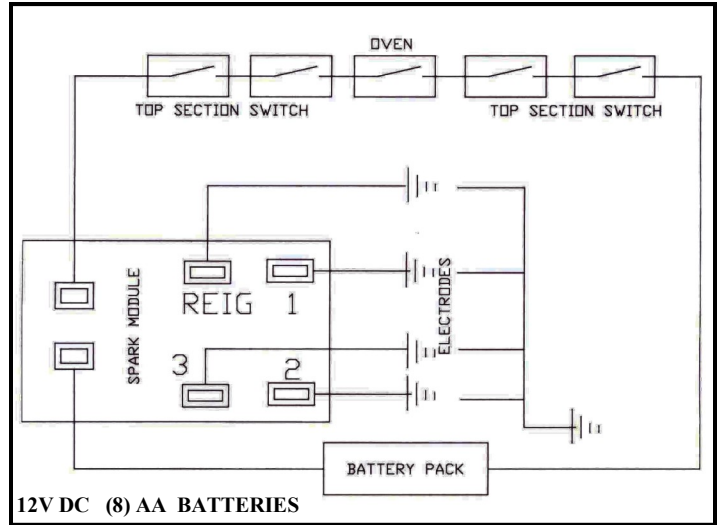

**BATTERY IGNITION SYSTEM**

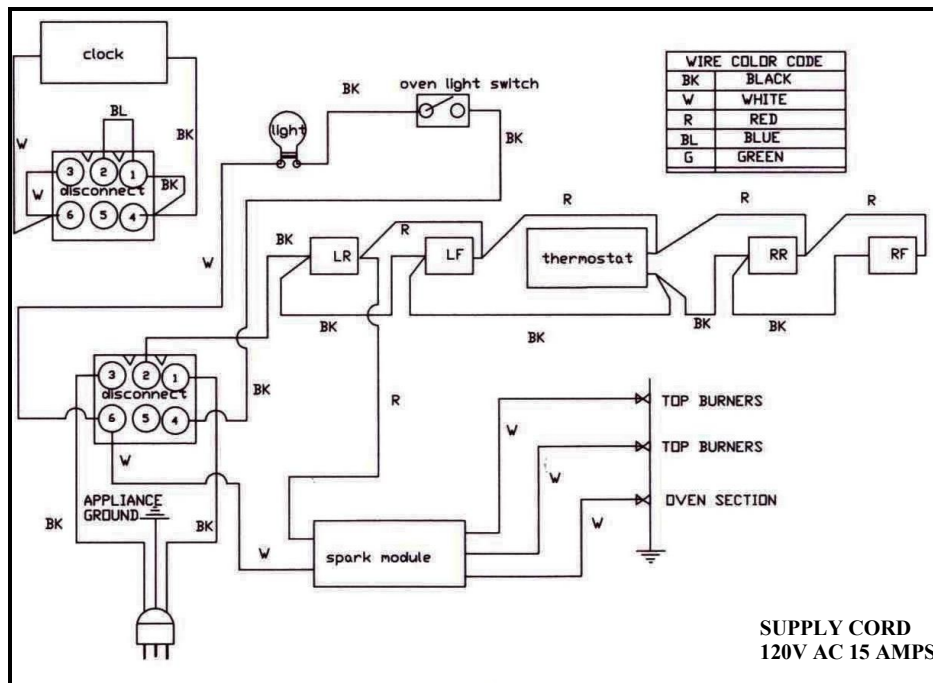

**SPARK/THERMOCOUPLE IGNITION SYSTEM**

# BEFORE YOU CALL FOR SERVICE

Before you call for service, review this list. It may save you time and expense. This list includes common occurrences that are not the result of defective workmanship or materials in this appliances.

*Find your problem here*

*Possible cause*

*How to fix it*

## SURFACE BURNERS

**Surface burners do not light.**

Range power cord is disconnected from the outlet.

Be sure power cord is plugged into grounded outlet.

Electrical power outage.

Burners can be lit manually. See “Operating your range during an electrical power failure” section.

Batteries dead, missing or improperly installed.

Check that the range power pack has fresh batteries and that they are installed as described on the battery pack.

Surface control has not been completely turned to the LITE or START position.

Push in and turn control to the LITE or START position until burner ignites, then turn control to desired flame setting.

Burner ports are clogged.

Use a small gauge wire or needle to open ports or clear slotted ports.

Burner ports are clogged.

Use a small gauge wire or needle to open ports or clear slotted ports.

**Flame burns half-way around**

Moisture is present after cleaning.

Lightly fan the flame and allow burner to operate until flame is full.  
Dry burners thoroughly following instructions in range “Cleaning” section.

**Flame is orange.**

Range improperly converted.

Correct conversion by following instructions on Pages 22-24 in this manual.



# BEFORE YOU CALL FOR SERVICE

## *Find your problems here*

continued:

**Flame is orange.**

## *Possible cause*

Dust particles in main line.

## *How to fix it*

Allow burner to operate for a few minutes until flame turns blue. Make sure temperature control is set at the desired temperature.

## **OVEN AND BROILER**

**Oven or broiler does not heat.**

House fuse has blown or circuit breaker has tripped.

Check/reset circuit breaker and/or replace fuse.

Electrical power outage.

Oven can be lit manually. See “Operating your range during an electrical power failure” section.

Is the power cord unplugged.

Plug into a grounded outlet.

Are batteries properly installed in the battery power pack.

Check that the range power pack has fresh batteries and that they are installed as described on the battery pack.

**Oven temperature inaccurate**

Oven capillary bulb not set properly.

Verify that capillary bulb is snapped in clips straight and not touching sides or coated with oven cleaner or food.

Temperature control not set properly.

Make sure the temperature control knob is set at the desired temperature.

Improper use of foil.

Keep foil clear of holes in oven bottom and off of oven racks.

Vent blocked.

Keep vent at front of backguard clear.

Improper range conversion.

Correct conversion by following instructions on Pages 21-23 in this manual.

# BEFORE YOU CALL FOR SERVICE

<i>Find your problems here</i>	<i>Possible cause</i>	<i>How to fix it</i>
<b>Nuisance sparking while oven is in operation.</b>	Improperly grounded or reversed polarity electrical outlet.	Have outlet corrected by a qualified electrician.
<b>Smoke or odor on initial oven operation.</b>	This is normal.	This will stop after the range has been heated the first time.
<b>Persistent smoke or odor.</b>	Range improperly converted.	Correct conversion by following instructions on Pages 21-23 in this manual.

## **INSTALLATION**

Range not level.	Poor installation.	Place oven rack in center of oven. Place a level on the oven rack. Adjust leveling legs.
	Weak unstable floor.	Be sure floor is level and can adequately support range.

## **BROILING**

Oven smokes excessively.	Meat too close to broiler burner.	Reposition the broiler pan to provide more clearance between the meat and the broiler burner. (See broiler section.)
	Broiler drawer needs to be cleaned.	Excessive smoking is caused by old grease or food spatters. If the broiler is use often, clean on a regular basis.

Dear Homemaker:

Your range will give you years of satisfactory service and pleasure when properly cared for and used. Producing an efficient range that conserves energy requires a considerable investment of time, effort and money.

Your range is engineered to surpass all performance and safety requirements. However, safety is also YOUR responsibility through proper use and care.

With this in mind, it is important that you read this booklet. Acquaint yourself with features and follow the use and care suggestions for complete satisfaction.

## MODEL AND SERIAL NUMBER LOCATION

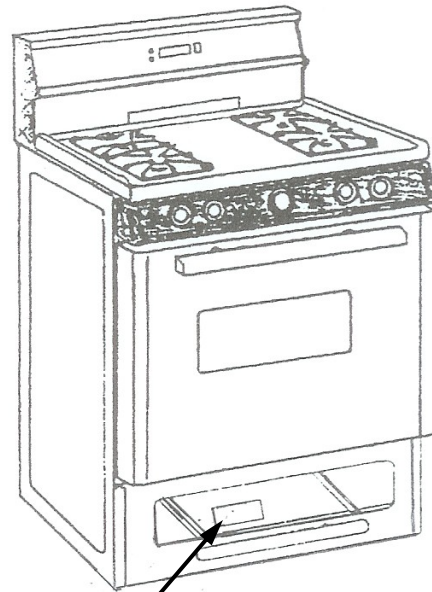

**MODEL NUMBER**

**SERIAL NUMBER**

- Should it be necessary to order parts, always include the COMPLETE MODEL NUMBER AND SERIAL NUMBER to insure receiving the correct parts.
- The model and serial number is on the serial number plate located beneath the broiler carriage. (See page 10 for the broiler carriage removal.)

For questions concerning parts or service, refer to the enclosed limited warranty certificate. If you need assistance, call us at 1-800-858-5844 or contact us at [www.premier.com](http://www.premier.com)

### RECORD HERE FOR EASY REFERENCE:

Range Model Number \_\_\_\_\_ Color \_\_\_\_\_

Range Serial Number \_\_\_\_\_

Installation Date \_\_\_\_\_

Dealer's Name and Address \_\_\_\_\_

See our entire product line at:  
[www.PremierRange.com](http://www.PremierRange.com)