

SPARE PARTS CATALOG

OFFICE PRO 63



MOVINCOOL®
THE #1 SPOT COOLING SOLUTION

Table of Contents

No.	UNIT PART NUMBER	PRODUCTION PERIOD	REFRI-GERANT	SECTION	ISSUE DATE (mm/yy)
1	GX484000-3860	FROM January 2008 (0108) TO Present	R410A	SP0011-01 page 3 ~ 15	06/15

© 2015 DENSO SALES CALIFORNIA, INC.

All rights reserved. This book may not be reproduced or copied, in whole or in part, without the written permission of the publisher. DENSO SALES CALIFORNIA, INC. reserves the right to make changes without prior notice. MovinCool is a registered trademark of DENSO Corporation.

OFFICE PRO 63

Unit Part No: GX484000-3860

Production Period: From January 2008 (0108)
To Present

OFFICE PRO 63

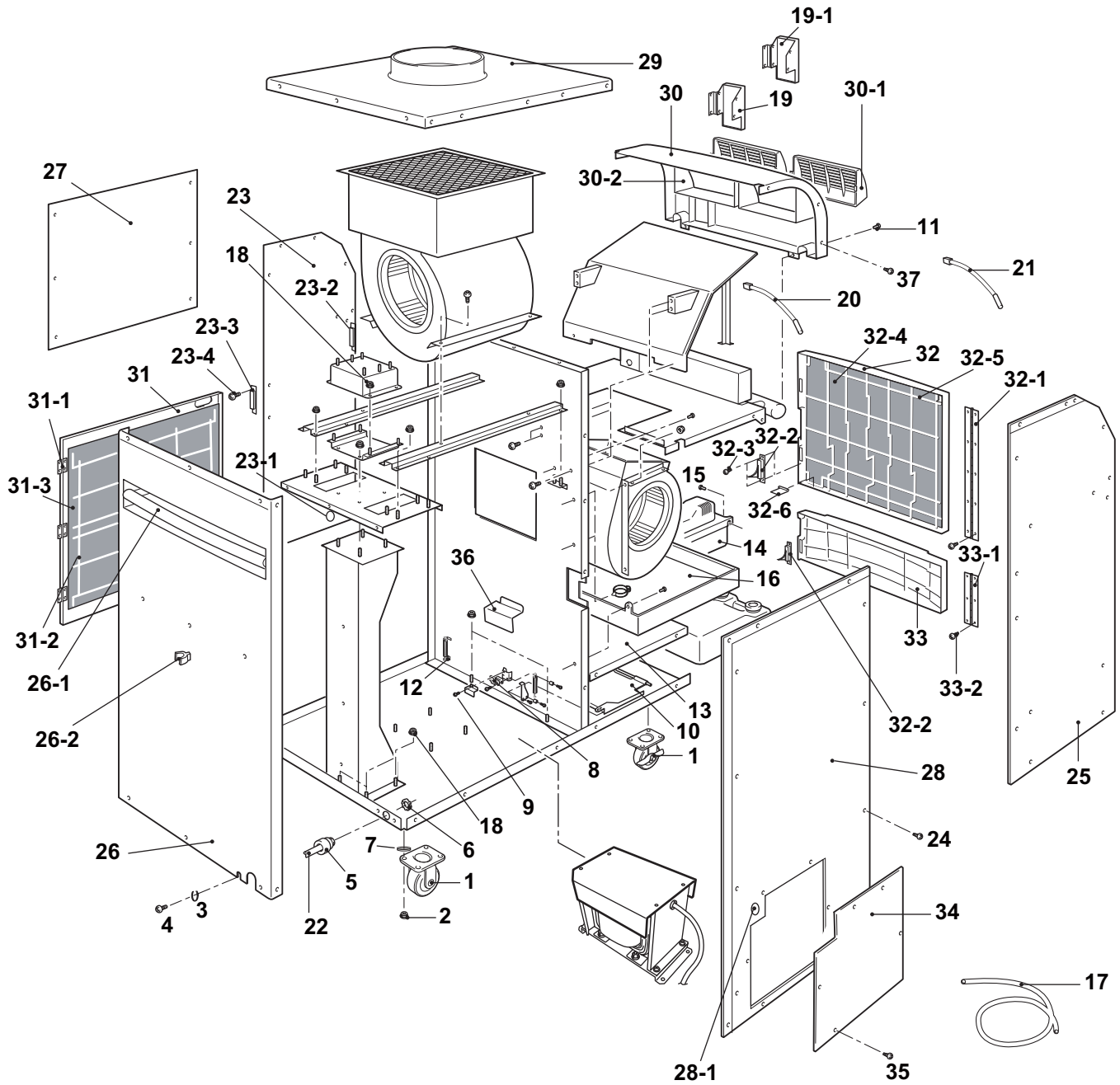

OFFICE PRO 63

ILL. NO.	DESCRIPTION	PART NO.	QTY.	MODIFICATION DATE (mm/yy)	REMARKS
1	Caster w/Brake	LA484702-0350	4		
2	Nut	LA480929-0140	16		M10×1.5
3	Washer, Plate	90201-06400	1		Ground
4	Screw	90051-06120	1		Ground (M6×1, L=12)
5	Connector (Retainer, Power Cord)	GX484784-0050	1		
6	Nut, Holder (Retainer, Power Cord)	LA484919-0090	1		
7	Plate	LA484311-2440	16		
8	Switch, Drain Tank	LA484502-0380	1		For Drain Tank
9	Screw w/Washer	91310-03161	2		M3×0.5, L=16
10	Frame Assy	LA484300-1650	1		
11	Screw	949006-5850	34		M4×0.7, L=10
12	Clip	484917-0280	2		
13	Frame Assy	LA484300-1662	1		
14	Pump Assy	GX484780-0220	1		
15	Screw w/Washer	91370-04101	2		M4×0.7, L=10
16	Pan Assy, Drain	GX484430-0610	1		Drain Pan
17	Hose, Drain	LA484432-018B	1		
18	Nut	949056-1430	17		M6×1
19	Switch Assy	GX484560-2040	1		Operation Panel & PCB w/ILL.NO.19-1
19-1	Cover Assy	GX484420-0540	1		Operation Panel
20	Thermistor, Room Temperature	LAY84532-0021	1		
21	Thermistor, Anti-Freeze Up	LA484532-0041	1		
22	Wire Assy, Power Cord	GX484930-9800	1		
23	Panel Assy, Right Front	GX484410-8190	1		w/ILL.NO.23-1~23-4
23-1	Grommet	LA484926-0500	1		
23-2	Catch	LA481922-0030	3		
23-3	Holder (Magnet Type)	484927-0990	2		
23-4	Screw	949006-4440	4		M3×0.5, L=8
24	Bolt	LA480919-0290	69		M6×1, L=10
25	Panel Assy, Left Front	GX484410-8200	1		
26	Panel Assy, Rear	GX484410-8210	1		w/ILL.NO.26-1~26-2
26-1	Handle	LA484451-0080	1		
26-2	Clip	LA484917-042A	2		For Power Cord
27	Panel Assy, Right Top Rear	GX484410-8220	1		
28	Panel Assy, Left Rear	GX484410-8820	1		w/ILL.NO.28-1
28-1	Grommet	GX484926-0700	1		
29	Panel Assy, Top	GX484410-8240	1		
30	Panel Assy, Top Front	LA484410-6021	1		w/ILL.NO.30-1~30-2
30-1	Air Louver, Outlet	LA480431-0101	2		
30-2	Pin	LA484913-0070	6		

OFFICE PRO 63

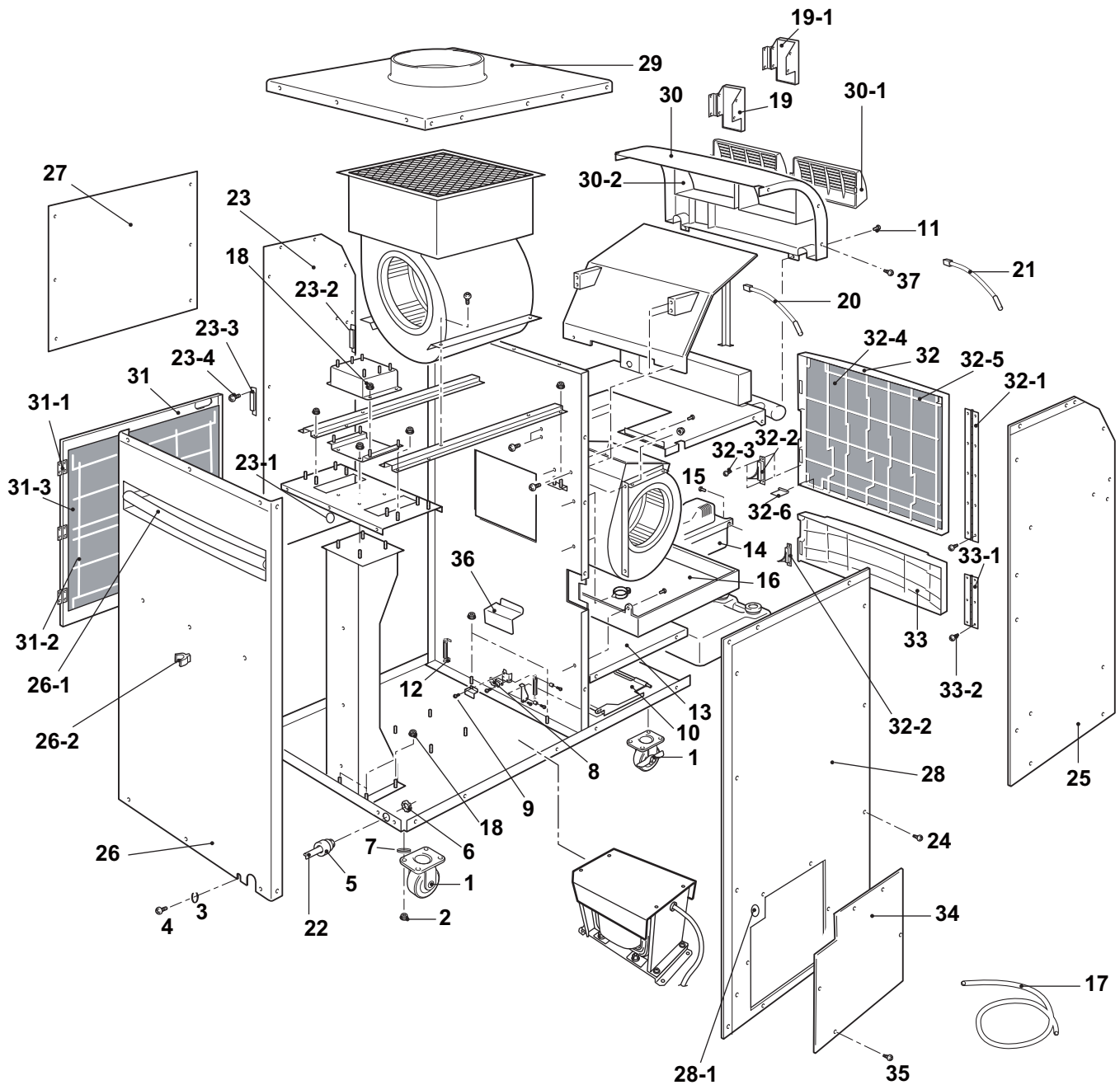

ILL. NO.	DESCRIPTION	PART NO.	QTY.	MODIFICATION DATE (mm/yy)	REMARKS
31	Panel Assy, Side Filter	GX484410-8250	1		w/ILL.NO.31-1~31-3
31-1	Hinge	GX484912-0100	1		For Condenser Panel
31-2	Filter (Condenser)	GX484401-1680	1		
31-3	Wire Frame (Condenser)	GX484301-4730	1		
32	Panel Assy, Front Filter	LA484410-6041	1		w/ILL.NO.32-1~32-6
32-1	Hinge	LA484912-0062	1		For Evaporator Panel
32-2	Holder	LA484927-1010	3		Door Hook
32-3	Screw, Tapping	LA949001-1730	12		D4, L=16
32-4	Filter (Evaporator)	LA484401-1310	1		
32-5	Wire Frame (Evaporator)	LA484310-3430	1		
32-6	Clip	LAY84917-0050	2		Holder, Wire Frame
33	Panel Assy	LA484410-6051	1		Drain Tank Door w/ILL.NO.33-1~33-2
33-1	Hinge	LA484912-0071	1		For Drain Tank Door
33-2	Bolt	LA480919-0320	19		
34	Panel Assy, Service	GX484410-8830	1		
35	Screw w/Washer	480919-0370	9		M4×0.7, L=10
36	Cover Sub-Assy	LAY84390-0010	1		
37	Bolt	LA480919-0330	10		M6×1, L=12

OFFICE PRO 63

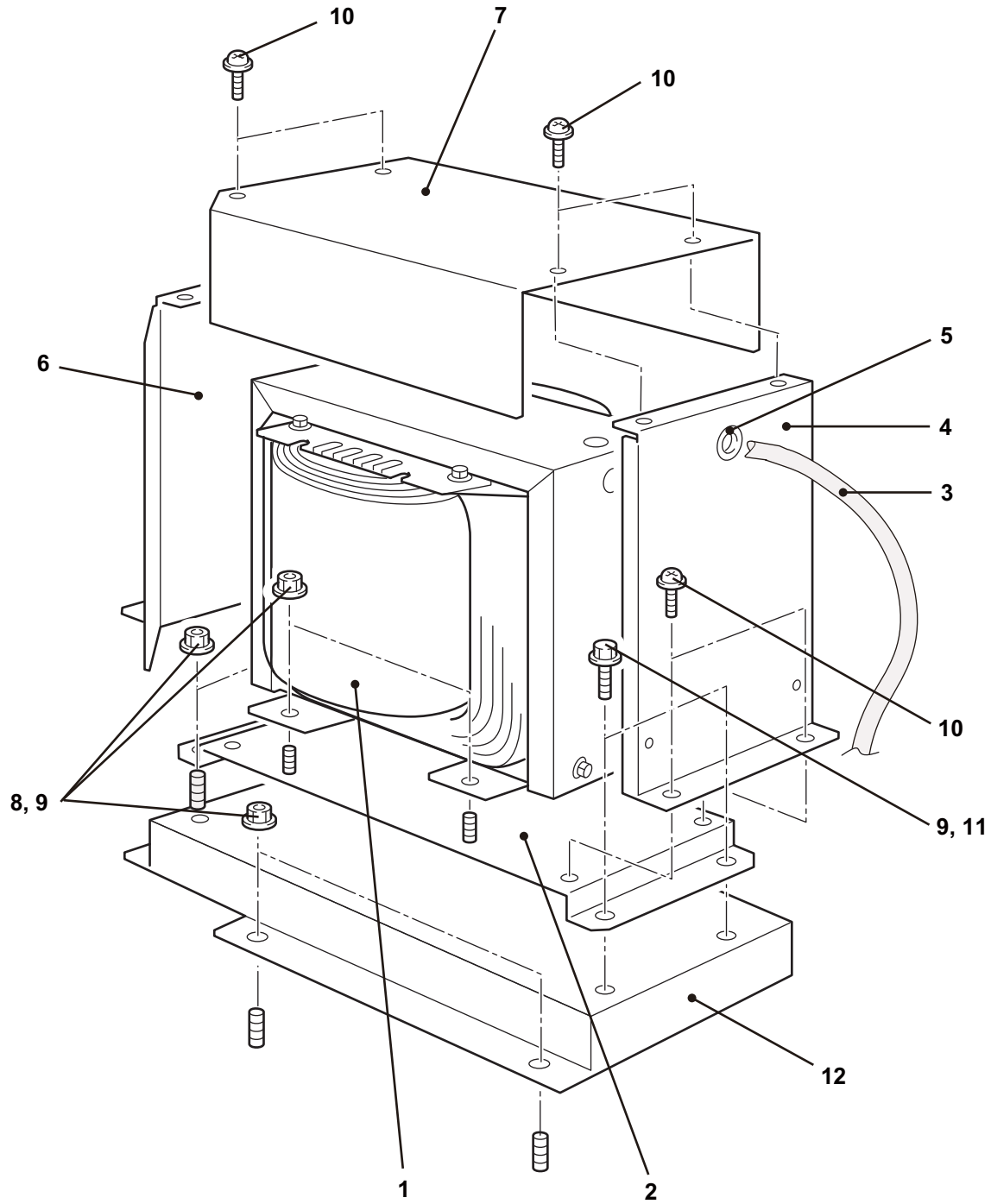

OFFICE PRO 63

ILL. NO.	DESCRIPTION	PART NO.	QTY.	MODIFICATION DATE (mm/yy)	REMARKS
1	Transformer Assy	GX484500-3520	1		5KVA
2	Stay Sub-Assy	GX484340-3070	1		
3	Wire Assy	GX484930-9752	1		
4	Bracket, Right	GX484321-3481	1		
5	Grommet	LA484926-0490	1		
6	Bracket, Left	GX484321-3471	1		
7	Bracket, Upper	GX484321-3490	1		
8	Nut	90190-08651	11		M8×1.25
9	Washer, Steel Plate	949011-5330	13		
10	Screw	949006-5850	8		M4×0.7, L=10
11	Bolt	91510-08141	2		M8×1.25, L=14
12	Stay Sub-Assy	GX484340-3080	1		

OFFICE PRO 63

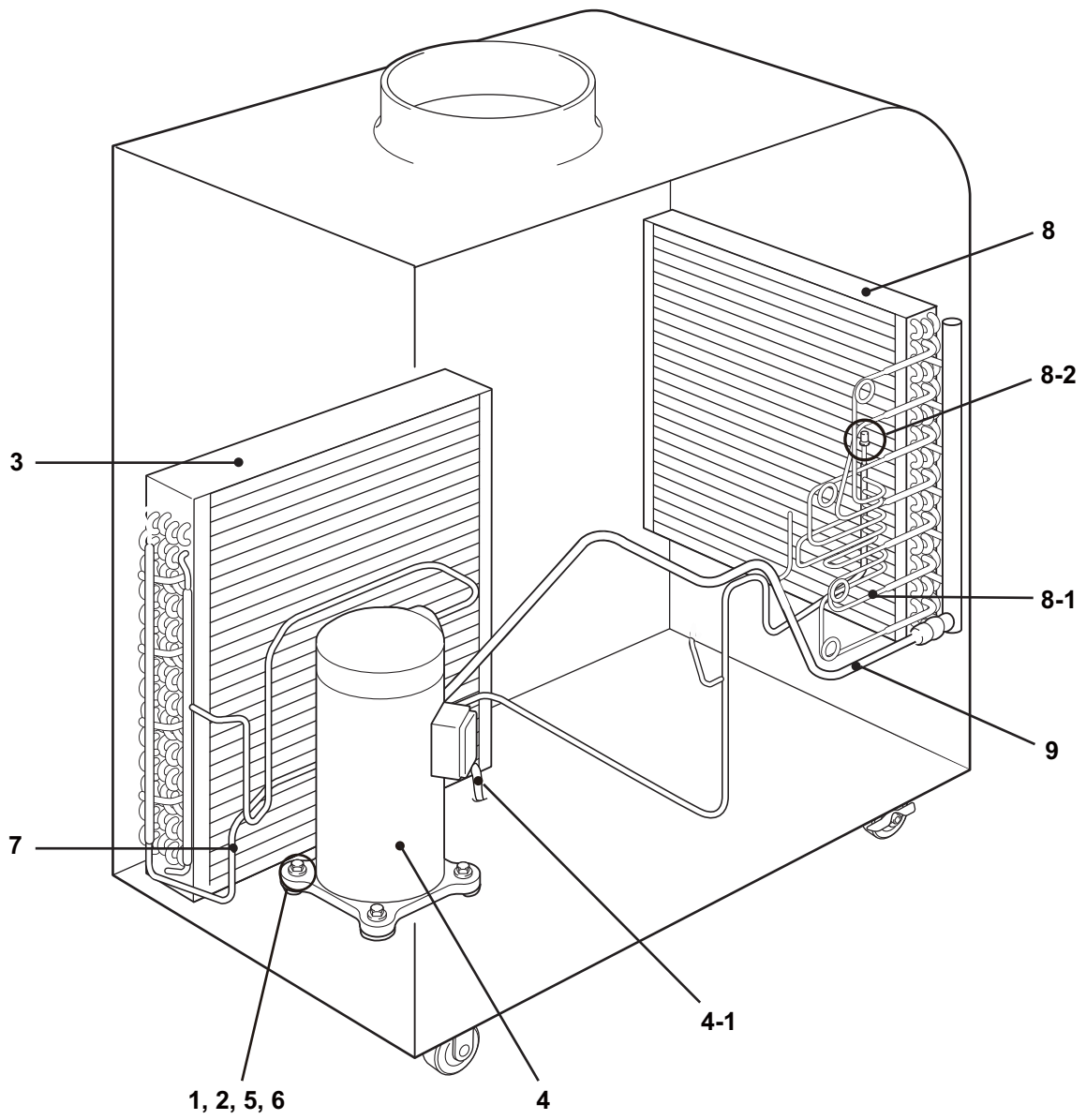

OFFICE PRO 63

ILL. NO.	DESCRIPTION	PART NO.	QTY.	MODIFICATION DATE (mm/yy)	REMARKS
1	Washer, Steel Plate	949011-5330	4		
2	Nut	90190-08651	4		M8×1.25
3	Core Assy, Condenser	GX484600-2140	1		
4	Compressor Assy	GX484650-2760	1		w/ILL.NO.4-1
4-1	Wire Assy	GX484930-9740	1		
5	Cushion	LA484904-0220	4		
6	Collar	LA484915-0280	4		
7	Pipe Assy, Connecting	GX484800-4360	1		For Discharge
8	Core Assy, Evaporator	GX484600-2160	1		w/ILL.NO.8-1~8-2
8-1	Pipe Assy, Capillary	GX484800-4110	1		
8-2	Switch Assy, Pressure	GX484660-0550	1		
9	Pipe Assy, Connecting	GX484800-4370	1		For Suction

OFFICE PRO 63

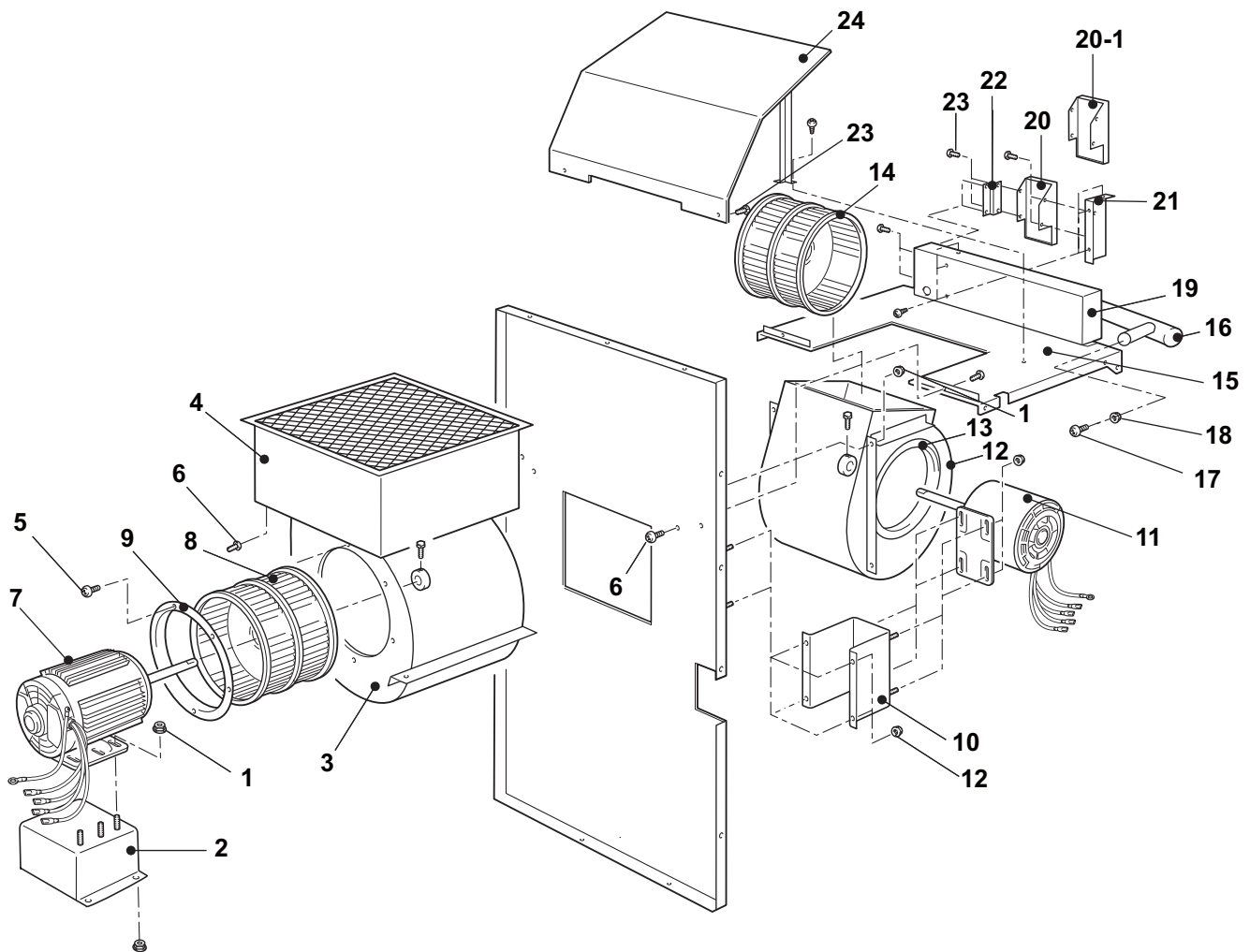

OFFICE PRO 63

ILL. NO.	DESCRIPTION	PART NO.	QTY.	MODIFICATION DATE (mm/yy)	REMARKS
1	Nut	949056-1430	26		M6×1
2	Motor Stay, Condenser	GX484330-0620	1		
3	Casing Assy, Condenser Fan	LA484260-0360	1		
4	Box Sub-Assy, Condenser	LA484520-0840	1		
5	Screw, Tapping	949001-1570	24		D4, L=10
6	Screw w/Washer	91370-06141	4		M6×1, L=14
7	Fan Motor, Condenser	LA484211-1501	1		
8	Fan, Condenser	LA484221-0450	1		w/Set Screw
9	Ring	LA484381-0540	2		For Condenser
10	Motor Stay, Evaporator	LA484330-053A	1		
11	Motor, Evaporator	LA484211-1492	1		
12	Casing Assy, Evaporator Fan	LA484260-0340	1		
13	Ring	LA484381-0530	2		For Evaporator
14	Fan, Evaporator	LA484221-0440	1		w/Set Screw
15	Frame Sub-Assy	LA484310-3420	1		
16	Handle, Front	LA484451-0080	1		
17	Bolt	LA480919-0300	2		For Handle M10×1.5, L=20
18	Washer, Spring	90258-10001	2		For Handle
19	Box Sub-Assy	LA484520-0820	1		
20	Switch Assy	GX484560-2040	1		Operation Panel & PCB w/ILL.NO.20-1
20-1	Cover Assy	GX484420-0540	1		Operation Panel
21	Stay, Control Panel Left	GX484340-3060	1		
22	Stay, Control Panel Right	GX484331-9380	1		
23	Screw	949006-5850	9		M4×0.7, L=10
24	Deflector, Air	LA484310-3450	1		

OFFICE PRO 63

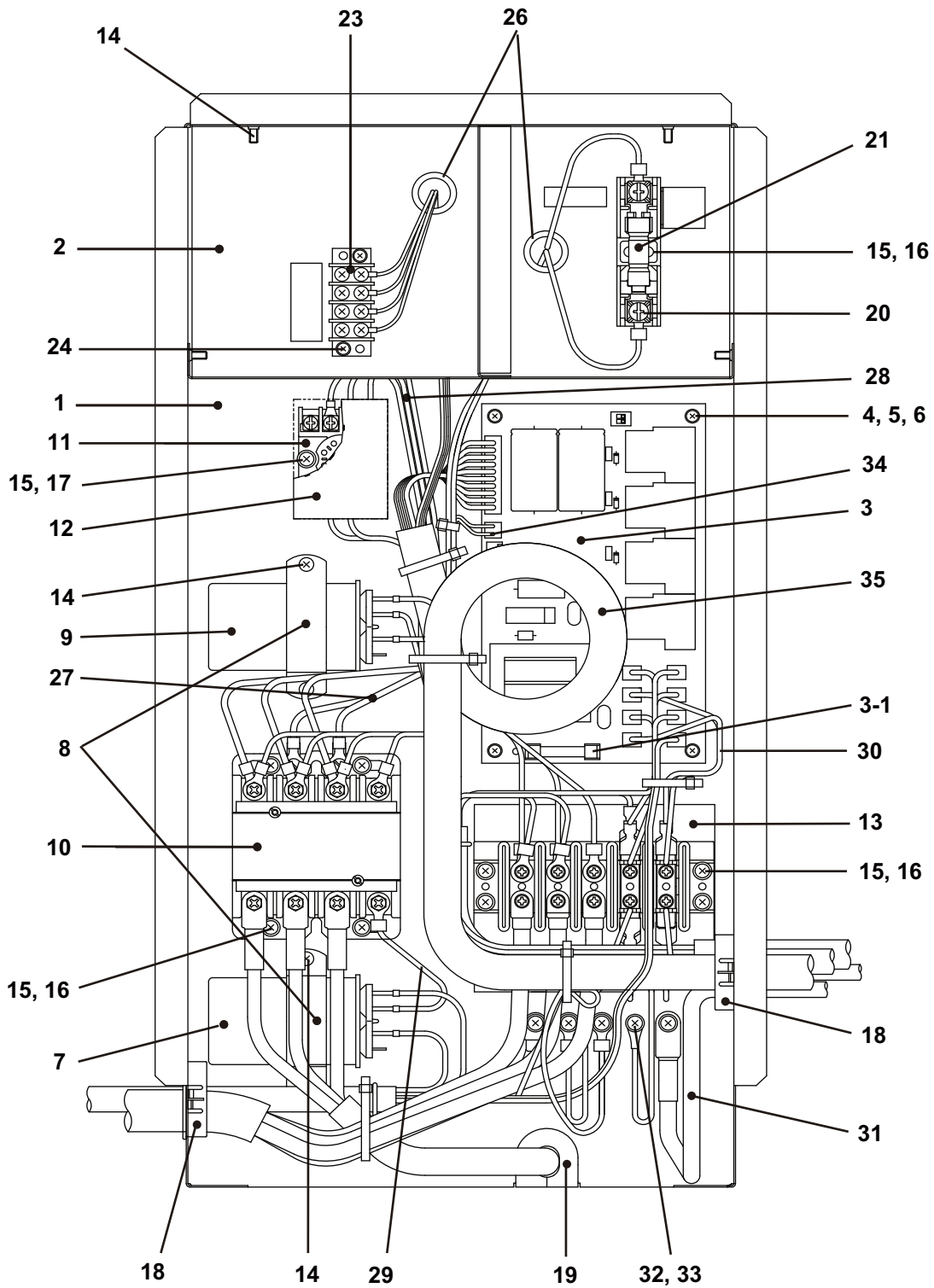

OFFICE PRO 63

ILL. NO.	DESCRIPTION	PART NO.	QTY.	MODIFICATION DATE (mm/yy)	REMARKS
1	Box Sub-Assy	GX484520-1130	1		
2	Bracket	GX484340-3092	1		
3	Relay Board	LA484500-2291	1		w/ILL.NO.3-1
3-1	Fuse, Relay Board	LAY65765-0010	1		200mA, 250V
4	Washer, Plate	90200-03211	5		
5	Spacer	LA484921-0150	5		
6	Screw w/Washer	91370-03081	5		M3×0.5, L=8
7	Capacitor, Condenser Fan	LA484507-1180	1		370VAC, 25uF
8	Holder	LA484927-0880	2		
9	Capacitor, Evaprator Fan	LA484507-1210	1		440VAC, 15uF
10	Relay, Compressor	GX484531-0871	1		
11	Terminal Block, Reverse Phase	GX484503-0900	1		
12	Relay, Reverse Phase	GX484531-0880	1		
13	Terminal Block	GX484503-0890	1		For Power
14	Screw	949006-3250	9		M4×0.7, L=10
15	Washer, Plate	90200-04331	11		
16	Screw	949006-3280	8		M4×0.7, L=18
17	Screw	480919-0740	2		M4×0.7, L=25
18	Grommet	LA484926-0600	3		
19	Grommet	484926-0290	1		
20	Holder, Fuse	GX484927-1141	1		
21	Fuse	GX481936-0131	1		25A
23	Terminal Block	GX484503-0840	1		For Input/Output Signal
24	Screw w/Washer	91310-03161	2		M3×0.5, L=16
26	Grommet	LA484926-0500	2		
27	Wire Assy	GX484930-9780	1		(TB)↔(Relay, Compressor)
28	Wire Assy	GX484930-9771	1		(TB)↔(Relay, Reverse Phase)
29	Wire Assy	GX484930-9790	1		
30	Wire Assy	GX484930-9760	1		(TB)↔(RB)
31	Wire Assy	LA484930-6311	1		
32	Screw	91051-04100	5		Ground (M4×0.7, L=10)
33	Washer, Plate	90201-04300	5		Ground
34	Wire Assy	GX484930-9070	1		Pump
35	Wire Assy	GX484930-9062	1		Main Harness (RB)↔(CB)

DENSO

DENSO SALES CALIFORNIA, INC.

Long Beach, CA 90810

www.movincool.com

Second Issue: June 2015