



**Product Model Numbers**  
**Ironing Centers: E-46 and NE-46**

**Dimensions (Actual Size)**

- Overall height: 60 5/8"
- Overall width: 15"
- Overall depth including door: 7 3/4"
- Dimension from wall to outer edge of door (when recessed): 3 7/8"
- Penetration into opening: 3 7/8"
- Rough opening height: 59 7/8"
- Rough opening width: 14 3/8"
- Wall opening depth: 3 7/8"

**Opening dimensions listed above**  
**Overlap distances when using wall**

- Top overlap: 3/8"                      Right side overlap: 3/8"
- Bottom overlap: 3/8"                Left side overlap: 3/8"

**Additional Information**

- Unit may be surface mounted (unit extends approximately 7 3/4" into room) or recessed (unit extends approximately 3 7/8" into room) into any wall with standard 16" center studs.
- See table bottom right to determine desired ironing board height above the floor.
- Unit can be provided with a left hinged door upon request. Right hinge is standard.
- Comes standard with wood veneer door.
- Electrical requirements for E-46: 115/120v, 15 amp. Pigtails are provided in bottom of wire raceway for hookup to supply line. Make entrance into knockout provided in top of wire way through left-hand vent hole. (Refer to Top View Diagram.)
- Electrical requirements for NE-46: Does not require electricity, non-electric.
- Recommended to attach 2" x 4" cleats to studs, level with the bottom of opening (for support when recessing unit.)
- Door opens approximately 180°. Allow at least 16" to the side of the unit for door to swing open (door hinges on full length piano hinge.)
- Options include: Surface mount trim (necessary for surface mounting), oak, maple, pine, or white raised panel door, flat white door, glass mirrored door, or no door, sleeve board, swivel, rough-in kit, and iron.

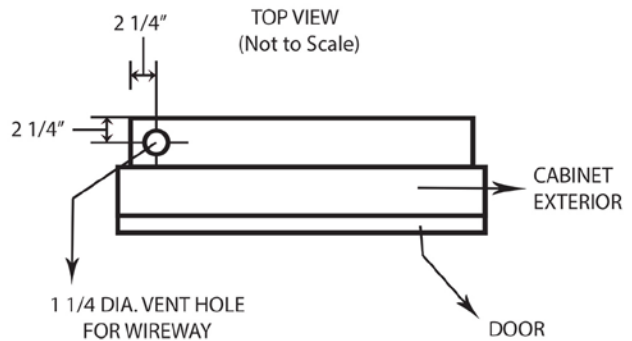
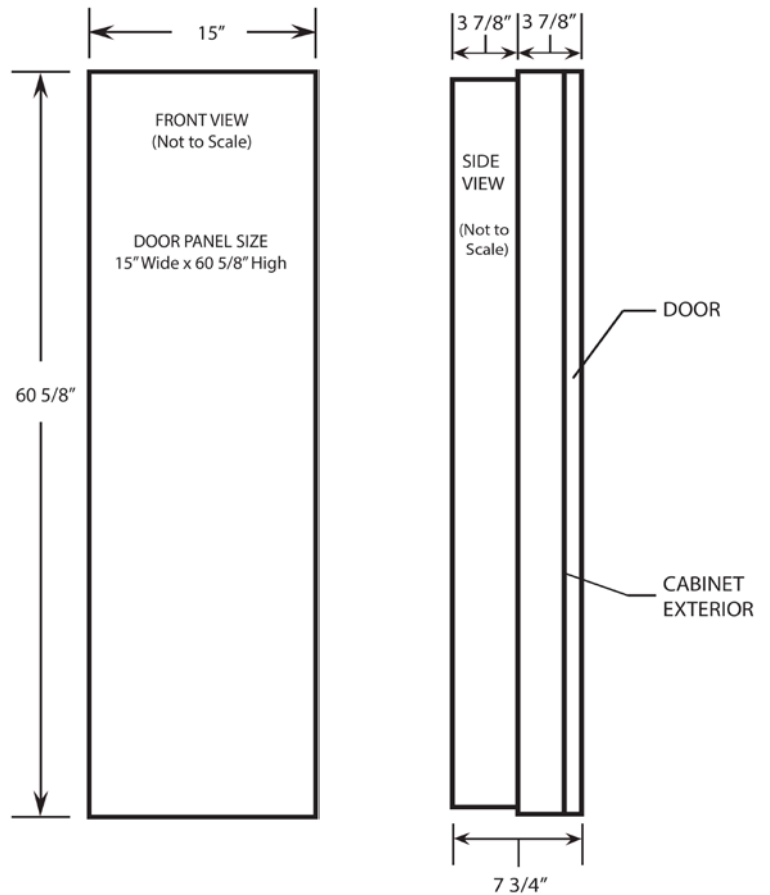

Ironing Board Height	
Cut Opening Above floor	Board Height
27"	38"
26"	37"
25"	36"
24"	35"
23"	34"
22"	33"
21"	32"
20"	31"
19"	30"

See Page 2 for additional information

Page 2  
Product Model E-46 and NE-46  
Additional Information

Measurements when board is lowered  
(Not to Scale)

Unit can be provided with a left hinged door upon request. Right hinge is standard.  
Door opens approximately 180°. Allow at least 16" from side of cabinet.

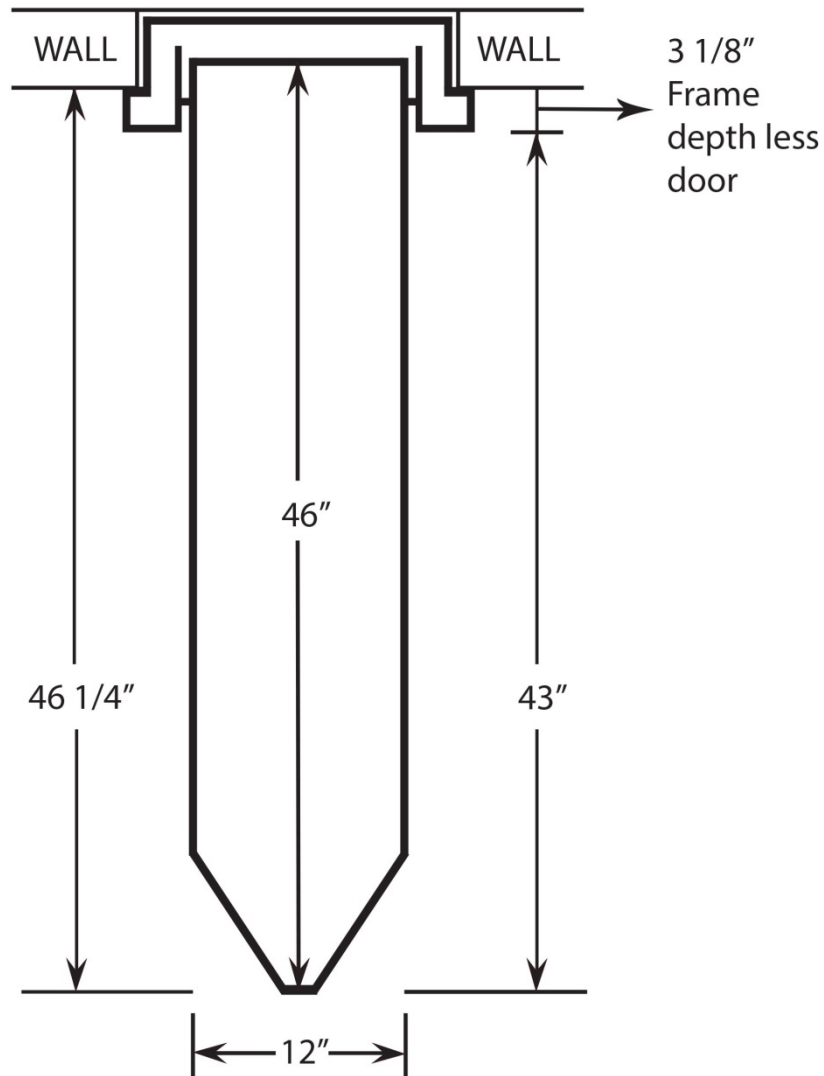

**Recommended Adequate Space/Clearance for Ironing**

Distance from Wall to tip of Ironing Board	46 1/4"
Swivel Clearance from cutout opening of cabinet	N/A
Distance from Wall in Full Swivel Position	N/A
Standing Area Clearance **	24"

\*\* The recommended distance from the side of the ironing board where the user will typically stand to ensure adequate space for ironing.