

GENERAL INFORMATION

Unpack

1. Remove banding from bottom of carton. Lift carton up and off of the ice machine
2. Remove all tape and packaging material from the outside and inside of the cabinet.
3. Keep all carton packaging until your ice machine has been thoroughly inspected and found to be in good condition.

Area Requirements

1. Place unit so the front side will be completely unobstructed to provide proper air flow. The unit may be closed in on the top and three sides, but the front **MUST BE** unobstructed for air circulation and proper operation. Installation should be such that the cabinet can be moved for servicing if necessary.
2. Unit should be in a well ventilated area. Best results are obtained at temperatures between 55°F (13°C) and 80°F (27°C) for built-in indoor models, between 55°F (13°C) and 90°F (32°C) for indoor freestanding models, and between 45°F (7.2°C) and 110°F (43°C) for outdoor models.
3. Provisions for electricity should be determined before placing unit in proper place.
4. For best performance, outdoor units should be installed away from direct sunlight or under a counter or sink.

UNDERCOUNTER CABINET CUTOUT

A	15" (38.1 cm)*
B	Min. 34 1/2" (87.6 cm) Max. 35 1/8" (89.2 cm)
C	24" (61.0 cm)

*15" (38.1 cm) width for cabinet only. If door is recessed between cabinets, cabinet cutout must be 15-1/4" (38.7 cm.).

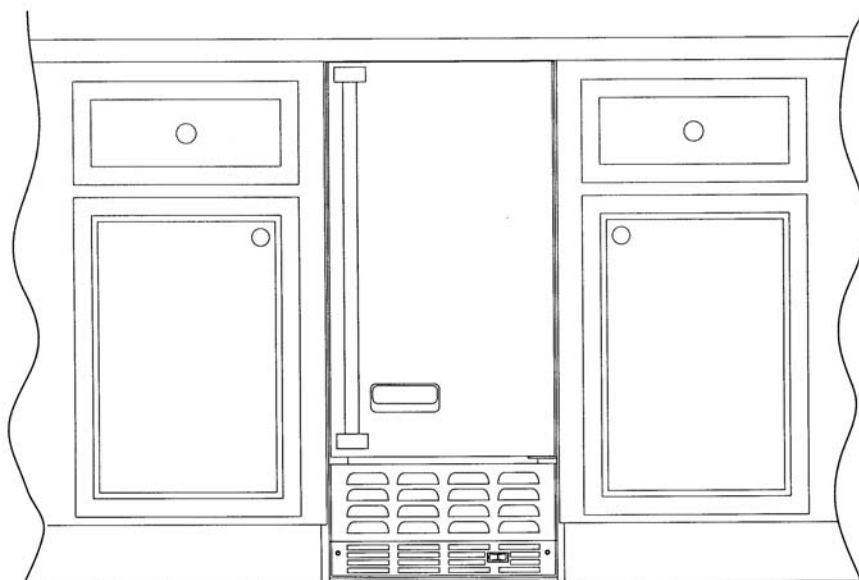
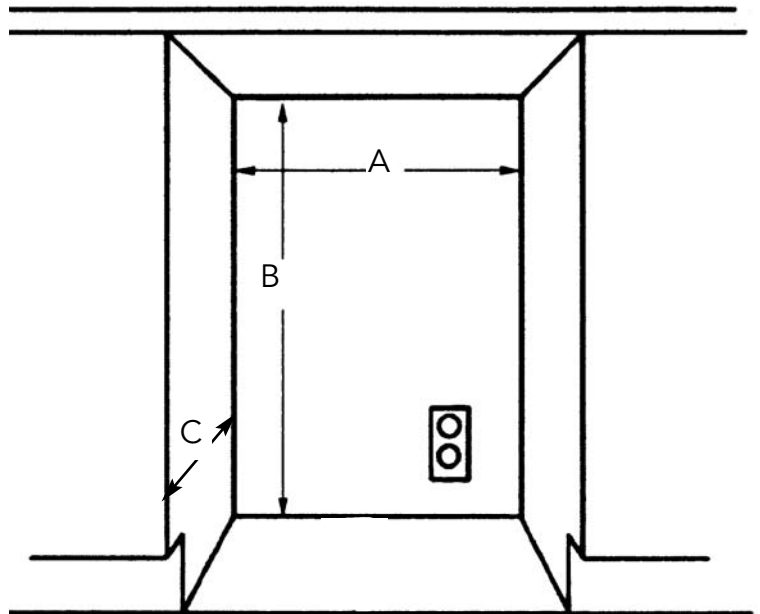

SPECIFICATIONS/DIMENSIONS PROFESSIONAL MODELS

Basic Electric Data

- 115 VAC/60 Hz
 - Maximum amps - 3.0
- Approximate Shipping Weight - 110 lbs.
(49.5 kg)

Front View

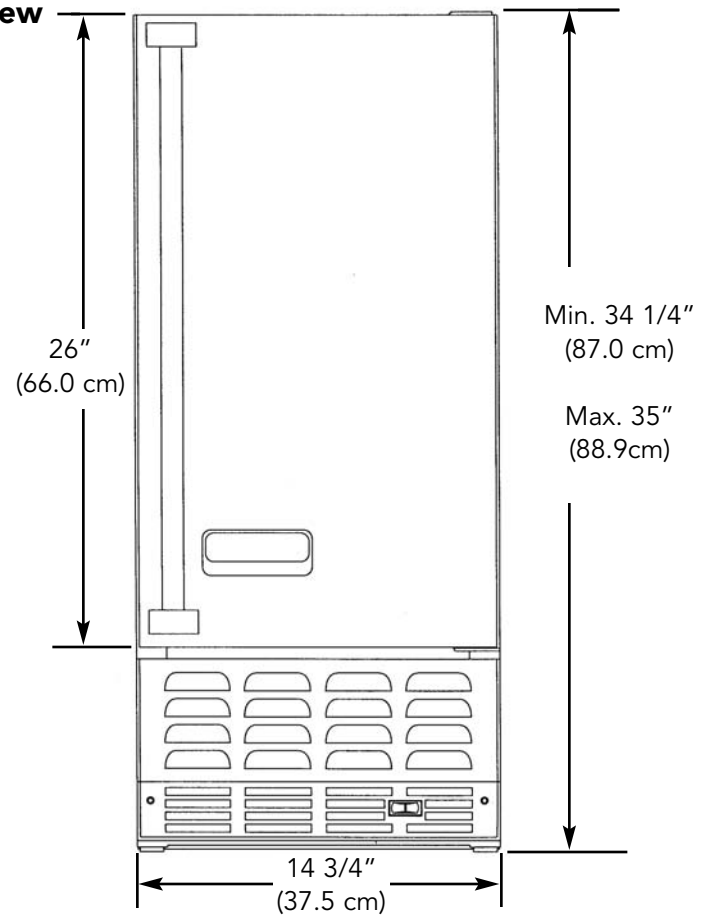

Side View

