

Viking Installation Guide

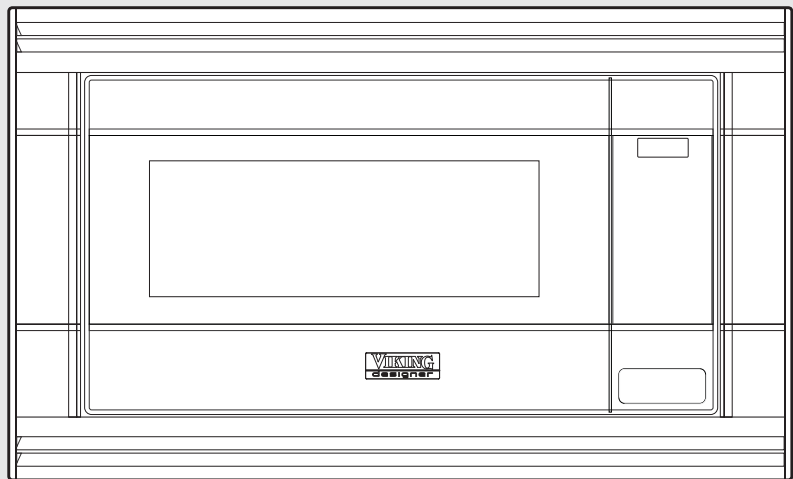

Designer Microwave Built-In Trim Kit

Table of Contents

Warnings & Important Information	2
Specifications	3
General Information	4
Parts Included in the Kit	4
Cabinet or Wall Cutout	4
Electrical Outlet Location	4
Installation	5
Mounting Template	5
Bottom Duct Assembly	6
Mounting Bracket Assembly	6
Cabinet Installation	7
Frame Assembly	7
Side Decoration Assembly (For Surface Mount Only)	8
Over Oven Installation	8
Performance Checklist	8

IMPORTANT—Please Read and Follow!

- Before beginning, please read these instructions completely and carefully.
- Be sure to DISCONNECT THE PLUG of the microwave oven from the electrical outlet before installing the built-in trim kit. Remove the turntable from the oven cavity.
- Because the kit includes metal parts, caution should be used in handling and installation to avoid the possibility of injury.
- Do not remove permanently affixed labels, warnings, or plates from the product. This may void the warranty.
- Please observe all local and national codes and ordinances.
- The installer should leave these instructions with the consumer who should retain for local inspector's use and for future reference.

WARNING

This built-in trim kit is designed for use **ONLY** with Viking microwave ovens specifying built-in trim kit DMTK302 on the rating label on the left side wall of the oven cavity.

Specifications

	Microwave Oven		Built-In Trim Kit	
	DMOS201		DMTK302	
Overall Width	24"	(60.9 cm)	29-1/2"	(74.9 cm)
Overall Height from Bottom	13-3/8"	(33.9 cm)	17-1/2"	(43.7 cm)
Overall Depth from Rear	19-1/8"	(48.7 cm)	NA	
Oven Interior	Width	17-3/8" (44.1 cm)	NA	
	Height	10-1/2" (26.6 cm)		
	Depth	18-5/8" (47.3 cm)		
	Overall	2.0 cu. ft.		
Electrical Requirements	120VAC/60 Hz		NA	
Max. Amp Usage	1.5 KW	13 amps	NA	
Approx. Shipping Wt.	46 lbs.	(20.9 kg)	15 lbs.	(6.9 kg)

* The International Electrotechnical Commission's standardized method for measuring output wattage. This test method is widely recognized.

In compliance with standards set by:

FCC – Federal Communications Commission Authorized.

DHHS – Complies with Department of Health and Human Services (DHHS) rule, CFR, Title 21, Chapter I, Subchapter J.

 – This symbol on the Rating label means the product is listed by Underwriters Laboratories, Inc. for use in USA or Canada.

General Information

Parts Included in the Kit

Item	Part Name	QTY
①	Frame Assembly	1
②	Bottom Duct	1
③	Mounting Bracket	2
④	Screw A :1-3/16" length	2
⑤	Screw B: 1-3/4" length	4
⑥	Side Decoration (Surface Mount Only)	2
⑦	Surface Mounting Template	1
⑧	Flush Mounting Template	1

Cabinet or Wall Cutout

Cutout Dimensions		Flush Mount	Surface Mount
Height (A)	Minimum	17-5/16" (439.8mm)	16-9/16" (420.7mm)
	Maximum	N/A	16-13/16" (427mm)
Width (B)	Minimum	29-5/8" (752.5mm)	27-3/4" (704.9mm)
	Maximum	N/A	28" (711.2mm)
Depth (C)	Minimum	20" (503mm)	20" (503mm)

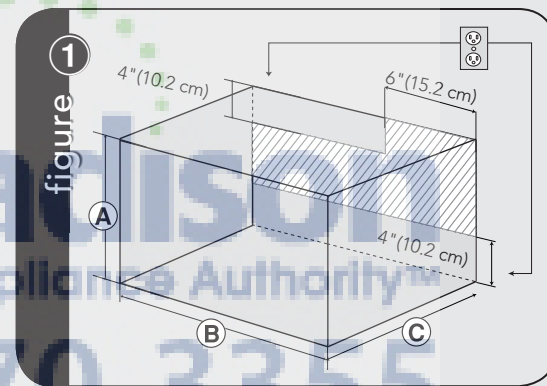
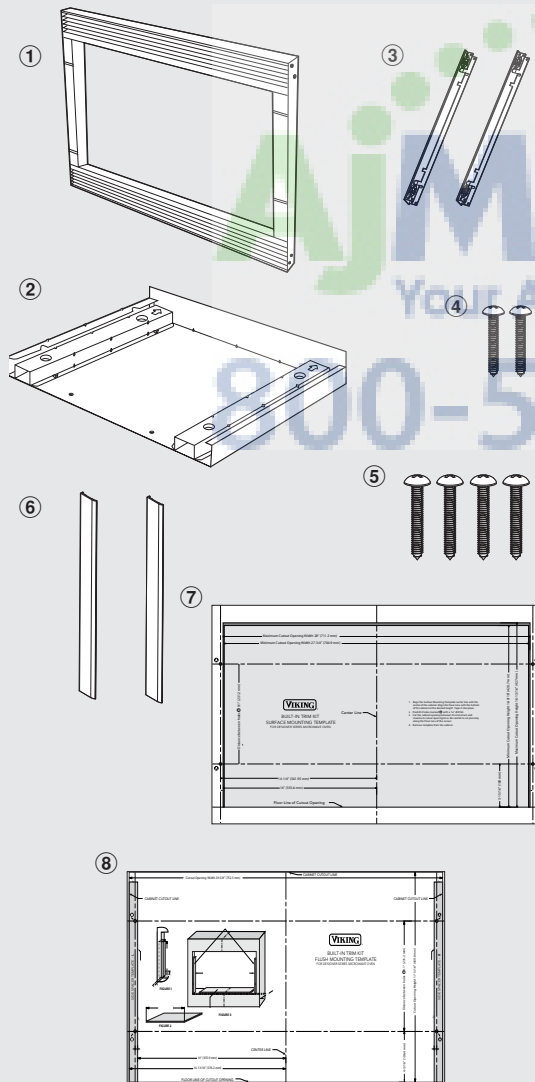

Electrical Outlet Location

⚠ CAUTION

Outlet should **NOT** be in the shaded area as indicated on figure 1.

NOTES:

- If the Depth (C) dimension is greater than 21" (53.3 cm), the outlet location may be in any area on the rear wall.
- The floor of the opening should be constructed of plywood strong enough to support the weight of the oven and floor load (approximately 100 pounds). The floor should be level for proper operation of the oven. Be sure to check the local building code as it may require that the opening be enclosed with side, ceiling and rear partition. The proper functioning of the oven does not require the enclosure.

Installation

Mounting Template

Determine which mounting method to use based on the required configuration. See figure 2A for FLUSH MOUNT and 2B for SURFACE MOUNT.

Align the template corresponding to the required mounting method to the center of the cabinet. Make sure that the template is level with the floor. Tape it into place. Cut the cabinet opening along the lines specified on the template. Leave template taped in place.

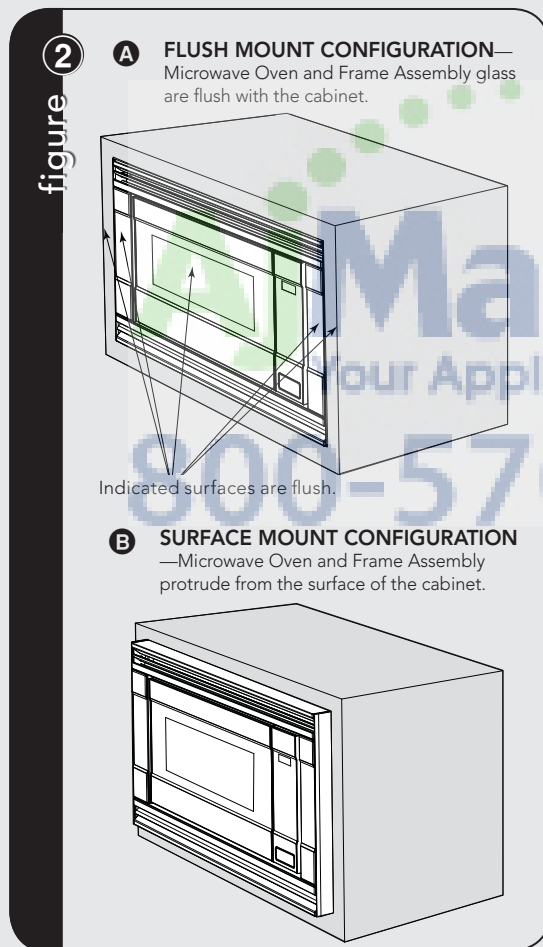

For SURFACE MOUNT, predrill 4 holes marked "A" with a 1/16" drill bit. Remove template from the cabinet. Go to Bottom Duct Assembly.

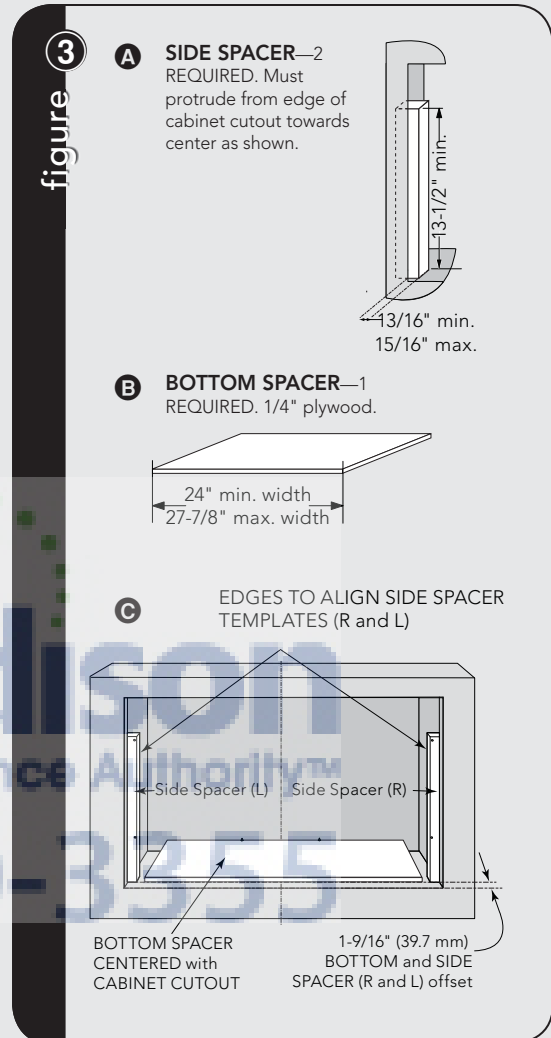

For FLUSH MOUNT, two (2) side spacers and one (1) bottom spacer are required. Spacers are not included in the kit and must be fabricated by installer. See figures 3A and 3B for spacer requirements. Make sure that all three spacers are offset from the front of the cabinet by 1-9/16".

Cut out the Side Spacer Templates (R and L) from the Flush Mounting Template. Align the indicated edges to the corresponding right and left side spacers as shown in figure 3. Make sure to align the bottom edges of the side spacer templates to the floor of the cabinet opening. Predrill two (2) holes marked "A" on Side Spacer Template – R and two (2) holes marked "B" on Side Spacer Template – L with 1/16" drill bit.

Remove templates from the cabinet.

Installation

Bottom Duct Assembly

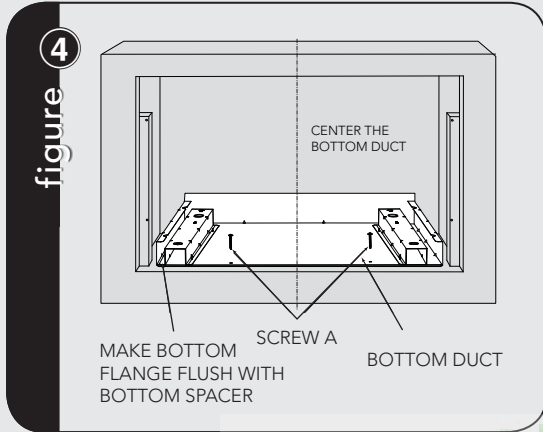

Place the Bottom Duct in the cabinet opening. For FLUSH MOUNT, it will rest on the bottom spacer centered with the cabinet. See figure 4.

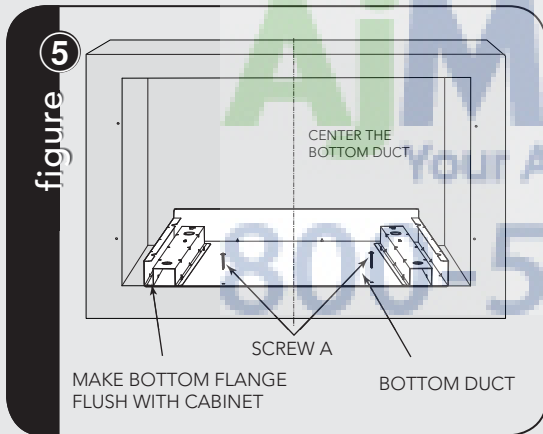

For SURFACE MOUNT, the Bottom Duct will rest on the floor of the opening. See figure 5.

Align the Bottom Duct to the center of the opening with the bottom flange securely flush with the bottom spacer (for FLUSH MOUNT) or the cabinet (for SURFACE MOUNT).

Secure the Bottom Duct Assembly with the two (2) SCREWS A. See figures 4 and 5 respectively.

Mounting Bracket Assembly

Position the mounting brackets to align with the predrilled holes that were drilled with the mounting template.

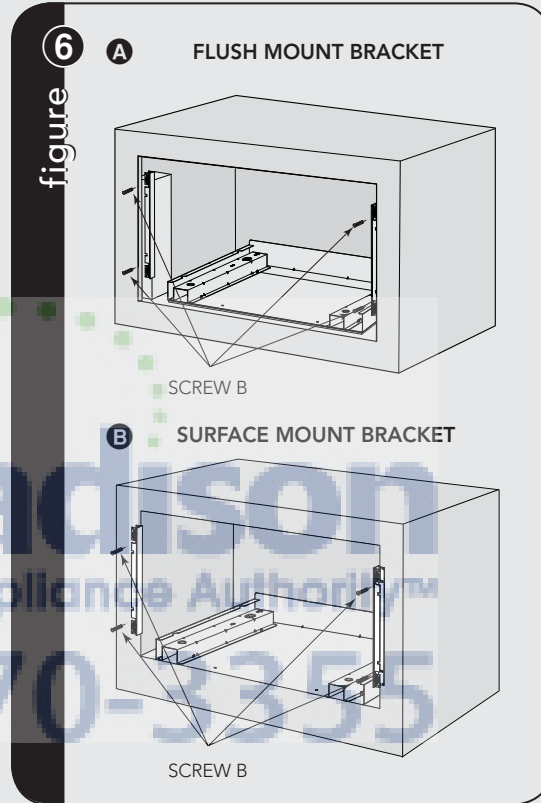

The enclosed ends of the mounting brackets should face inwards. Check that they are vertical and then secure loosely with four (4) Screws B. See Figure 6.

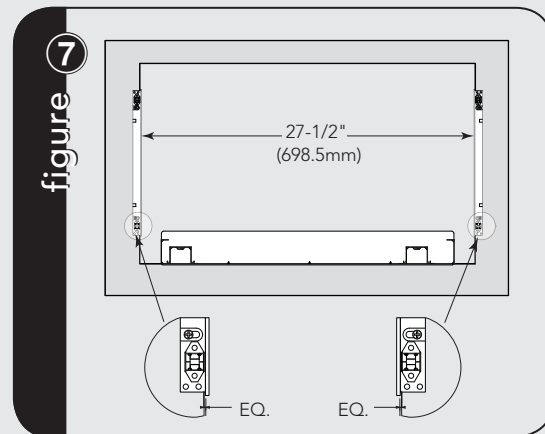

Installation

Align the mounting brackets horizontally by sliding them back and forth along the screw slots until the brackets are exactly 27-1/2" apart and equal distance from the cabinet sides. See figure 7.

Once the brackets are correctly positioned, securely tighten the four (4) screws B.

Cabinet Installation

Place the oven adjacent to the wall or cabinet opening. Plug the power cord into the electrical outlet.

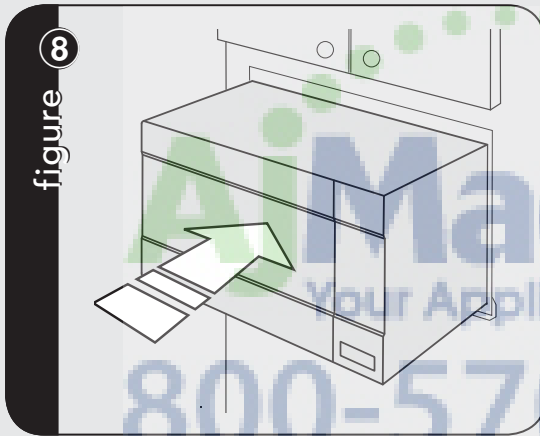

Carefully guide the assembled oven into the prepared opening. Slide the oven onto the Bottom Duct Assembly. See figure 8.

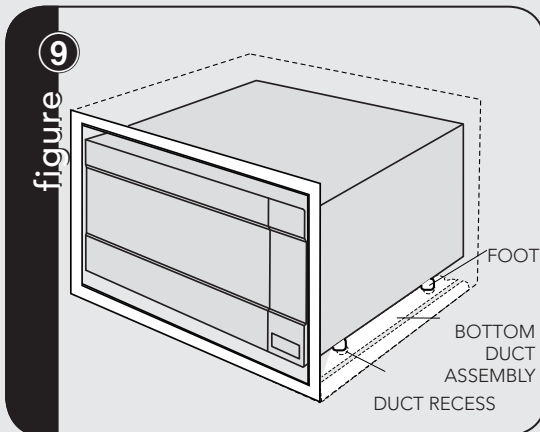

Avoid pinching the cord between the oven and the wall. Adjust the position of the oven so that the feet of the oven are fitted into the recesses of the Bottom Duct Assembly. See figure 9.

Frame Assembly

Turn over FRAME ASSEMBLY to locate the 4 ball studs.

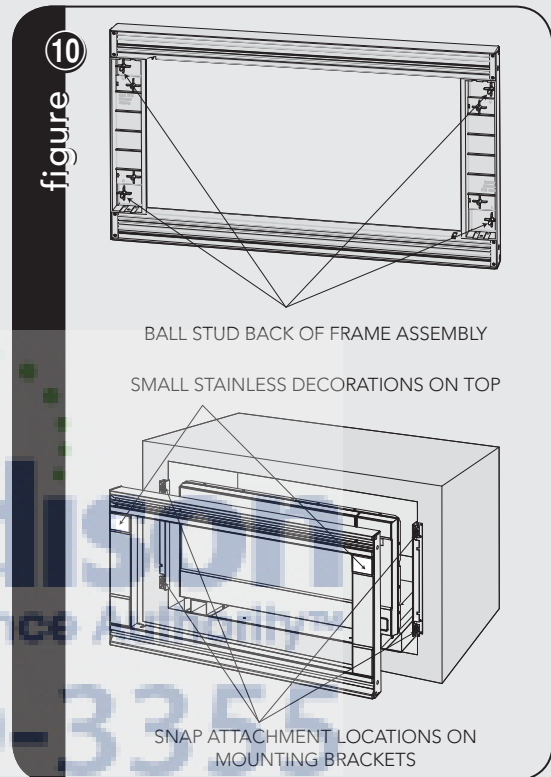

Position the FRAME ASSEMBLY with the small stainless decorations on top. Align the 4 ball studs with the 4 snap attachments at both ends of the MOUNTING BRACKETS.

Secure the FRAME ASSEMBLY by firmly pushing it onto the Mounting Brackets engaging the four (4) snap attachments. See Figure 10.

Installation

Side Decoration Assembly (For Surface Mount Only)

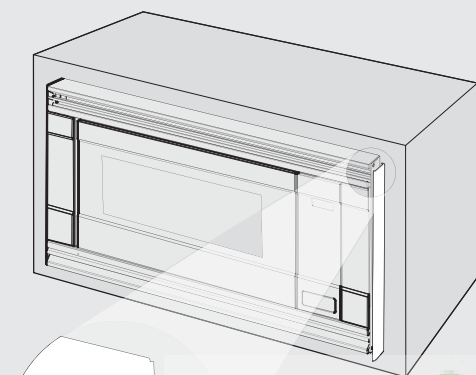

ALIGN TOP SURFACE OF SIDE DECORATION TO TOP SURFACE OF FRAME ASSEMBLY

FRONT INNER EDGE OF SIDE DECORATION

FRONT SIDE EDGE OF FRAME ASSEMBLY

Over Oven Installation

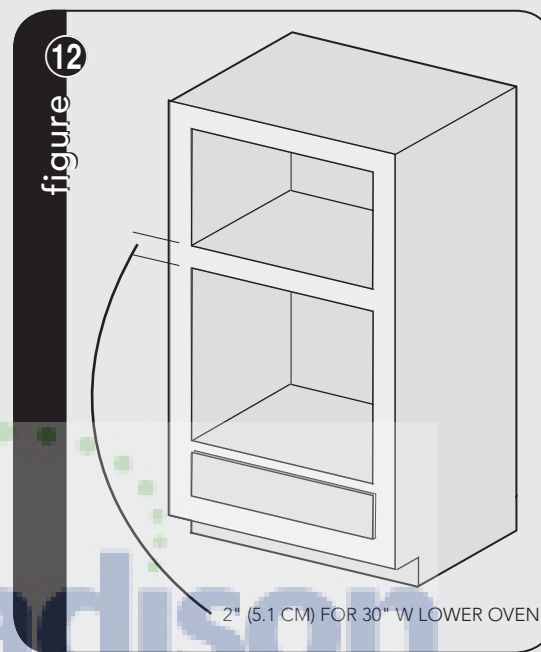

figure 12

2" (5.1 CM) FOR 30" W LOWER OVEN

Performance Checklist

1. Make sure the unit has been installed according to all of the Installation Instructions and the required Mounting Template.
2. Plug in the power cord.
3. Keep the Use & Care Manual and Installation Manual.

Viking Range Corporation
111 Front Street
Greenwood, Mississippi 38930 USA
(662) 455-1200

For product information
call 1-888-VIKING1 (845-4641)
or visit the Viking Web site at
vikingrange.com

