

Viking Use & Care Manual

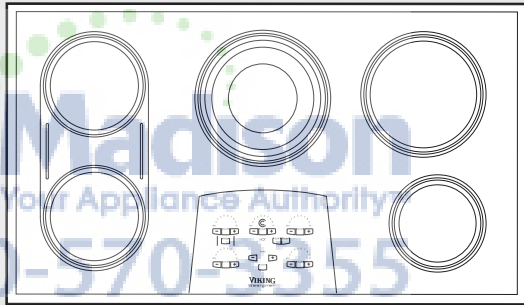
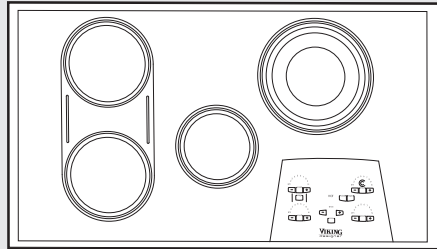

Designer Built-In
Electric Cooktops

Congratulations

Congratulations and welcome to the elite world of Viking ownership. We hope you will enjoy and appreciate the care and attention we have put into every detail of your new, state-of-the-art cooktop.

Your Viking cooktop is designed to offer years of reliable service. This Use and Care Manual will provide you with the information you need to become familiar with your product's care and operation.

Your complete satisfaction is our ultimate goal. If you have any questions or comments about this product, please contact the dealer from whom you purchased it, or contact our Consumer Support Center at 1-888-VIKING1 (845-4641).

We appreciate your choice of a Viking cooktop and hope that you will again select our products for your other major appliance needs.

For more information about the complete and growing selection of Viking products, contact your dealer or visit us online at www.vikingrange.com.



Aj Madison
Your Appliance Authority™
800-570-3355

Table of Contents

Getting Started

Warnings and Important Safety Information _____	4
Before Using Cooktop _____	9

Product Controls

Cooktop Features (30"W.) _____	10
Cooktop Features (36"W.) _____	11

Operation

Elements and Surface Heat Settings _____	12
Surface Operation _____	13
Cookware _____	17
Cooking Substitute Charts _____	18

Product Care

Cleaning and Maintenance _____	19
Troubleshooting _____	23
Service Information _____	24
Warranty _____	25



Warnings

Warning and Important Safety Instructions appearing in this manual are not meant to cover all possible conditions and situations that may occur. Common sense, caution, and care must be exercised when installing, maintaining, or operating this appliance.

ALWAYS contact the manufacturer about problems or conditions you do not understand.

Recognize Safety Symbols, Words, Labels

 DANGER
Hazards or unsafe practices which WILL result in severe personal injury or death
 WARNING
Hazards or unsafe practices which COULD result in death or severe personal injury
 CAUTION
Hazards or unsafe practices which COULD result in minor personal injury or property damage. All safety messages will identify the hazard, tell you how to reduce the chance of injury, and tell you what can happen if the instructions are not followed.

Read and follow all instructions before using this appliance to prevent the potential risk of fire, electric shock, personal injury or damage to the appliance as a result of improper usage of the appliance. Use appliance only for its intended purpose as described in this manual.

To ensure proper and safe operation: Appliance must be properly installed and grounded by a qualified technician. **DO NOT** attempt to adjust, repair, service, or replace any part of your appliance unless it is specifically recommended in this manual. All other servicing should be referred to a qualified servicer.

Warnings

WARNING



To avoid risk of property damage, personal injury or death; follow information in this manual exactly to prevent a fire or explosion, **DO NOT** store or use gasoline or other flammable vapors and liquids in the vicinity of this or any appliance.

To Prevent Fire or Smoke Damage

- Be sure all packing materials are removed from the appliance before operating it.
- Keep area around appliance clear and free from combustible materials, gasoline, and other flammable vapors and materials.
- If appliance is installed near a window, proper precautions should be taken to prevent curtains from blowing over burners.
- **NEVER** leave any items on the cooktop. The hot air from the vent may ignite flammable items and may increase pressure in closed containers which may cause them to burst.
- Many aerosol-type spray cans are **EXPLOSIVE** when exposed to heat and may be highly flammable. Avoid their use or storage near an appliance.
- Many plastics are vulnerable to heat. Keep plastics away from parts of the appliance that may become warm or hot. **DO NOT** leave plastic items on the cooktop as they may melt or soften if left too close to the vent or a surface element.
- Combustible items (paper, plastic, etc.) may ignite and metallic items may become hot and cause burns. **DO NOT** pour spirits over hot foods.

In Case of Fire

Turn off appliance and ventilating hood to avoid spreading the flame. Extinguish flame then turn on hood to remove smoke and odor.

- Smother fire or flame in a pan with a lid or cookie sheet. **DO NOT** use water on grease fires. Use baking soda, a dry chemical or foam-type extinguisher to smother fire or flame.
- **NEVER** pick up or move a flaming pan.

Warnings

Child Safety

- To eliminate the hazard of reaching over hot surface elements, cabinet storage should not be provided directly above a unit. If storage is provided, it should be limited to items which are used infrequently and which are safely stored in an area subjected to heat from an appliance. Temperatures may be unsafe for some items, such as volatile liquids, cleaners or aerosol sprays.
- **NEVER** leave children alone or unsupervised near the appliance when it is in use or is still hot.
- **NEVER** allow children to sit or stand on any part of the appliance as they could be injured or burned.
- **DO NOT** store items of interest to children over the unit. Children climbing to reach items could be seriously injured.
- Children must be taught that the appliance and utensils in it can be hot. Let hot utensils cool in a safe place, out of reach of small children. Children should be taught that an appliance is not a toy. Children should not be allowed to play with controls or other parts of the appliance.

Cooking Safety

- **ALWAYS** place a pan on a surface element before turning it on. Be sure you know which knob controls which surface element. Make sure the correct element is turned on. When cooking is completed, turn element off before removing pan.
- **NEVER** leave a surface cooking operation unattended especially when using a high heat setting or when deep fat frying. Boilovers cause smoking and greasy spillovers may ignite. Clean up greasy spills as soon as possible. **DO NOT** use high heat for extended cooking operations.
- **NEVER** heat an unopened container on the surface element. Pressure build-up may cause container to burst resulting in serious personal injury or damage to the appliance.
- Use dry, sturdy pot-holders. Damp pot-holders may cause burns from steam. Dish towels or other substitutes should **NEVER** be used as potholders because they can trail across hot surface elements and ignite or get caught on appliance parts.
- **ALWAYS** let quantities of hot fat used for deep fat frying cool before attempting to move or handle.
- **DO NOT** let cooking grease or other flammable materials accumulate in or near the appliance, hood or vent fan. Clean hood frequently to prevent grease from accumulating on hood or filter. When flaming foods under the hood, **TURN THE FAN OFF**.
- **NEVER** wear garments made of flammable material or loose fitting or long-sleeved apparel while cooking. Clothing may ignite or catch utensil handles.

Warnings

Cooking Safety (cont.)

- **PREPARED FOOD WARNING:** Follow food manufacturer's instructions. If a plastic frozen food container and/or its cover distorts, warps, or is otherwise damaged during cooking, immediately discard the food and its container. The food could be contaminated.
- If you are "flaming" liquor or other spirits under an exhaust, **TURN THE FAN OFF**. The draft could cause the flames to spread out of control.

Cookware Safety

- Use pans with flat bottoms and handles that are easily grasped and stay cool. Avoid using unstable, warped, easily tipped or loose-handled pans. Also avoid using pans, especially small pans, with heavy handles as they could be unstable and easily tip. Pans that are heavy to move when filled with food may also be hazardous.
- Be sure cookware is large enough to properly contain food and avoid boilovers. Pan size is particularly important in deep fat frying. Be sure pan will accommodate the volume of food that is to be added as well as the bubble action of fat.
- To minimize burns, ignition of flammable materials and spillage due to unintentional contact with the utensil, **DO NOT** extend handles over adjacent burners. **ALWAYS** turn pan handles toward the side or back of the appliance, not out into the room where they are easily hit or reached by small children.
- **NEVER** let a pan boil dry as this could damage the utensil and the appliance.
- Only certain types of glass, glass/ceramic, ceramic or glazed cookware are suitable for the cooktop surface without breaking due to the sudden change in temperature. Follow manufacturer's instructions when using glass.
- This appliance has been tested for safe performance using conventional cookware. **DO NOT** use any devices or accessories that are not specifically recommended in this guide. **DO NOT** use eyelid covers for the surface units. The use of devices or accessories that are not expressly recommended in this manual can create serious safety hazards, result in performance problems, and reduce the life of the components of the appliance.

Warnings

⚠ CAUTION

To avoid risk of property damage, **DO NOT** use cast iron cookware. Cast iron retains heat and may result in damaging the cooktop.

Heating Elements and Glass Ceramic Cooking Surfaces

- Surface areas on or adjacent to the unit may be hot enough to cause burns.
- **NEVER** touch the glass surface areas directly on or adjacent to the heating elements when the cooktop is in use.
- Heating elements may be hot even though they are dark in color. Areas near elements may become hot enough to cause burns.
- During and after use, **DO NOT** touch or let clothing or other flammable material contact surface of cooktop or areas near heating elements until they have had sufficient time to cool.
- **DO NOT COOK ON BROKEN COOKING SURFACE** – If cooking surface should break, cleaning solutions and spillovers may penetrate the broken cooking surface and create a risk of electric shock. Contact a qualified technician immediately.

Cleaning Safety

- Turn off all controls and wait for appliance parts to cool before touching or cleaning them. **DO NOT** touch the surface elements or surrounding areas until they have had sufficient time to cool.
- Clean appliance with caution. Use care to avoid steam burns if a wet sponge or cloth is used to wipe spills on a hot surface. Some cleaners can produce noxious fumes if applied to a hot surface.

⚠ WARNING



BURN OR ELECTRICAL SHOCK HAZARD

To avoid risk of injury or death, make sure all controls are OFF and surface is COOL before cleaning. Failure to do so can result in burns or electrical shock.

KEEP THESE INSTRUCTIONS FOR FUTURE REFERENCE.

Before Using Cooktop

- All products are wiped clean with solvents at the factory to remove any visible signs of dirt, oil, and grease which may have remained from the manufacturing process.
- If present, remove all packing and literature from the cooktop surface.
- **Clean your glass top before the first time you use it. A thorough cleaning with a glass top cleaner is recommended.** It only takes a minute and puts a clean, shiny coating on the glass top before its initial use.
- There may be a slight odor during the first several uses: this is normal and will disappear soon.
- The cooking surface will hold the heat and remain hot over 20 minutes after the elements have been turned off.
- The glass ceramic cooking surface is a durable material resistant to impact but not unbreakable if a pan or other object is dropped on it.
- **DO NOT** use aluminum foil directly on the glass; it will melt and damage the glass surface.
- **NEVER** cook food directly on the glass.

Cookware

- Using cast iron cookware on the glass cooktop is **NOT RECOMMENDED**. Cast iron retains heat and could damage the cooktop.
- Optimum cooking result depends on the proper cookware being selected and used.
- **DO NOT** allow pans to boil dry. This can damage the pan, element and /or cooktop.
- **DO NOT** slide cookware across cooking surface it may scratch the glass.

CAUTION

To avoid risk of property damage, **DO NOT** use cast iron cookware. Cast iron retains heat and may result in damage to the cooktop.

Cooktop Features (30"W.)

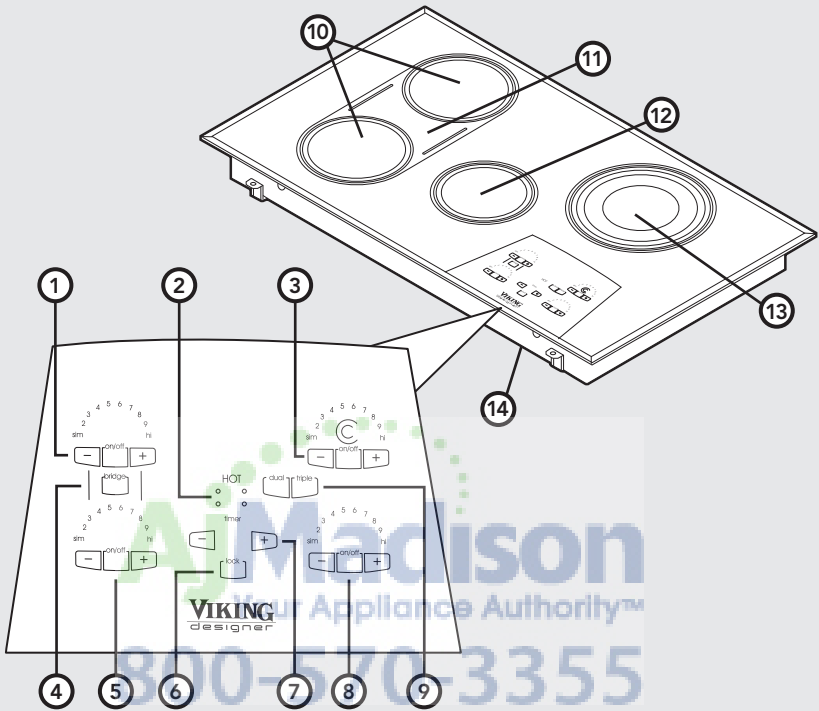

1. Controls for left rear element
2. Hot surface indicators
3. Controls for right rear element
4. Key to enable bridge element
5. Controls for left front element
6. Lock key and indicator
7. Timer
8. Controls for center element
9. Keys to enable extensions (dual, triple)
10. Two 7" 1,800-watt single elements
11. 800-watt bridge element
12. One 6" 1500-watt single element
13. One 9"/7"/5" 2500/1600/800-watt triple element
14. Serial plate

Cooktop Features (36"W.)

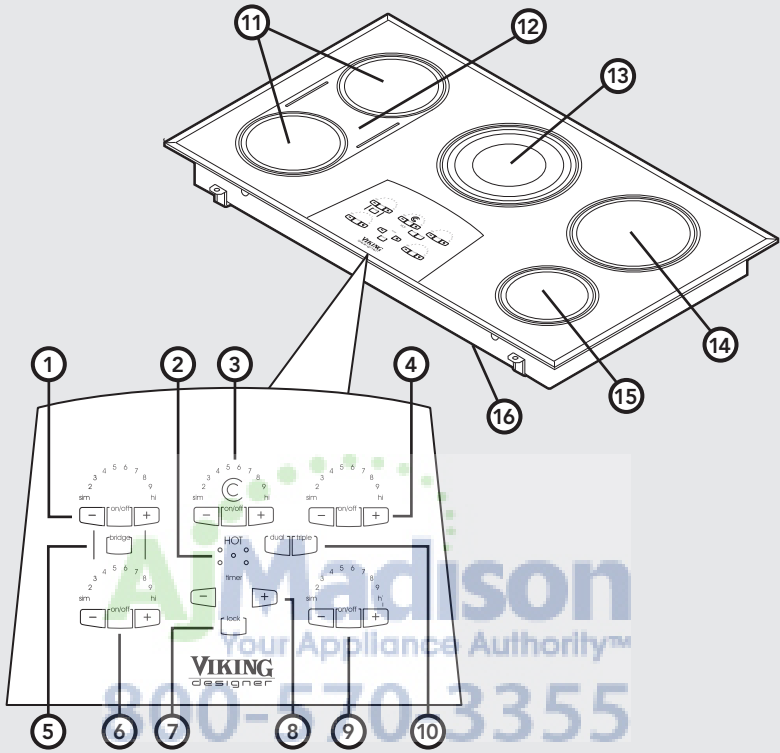

1. Controls for left rear element
2. Hot surface indicators
3. Controls for center element
4. Controls for right rear element
5. Key to enable bridge element
6. Controls for left front element
7. Lock key and indicator
8. Timer
9. Controls for right front element
10. Keys to enable extensions (dual, triple)
11. Two 7" 1,800-watt single elements
12. 800-watt bridge element
13. One 9 7/8" 2500/1600/800-watt triple element
14. One 8" 2100-watt single element
15. One 6" 1500-watt single element
16. Serial plate

Elements and Surface Heat Settings

Radiant Elements

This kind of electric heating elements use a ribbon wire located under the glass surface to provide the heat for cooking. The heating elements will cycle on and off, depending on the power level set and displayed by the control.

Temperature Limiters

Each radiant heater has its own temperature limiter to protect the glass cooking surface from extremely high temperatures. The limiter will operate automatically by cycling the element on and off.

Multiple Radiant Elements

Multiple heating elements (dual or triple) consist of two or three radiant ribbon elements within the same heating area. Either the small (main inner element) or the outer ones may be selected for use. The inner elements always work when an outer one is selected.

Bridge Radiant Element

A special multiple heating element consists of two independent radiant ribbon elements which can be connected enabling a bridge element in order to have a large heating area. When the bridge is enabled, the whole area works as a single unit. It is not possible to set different power levels for each of the three elements when the bridge is enabled.

Surface Heat Settings

Power Level Setting	Type of Food
Simmer	Melting butter, chocolate
3	Delicate sauce, rice, simmering sauces with butter and egg yolk
5	Cooking vegetables, fish broths, fried or scrambled eggs, pasta, milk, pancakes, pudding, simmering meats, steaming vegetables, bacon, stewing meat soup, sautéed vegetables, and spaghetti sauces
7	Braising meat, pan frying meat, fish, eggs, stir frying, quickly brown or sear meats, hold a rapid boil
High	Boiling water for vegetables, pasta

Note: The above information is given as a guide only. You may need to vary the heat settings to suit your personal requirements.

Surface Operation

Touch Control Detail

- “-” key decreases power level.
- “+” key increases power level.
- “ON/OFF” key selects or cancels the zone.
- The LED (Light Emitting Diode) power indicator arc indicates power levels from “sim” to “hi”. In the center are LED indicators for dual and triple zones (if applicable).

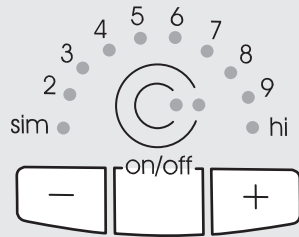

Hot Surface Indicator Lights

Each element has a HOT SURFACE indicator light to show when the cooking area is hot. This indication turns on when the zone is activated and remains ON until the cooking area has cooled down to a “safe to touch” temperature (approximately 150°F). If a hot surface light is ON use caution when working around the cooktop as it is still hot.



Power Supply

When the cooktop is connected to the power supply all lights and digits turn on to indicate a proper activation. This operation is completed after a few seconds and the control turns off automatically. Now the cooktop is ready for operation.

Key Lock Function

The key lock function is activated or deactivated by holding the “LOCK” key for 2 seconds. When the lock indication turns on, the keyboard is locked. The keys are automatically locked at start-up. The locking function can be activated regardless of the heaters condition (working or not). The lock function locks all the keys but the “ON/OFF” ones. The control locks itself automatically if it is not in use for 1 minute.

Activating Elements

Hold the “LOCK” key in case the commands are locked (see that the lock LED is on and turns off after a few seconds). Touch and hold the proper “ON/OFF” key for two seconds in order to select the desired zone. The “hi” LED indication starts flashing, waiting for user input.

The power level must be set within 10 seconds, otherwise the element remains off. Touch the “-” or “+” keys to change and eventually set the power level. The preset value is level 6.

Surface Operation

Simmering

A very delicate warming level corresponds to "Sim" position which uses about 2% of the available power. This position is recommended for delicate sauce and melting operations (butter, chocolate, etc.).

Switching Elements Off

Touch the related "OFF" key in order to stop an active heating element.

Activating Dual Elements

Select a dual heating area by touching and holding the related "ON" key for two seconds. The "hi" led indication starts flashing, waiting for user input. Touch the "DUAL" key in order to enable the outer ring of a dual zone. Touch "-" / "+" keys to change and eventually set the power level.

The dual element power indicator is on when the element is activated, and turns off when the element is disabled by pressing the "DUAL" key again.



Activating Triple Elements

To activate a triple element burner, touch and hold the proper "ON/OFF" key for two seconds in order to select the desired zones. At this time press the "DUAL" key followed by the "TRIPLE" key. You may now select the desired power levels for all three burners in conjunction. If you wish to deactivate the triple function, press the "TRIPLE" key once more. To deactivate the dual burner function as well, press the "DUAL" key again.



Surface Operation

Activating Bridge Element

Touch the "BRIDGE" key in order to enable the bridge element and set the entire cooking area (within and between both zones) as a single unit. The bridge indication light turns on and both the "hi" LED indications for the bridge elements start flashing, waiting for user input. Touch the "-" / "+" keys to change and eventually set the power levels for both elements simultaneously. The preset value is level 6. The HOT SURFACE indicator turns on as soon as the heating elements turn on.

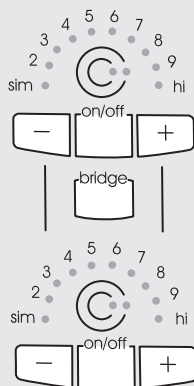

Once the bridge configuration is active, the "ON/OFF", "-", and "+" keys of the two single zones involved can be used indifferently to control the bridge area. The bridge configuration cannot be disabled by pressing the "BRIDGE" key. It's always necessary to switch one of the two main burners off to deactivate.

Setting the Timer

The timer can be set independently from the heating element, even if the unit is not in use.

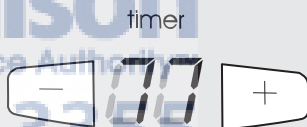

Touch the "-" or "+" keys to set the timer. The initial value starts from "30". Hold the key in order to quickly increase/decrease speed. The maximum value is "99".

To cancel the timer, hold the "-" key until the value decreases to "00" or touch both "-" and "+" simultaneously in order to reset the value to "00".

Residual Heat

The HOT SURFACE indicators remain on even after the end of the cooking activity and remain on until the surface cools down below a safe temperature.

The residual heat time depends on the power level that was set on the cooking zone and the time the heating element has been working for. For example, a cooking zone that has been working for more than 5 minutes at full power will take half an hour to cool down before the HOT SURFACE indication fades away. At level 1 it will take about 10 minutes.

Surface Operation

Continuous Use

The cooktop can work continuously for a maximum time of 10 hours. The control panel is checking its own ambient temperature and stops any activity in case of overheating of inner parts. Let the appliance cool down.

Error Codes

The control panel has an error detection system, mainly checking the functionality of the electronics (keyboard functionality, ambient light conditions, communication between the two boards and the working temperature of the control). As soon as an error is detected, the control panel stops all the heating elements and declares the error code, showing on the timer display "F" and a second letter in order to identify the error (see the table below).

Error Code	Error
FA, FC	Key error
FE, Ft	Temperature sensor failure
Fc	Over temperature
Fr	Relay error
FH	Control error (EEPROM)
FJ	Key error
FO	Software error
FL	Keyboard error (ambient light)
FU	Key error
Fd	LED On/Off test error
Fb	Keyboard error
F5	Communication error

Cookware

The choice of cookware directly affects the cooking performance (speed and uniformity). For best results select pans with the following features.

Flat Base

When a pan is hot, the base (pan bottom) should rest evenly on the surface without wobbling (rocking). Ideal cookware should have a flat bottom, straight side, a well fitting lid and the material should be of medium to heavy thickness. Rough finishes may scratch the cooktop.

Match Pan Diameter to Radiant Element

The base of the pan should cover or match the diameter of the element being used.

Recommended Cooking Utensils

- Copper: tin heats and cools quickly and can be used for gourmet cooking, lined wine sauces, and egg dishes.
- Stainless Steel: heats and cools and can be used for moderate soups, sauces, rate vegetables, and general cooking.

Cooking Utensils NOT RECOMMENDED

- Aluminium: heats and cools quickly and can be used for frying, braising, roasting. **May leave metal markings on glass.**
- Cast Iron: heats and cools quickly. **NOT RECOMMENDED. Retains excessive heat and may damage cooktop.**
- Enamel ware: response depends on base. **NOT RECOMMENDED, metal Imperfections in enamel may scratch cooktop.**
- Glass Ceramic: heats and cools slowly **NOT RECOMMENDED.** Heats too slowly. **Imperfections in enamel may scratch cooktop.**

Special pans

Special pans, such as griddles, roasters, pressure cookers, woks, water may be used. (Use only a flat-bottom wok).

CAUTION

Food packaged in aluminum foil should not be placed directly on the glass ceramic surface for cooking; aluminum foil can melt and cause permanent damage.

CAUTION

Plastic, paper, and cloth can melt or burn when in contact with a hot surface. **DO NOT** let these items come in contact with the hot glass.

Cooking Substitutes Charts

In many cases, a recipe requires an ingredient which is not readily available or calls for a unit of measure that is not easily recognized. The following charts have been provided as useful guides in these situations.

Ingredient Substitutes

Recipe calls for:	Substitute with:
1 tbsp. cornstarch	2 tbsp. flour (thickening)
1 whole egg	2 egg yolks plus 1 tbsp. water
1 c. whole milk	1 c. skim milk plus 2 tbsp. margarine or 1/2 c. evaporated milk plus 1/2 c. water
1 oz. unsweetened chocolate	3 tbsp. cocoa powder plus 1 tbsp. margarine
1 tbsp. baking powder	1/2 tsp. cream of tartar plus 1/4 tsp. baking soda
1/2 c. butter	7 tbsp. margarine or shortening
1 c. dairy sour cream	1 tbsp. lemon juice plus 1 c. evaporated milk

Canned Food Sizes

Can Size	Contents	Can Size	Contents
8 oz.	1 c.	No. 303	2 c.
Picnic	1-3/4 c.	No. 2	2-1/2 c.
No. 300	1-3/4 c.	No. 3	4 c.
No. 1 tall	2 c.	No. 10	12 c.

Kitchen Equivalent and Metrics

Measure	Equivalent	Metric*
1 tbsp.	3 tsp	15 mL
2 tbsp.	1 oz	30 mL
1 jig.	1-1/2 oz	45 mL
1/4 c.	4 tbsp.	60 mL
1/3 c.	5 tbsp. plus 1 tsp.	80 mL
1/2 c.	8 tbsp.	125 mL
1 c.	16 tbsp.	250 mL
1 pt.	2 c.	30 g
1 lb.	16 oz	454 g
2.21 lb.	35.3 oz	1 kg

Note: Rounded for easier measuring.

Cleaning and Maintenance

Any piece of equipment works better and lasts longer when maintained properly and kept clean. Cooking equipment is no exception. Your cooktop must be kept clean and maintained properly. Make sure all controls are in the "OFF" position.

Glass Ceramic Top

Cleaning of glass ceramic tops is different from cleaning a standard porcelain finish. To maintain and protect the surface of your new glass ceramic top, follow these basic steps:

For normal light soil:

1. Rub a few drops of a glass ceramic cream to the cool, soiled area using a damp paper towel.
2. Wipe until all soil and cream are removed. Frequent cleaning leaves a protective coating which is essential in preventing scratches and abrasions.

For heavy, burned soil:

1. Rub a few drops of glass ceramic cleaning cream to the cool, soiled area using a damp paper towel.
2. Carefully scrape remaining soil with a single-edged razor blade. Hold the blade at a 30° angle against the ceramic surface.
3. If any soil remains, repeat the steps above. For additional protection, after all soil has been removed, polish the entire surface with the cleaning cream.
4. Buff with a dry paper towel. As the cleaning cream cleans, it leaves a protective coating on the glass surface. This coating helps to prevent build-up of mineral deposits (water spots) and will make future cleaning easier.

Note: Dishwashing detergents remove this protective coating and therefore, make the glass ceramic top more susceptible to staining.

Cleaning and Maintenance

Cleaning Problems on Glass Ceramic Top

Problem	Cause	To Prevent	To Remove
Brown streaks and specks	Cleaning with sponge or cloth containing soil-laden detergent water.	Use cleaning cream with clean damp paper towel.	Use a light application of cleaning cream with a clean damp paper towel.
Blackened burned-on spots	Spatters or spillovers onto a hot cooking area or accidental melting of a plastic film, such as a bread.	Wipe all spillovers as soon as it is safe and DO NOT put plastic items on a warm cooking area.	Clean area with cleaning cream and a damp paper towel, non-abrasive nylon pad or scouring brush. If burn-on is not removed, cool cooktop, and carefully scrape area with a single edged razor blade held at a 30° angle.
Fine brown/gray lines or fine scratches or abrasions which have collected soil	Coarse particles (salt, sugar) can get caught on the bottom of cookware and become embedded into top. Using abrasive cleaning materials. Scratches from rough ceramic glass, or ceramic coated cookware.	Wipe the bottom of cookware before cooking. Clean top daily with cleaning cream. DO NOT use ceramic or ceramic coated cookware.	Fine scratches are not removable but can be minimized by daily use of cleaning cream.
Smearing or streaking	Use of too much cleaning cream or use of a soiled dishcloth.	Use a small amount of cream. Rinse thoroughly before drying. Use only paper towels or nylon scrub pad or brush.	Dampen paper towel with a mixture of vinegar and water and wipe surface. Wipe area with damp paper towel or lint free cloth.

Cleaning and Maintenance

Cleaning Problems on Glass Ceramic Top (cont.)

Problem	Cause	To Prevent	To Remove
Metal markings silver/gray marks	Sliding or scraping metal cookware on glasstop.	DO NOT slide metal objects across top.	Remove metal marks before the glasstop is used again. Apply cleaning cream with a damp paper towel and scrub with a nylon scrub pad or brush. Rinse thoroughly and dry.
Hard water spots	Condensation from cooking may cause minerals found in water and acids to drip on glasstop and cause gray deposits. (The spots are often so thin they appear to be in the glasstop.)	Make sure the bottom of cookware is dry before cooking. Daily use of cleaning cream will help keep top free from hard water mineral deposits and food discoloration.	Mix cleaning cream with water and apply a thick paste to stained area. Scrub vigorously. If stain is not removed, reapply cleaner and repeat process. Also try cleaning procedure for smearing and streaking.
Pitting or flaking	Boil over of sugar syrup on glasstop. This can cause pitting if not removed immediately.	Watch sugar and syrups carefully to avoid boil overs.	Turn element to LO; using several paper towels to wipe the spill immediately. Let glasstop cool and carefully scrape off remainder of burn-off with a single edged razor held at a 30° angle.

Cleaning and Maintenance

Cooktop Surfaces

Several different finishes have been used on your cooktop. Cleaning instructions for each surface are given below. **NEVER** USE AMMONIA, STEEL WOOL PADS OR ANY ABRASIVE CLOTHS AND MATERIALS SUCH AS CLEANSERS, OVEN CLEANERS OR ABRASIVE POWDERS. THEY CAN PERMANENTLY DAMAGE YOUR COOKTOP.

Control Panel

DO NOT use any cleaners containing ammonia or abrasives. They could remove the graphics from the control panel. Use hot, soapy water and a soft, clean cloth. **DO NOT** spray liquids directly onto the control panel.



Troubleshooting

Problem	Possible Cause and/or Remedy
Cooktop will not function.	<p>Cooktop is not connected to electrical power. Have electrician verify that the proper rated cooktop voltage is being supplied to the cooktop. Have electrician replace fuse or reset circuit breaker.</p> <p>Fuse is blown, circuit breaker is tripped, or no electricity to the cooktop. Have electrician check your power supply.</p> <p>Cooktop is in lockout mode. Unlock cooktop.</p>
Heating elements do not heat properly	<p>Cooktop is not connected to power supply. Have electrician connect cooktop to the proper rate cooktop voltage.</p> <p>Power supply connection is loose. Have electrician tighten the connections at the junction box.</p> <p>Improper cookware being used. Select proper cookware as outlined in the <i>Cooktop Operation</i> section of this manual.</p>
Heating elements cycle off even when elements are turned to their highest setting.	<p>Heating element temperature limiters are temporarily shutting off the elements due to exceeding the maximum allowable temperature.</p> <p>This is a normal operating condition, especially during rapid heat-up operations. The element will cycle back on automatically after it has cooled sufficiently.</p>
Glass ceramic surface is see-through or appears to be red in color.	<p>Under direct or bright lighting, you will sometimes be able to see through the glass and into the chassis due to its transparent quality. You may also notice a red tint under these conditions.</p> <p>These are normal properties of black ceramic glass panels.</p>

Service Information

If service is required, call your dealer or authorized service agency. The name of the authorized service agency can be obtained from the dealer or distributor in your area.

Have the following information readily available.

- Model number
- Serial number
- Date purchased
- Name of dealer from whom purchased

Clearly describe the problem that you are having. If you are unable to obtain the name of an authorized service agency, or if you continue to have service problems, contact Viking Range Corporation at 1-888-VIKING1 (845-4641), or write to:

**VIKING RANGE CORPORATION
PREFERRED SERVICE
1803 Hwy 82W
Greenwood, Mississippi 38930 USA**

Record the information indicated below. You will need it if service is ever required. The model and serial number for your cooktop can be found by looking under the control panel.

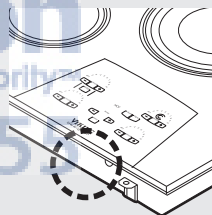

Model no. _____ Serial no. _____

Date of purchase _____ Date installed _____

Dealer's name _____

Address _____

If service requires installation of parts, use only authorized parts to insure protection under the warranty.

Keep this manual for future reference.

Warranty

DESIGNER ELECTRIC COOKTOP WARRANTY

ONE YEAR FULL WARRANTY

Electric cooktops and all of their component parts, except as detailed below*, are warranted to be free from defective materials or workmanship in normal household use for a period of twelve (12) months from the date of original retail purchase. Viking Range Corporation, warrantor, agrees to repair or replace, at its option, any part which fails or is found to be defective during the warranty period.

*Painted and decorative items are warranted to be free from defective materials or workmanship for a period of ninety (90) days from the date of original retail purchase. ANY DEFECTS MUST BE REPORTED TO THE SELLING DEALER WITHIN NINETY (90) DAYS FROM DATE OF ORIGINAL RETAIL PURCHASE.

Viking Range Corporation uses the most up-to-date processes and best materials available to produce all color finishes. However, slight color variation may be noticed because of the inherent differences in painted parts and porcelain parts as well as differences in kitchen lighting, product locations, and other factors.

FIVE YEAR LIMITED WARRANTY

Any electric element which fails due to defective materials or workmanship in normal household use during the second through fifth year from the date of original retail purchase will be repaired or replaced, free of charge for the part itself, with the owner paying all other costs, including labor.

NINETY (90) DAY RESIDENTIAL PLUS WARRANTY

This warranty applies to applications where use of the product extends beyond normal residential use. Examples are, but not limited to, bed and breakfasts, fire stations, private clubs, churches, etc. This warranty excludes all commercial locations such as restaurants, food service locations and institutional food service locations.

This warranty extends to the original purchaser of the product warranted here under and to each transferee owner of the product during the term of the warranty.

This warranty shall apply to products purchased and located in the United States and Canada. Products must be purchased in the country where service is requested. Warranty labor shall be performed by an authorized Viking Range Corporation service agency or representative. Warranty shall not apply to damage resulting from abuse, accident, natural disaster, loss of electrical power to the product for any reason, alteration, outdoor use, improper installation, improper operation, or repair or service of the product by anyone other than an authorized Viking Range Corporation service agency or representative. This warranty does not apply to commercial usage. Warrantor is not responsible for consequential or incidental damage whether arising out of breach of warranty, breach of contract, or otherwise. Some jurisdictions do not allow the exclusion or limitation of incidental or consequential damages, so the above limitation or exclusion may not apply to you.

Owner shall be responsible for proper installation, providing normal care and maintenance, providing proof of purchase upon request, and making the appliance reasonably accessible for service. If the product or one of its component parts contains a defect or malfunction during the warranty period, after a reasonable number of attempts by the warrantor to remedy the defects or malfunctions, the owner is entitled to either a refund or replacement of the product or its component part or parts. Warrantor's liability on any claim of any kind, with respect to the goods or services covered hereunder, shall in no case exceed the price of the goods or service or part thereof which gives rise to the claim.

WARRANTY SERVICE

Under the terms of this warranty, service must be performed by a factory authorized Viking Range Corporation service agent or representative. Service will be provided during normal business hours, and labor performed at overtime or premium rates shall not be covered by this warranty. To obtain warranty service, contact the dealer from whom the product was purchased, an authorized Viking Range Corporation service agent, or Viking Range Corporation. Provide model and serial number and date of original purchase. For the name of your nearest authorized Viking Range Corporation service agency, call the dealer from whom the product was purchased or Viking Range Corporation.

IMPORTANT: Retain proof of original purchase to establish warranty period.

The return of the Owner Registration Card is not a condition of warranty coverage. You should, however, return the Owner Registration Card so that Viking Range Corporation can contact you should any question of safety arise which could affect you.

Any implied warranties of merchantability and fitness applicable to the above described electric element are limited in duration to the period of coverage of the applicable express written limited warranties set forth above. Some jurisdictions DO NOT allow limitations on how long an implied warranty lasts, so the above limitation may not apply to you. This warranty gives you specific legal rights, and you may also have other rights which may vary from jurisdiction to jurisdiction.

Specifications subject to change without notice.

Notes



Notes





Viking Range Corporation
111 Front Street
Greenwood, Mississippi 38930 USA
(662) 455-1200

For product information,
call 1-888-VIKING1 (845-4641)
or visit the Viking Web site at
vikingrange.com