

# INSTALLATION INSTRUCTIONS

**BUILT-IN BOTTOM MOUNT REFRIGERATOR/FREEZER  
BRTGK72SS/PBRTGK72SS GRILLE KITS  
(FOR PROFESSIONAL SERIES ONLY)**

VIKING RANGE CORPORATION  
111 Front Street  
Greenwood, Mississippi 38930 USA  
(662) 455-1200

## IMPORTANT - PLEASE READ AND FOLLOW

Make sure that incoming voltage is the same as unit rating. An electric rating plate specifying voltage, frequency, wattage, amperage, and phase is attached to the product.

Please refer to Installation Instructions provided with bottom mount refrigerator/freezer for additional information.

To reduce the risk of fire, electric shock, or injury to persons, installation work and electrical wiring must be done by qualified people in accordance with all applicable codes and standards, including fire-rated construction.

**The installer should leave these instructions with the consumer who should retain for local inspector's use and for future reference.**

## GENERAL INFORMATION

Your safety and the safety of others is very important.

We have provided many important safety messages in this manual and on your appliance. Always read and obey all safety messages.

This is the safety alert symbol. This



symbol alerts you to hazards that can kill or hurt you and others.

All safety messages will be preceded by the safety alert symbol and the word "DANGER" or "WARNING".

These words mean:

### **! DANGER**

You will be killed or seriously injured if you don't follow instructions.

### **! WARNING**

You can be killed or seriously injured if you don't follow instructions.

All safety messages will identify the hazard, tell you how to reduce the chance of injury, and tell you what can happen if the instructions are not followed.

### **! WARNING**



#### TIP OVER HAZARD

Refrigerator is top heavy and tips easily when not completely installed.  
Keep doors closed until refrigerator is completely installed and secured with lag bolts to rear wall. Use two or more people to move and install refrigerator. Failure to do so can result in death or serious injury

Most of the refrigerator's weight is at the top. Extra care is needed when moving the refrigerator to prevent tipping.

Keep cardboard shipping piece or plywood under refrigerator until it is installed in the operating position.

It is your responsibility to :

- comply with installation specifications and dimensions
- properly install refrigerator
- remove any moldings or decorative panels that prevent the refrigerator from being serviced
- make sure that you have these materials, (not provided with the unit), which are necessary for proper installation:
  - 2 - 1/4" (6 mm) copper tubing with shutoff valve
  - 2 - 1/4" (6mm) compression fitting
  - #8 x 3" (7.6 cm) wood screws (Longer screws may be required.)
    - BRTGK72SS - Qty 12
    - PBRTGK72SS - Qty 12
  - 2 - saddle valves (do not use self-piercing valves).

-assure that floor will support refrigerator, door panels and contents, (approximately 1200 lbs. [540 kg.]

-provide a properly grounded electrical outlet

-assure that location will permit appliance doors to open 90° minimum

# BASIC SPECIFICATIONS AND DIMENSIONS

## VCBB363-DUAL INSTALLATION

DESCRIPTION	BRTGK72SS	PBRTGK72SS
Overall Width	72" (182.9 cm)	
Overall Height from Bottom	Min. 82 3/4" (210.2 cm) Max. 84 1/16" (213.5 cm)	
Overall Depth from Rear	To rear edge of side trim	22 3/16" (56.4 cm)
	To front of top grille	24 11/16" (62.7 cm)
	To end of handle bracket	27 1/4" (69.2 cm)
Cutout Width	71 1/2" (181.6 cm)	
Cutout Height	Min. 82 7/8" (210.3 cm) Max. 84 1/16" (213.5 cm)	
Cutout Depth	24" (61.0 cm) min.	
Electrical Requirements	(2) - 115 volt, 60 Hz, 15 amp dedicated circuit; 3-wire cord with grounded 3-prong plug attached to product.	
Maximum Amp Usage	9.9 amps (per unit)	
Inlet Water Requirements	(2) - 1/4" copper tubing inlet waterline; minimum 20 psi; maximum 120 psi	
Overall Interior Capacity	<b>(per unit)</b>	
•Refrigerator	15.2 cu. ft. (.43 cu. meters)	
•Freezer	5.1 cu. ft. (.14 cu. meters)	
•Total Capacity	20.3 cu. ft. (.57 cu. meters)	
Approximate Shipping Weight	575 lbs. (258.8 kg) - per unit	

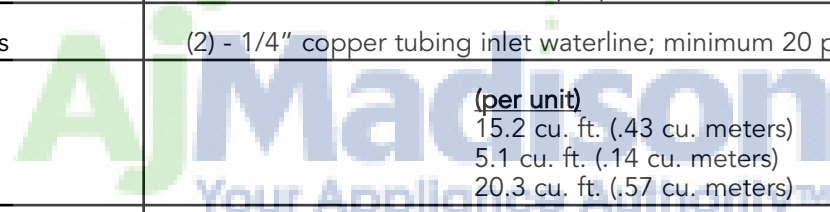
  
 Your Appliances Authority
   
 800-570-3355

# SITE PREPARATIONS AND CONSIDERATIONS

**BRTGK72SS**

## PROFESSIONAL 36" W. BOTTOM MOUNT DUAL INSTALLATION, CABINET OPENING DIMENSIONS

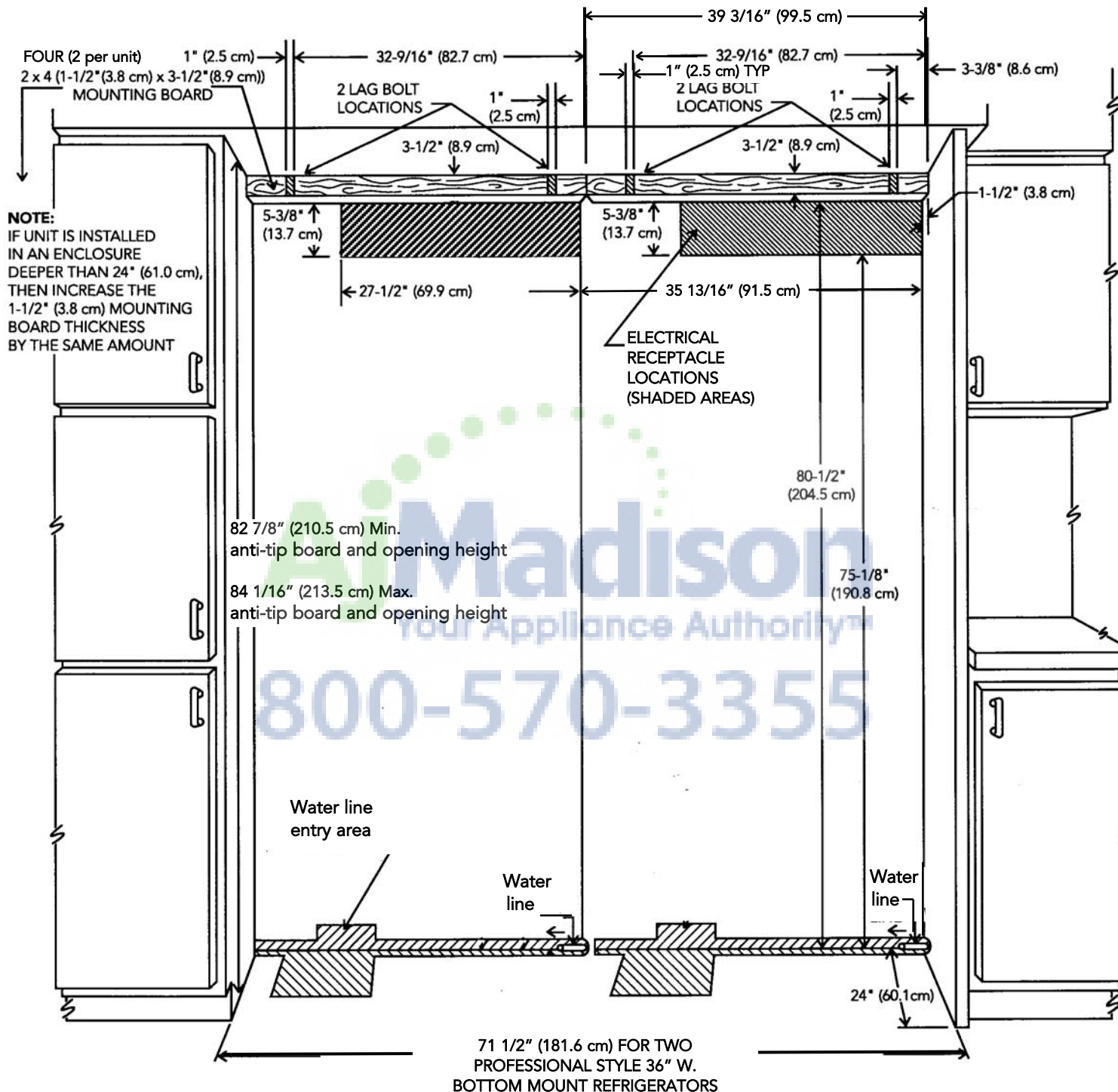

# SITE PREPARATIONS AND CONSIDERATIONS

PBRTGK72SS

## PROFESSIONAL 36" W. BOTTOM MOUNT DUAL INSTALLATION, CABINET OPENING DIMENSIONS

(2 per unit) 2" x 4" mounting boards (1-1/2" [3.8 cm] x 3-1/2" [8.9 cm])

NOTE: If unit is installed deeper than 24" (61.0 cm), then shim behind anti-tip bracket thickness by the same amount.

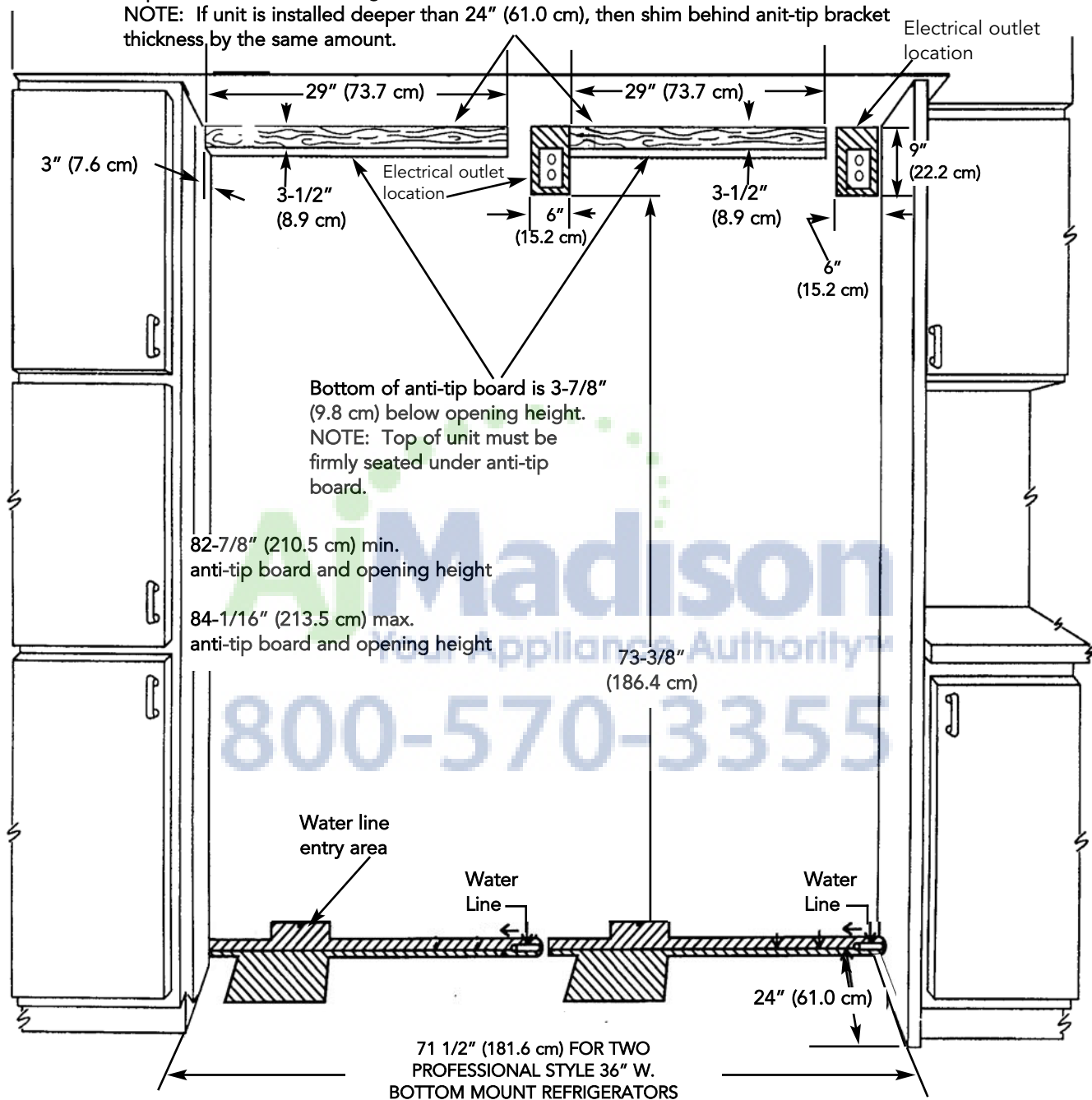

# GRILLE ASSEMBLY/INSTALLATION PROFESSIONAL MODEL BRTGK72SS (FOR PBRTGK72SS INSTALLATION - SKIP TO PAGE 9)

Before moving the refrigerators in place, confirm the finished dimensions, electrical, and plumbing locations, minimum door clearances, and door panel installations are accurate. (See Installation Instructions provided with refrigerators).

1. Position refrigerators in front of cutout.
2. Remove the top air grille assemblies from both of the refrigerators.
  - a. Remove the center grille blades by lifting up and pulling forward.
  - b. Remove the grille/end cap assembly by removing the four (4) screws in each black air duct.
  - c. Remove the black air ducts by removing the eight (8) screws on the right hinge model and the seven (7) screws on the left hinge model. Save the air ducts for the 72" grille installation.

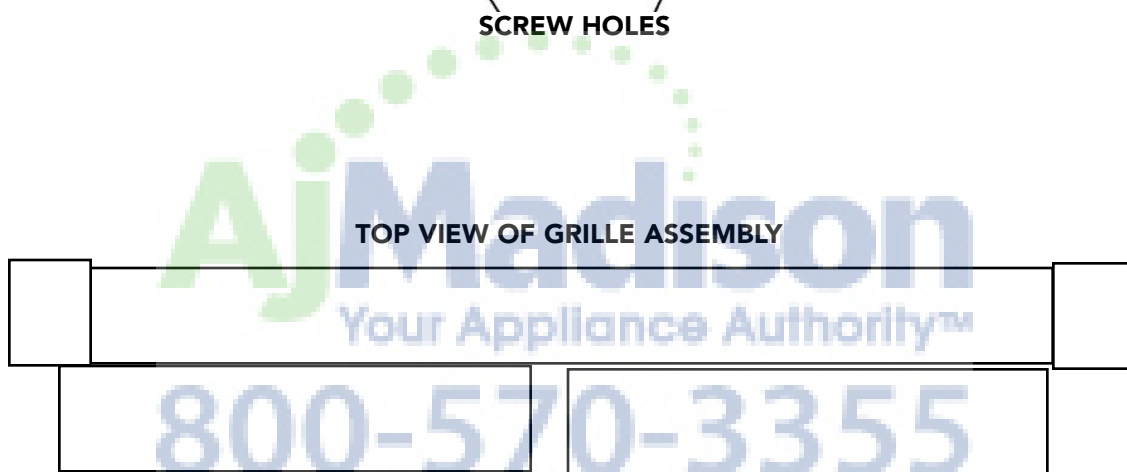
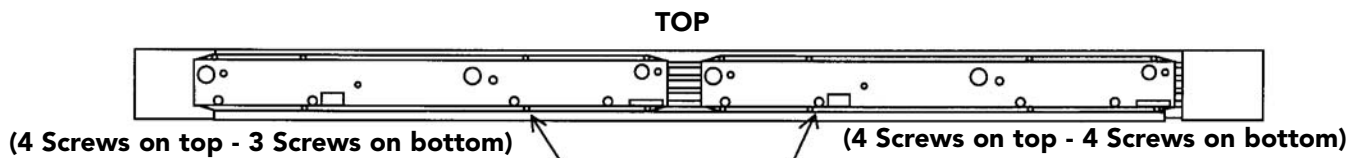

## EXPLODED SIDE VIEW OF GRILLE ASSEMBLY (15 Screws Used)

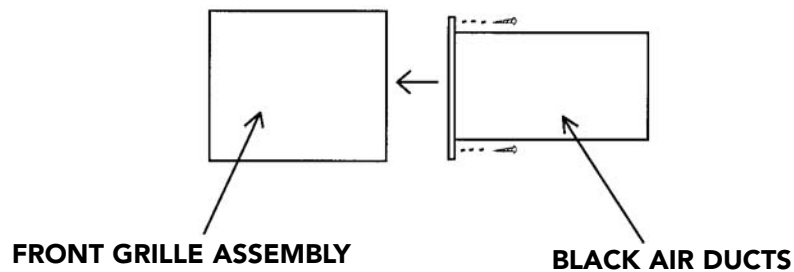

3. Verify operation by plugging in power cord. **Power switch will be shipped in the ON position and showroom switch will be in the ON position.** (If showroom switch is switched to the "OFF" position, showroom mode is engaged and power is shut off to the compressor. This mode is for showroom display only.)

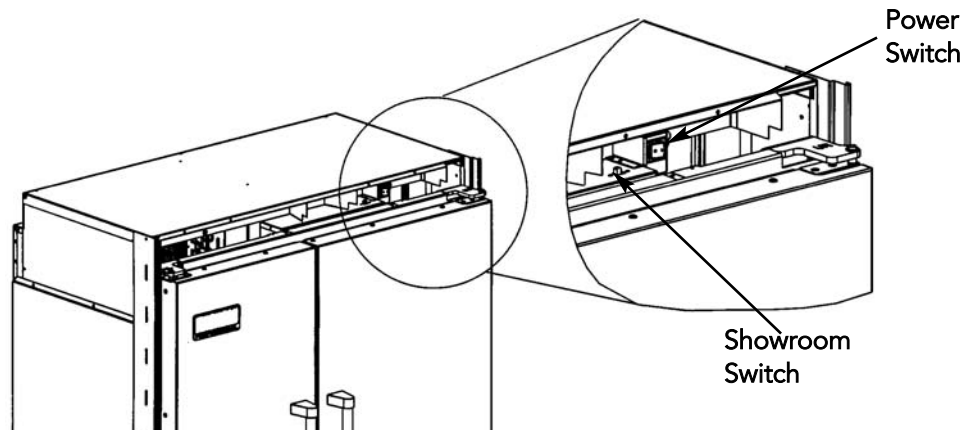

4. Remove cabinet side trim that is mounted on the left hand side of the unit that is to be installed on the right side of the installation. Replace this side trim with the "Z" shaped side trim and shim included in the full length grille kit.

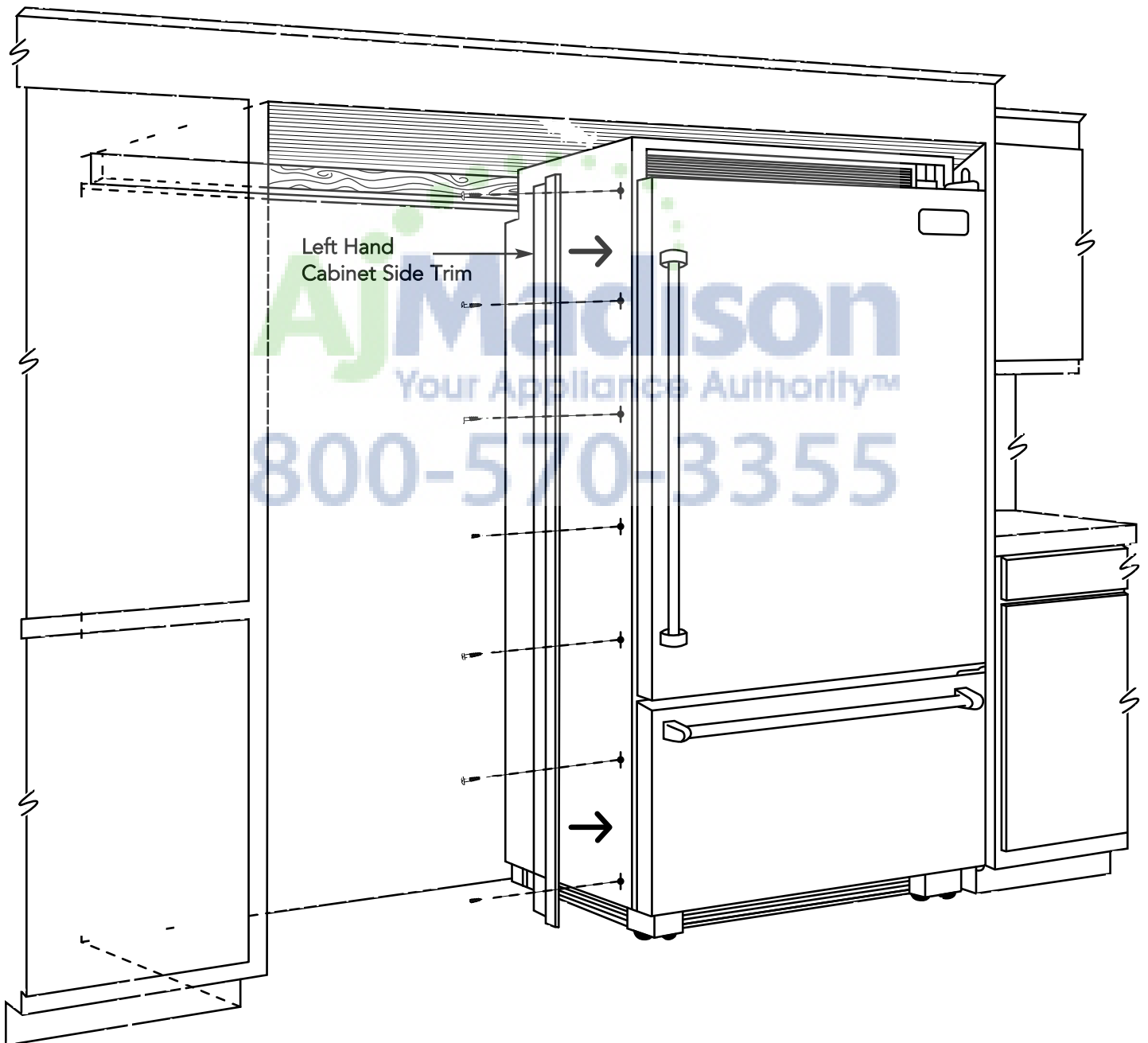

5. Remove cabinet side trim that is mounted on the right hand side of the unit that is to be installed on the left side of the installation. Replace this side trim with the connection "J" shaped side trim and shim included in the full length grille kit.
6. Place 1" (2.5 cm) spacer material on either left or right hand unit as shown on next page. The spacer material should be located off the bottom of the unit and should not extend the entire height of the unit.
7. Engage the right hand unit's left side trim into the J-shaped portion of the left side unit's right side trim.

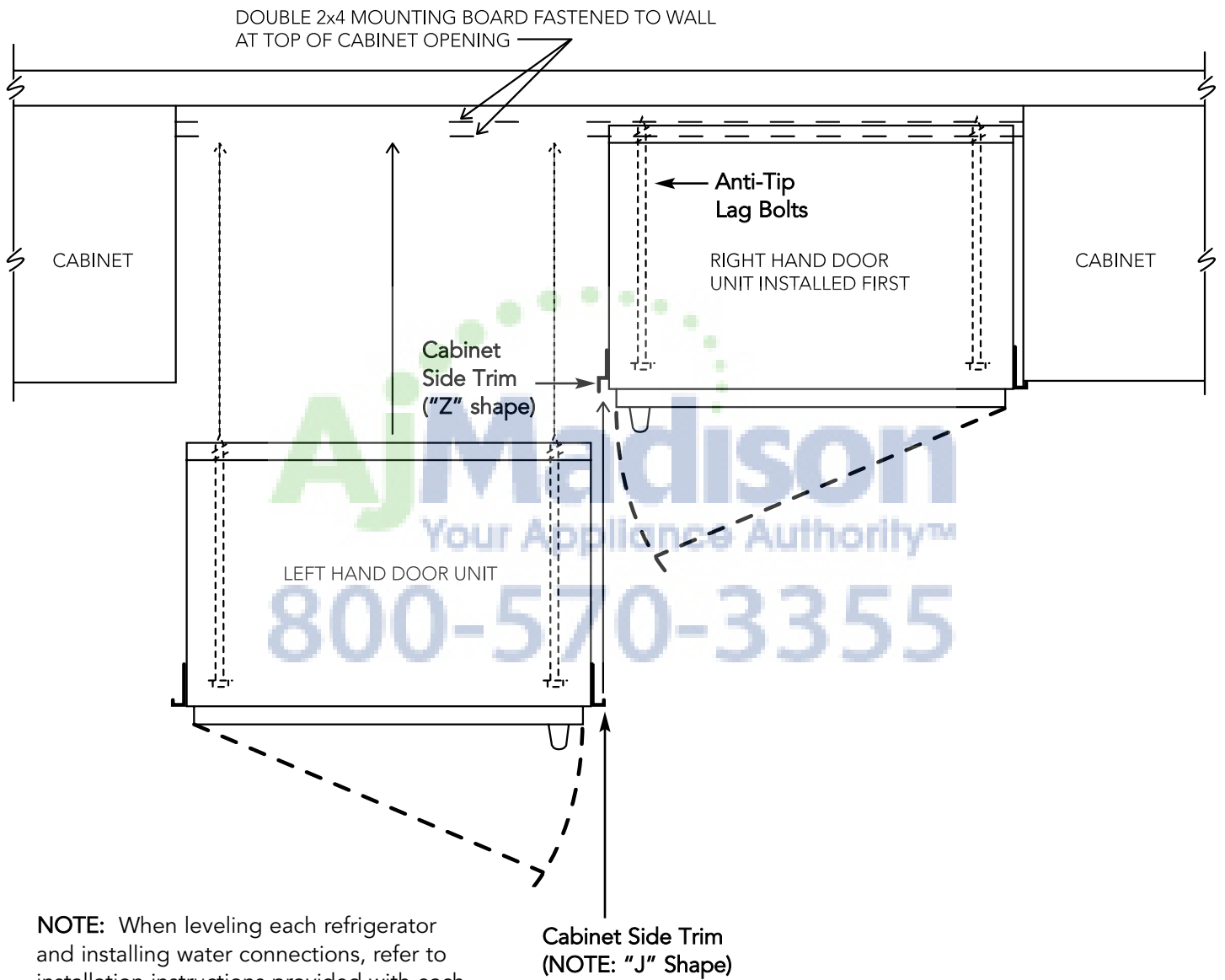

**NOTE:** When leveling each refrigerator and installing water connections, refer to installation instructions provided with each unit.

8. Assemble air ducts to 72" grille using the supplied 15 screws removed in step 2c.
9. Remove 72" center grille blade by lifting up and pulling forward.
10. Insert air ducts and 72" grille into refrigerators. Screw air ducts into units with four screws per unit.

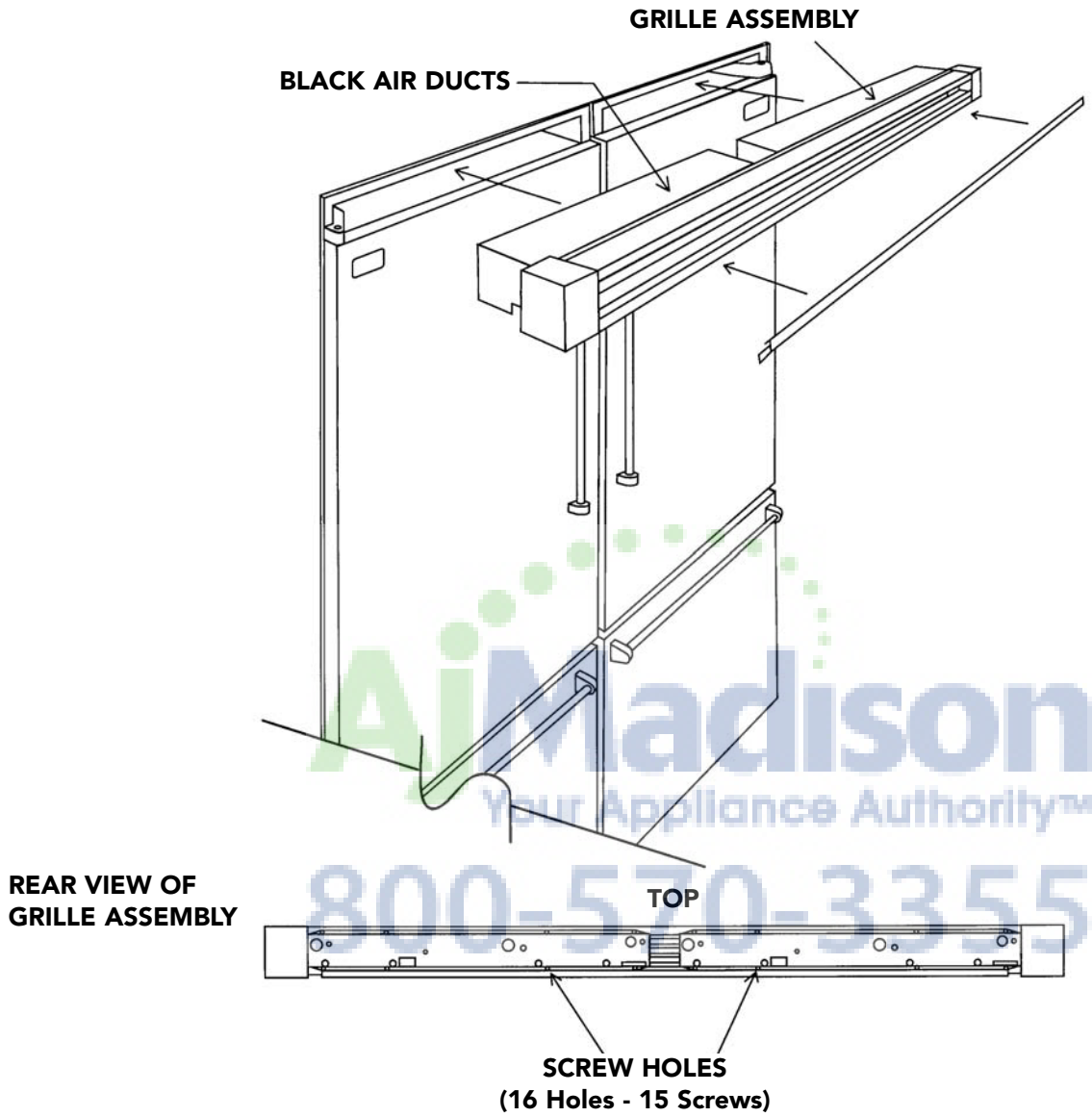

# GRILLE ASSEMBLY/INSTALLATION PROFESSIONAL MODEL PBRTGK72SS

Before moving the refrigerators in place, confirm the finished dimensions, electrical, and plumbing locations, minimum door clearances, and door panel installations are accurate. (See Installation Instructions provided with refrigerators).

1. Position refrigerators in front of cutout.
2. Remove the top air grille assemblies from both of the units
  - a. Remove full length center grille blade by lifting up and pulling forward.
  - b. Remove the grille/end cap assembly by removing two (2) screws.
  - c. Remove grille brackets by removing four (4) screws in each grille assembly.

REAR VIEW OF  
GRILLE ASSEMBLY



TOP VIEW OF GRILLE ASSEMBLY

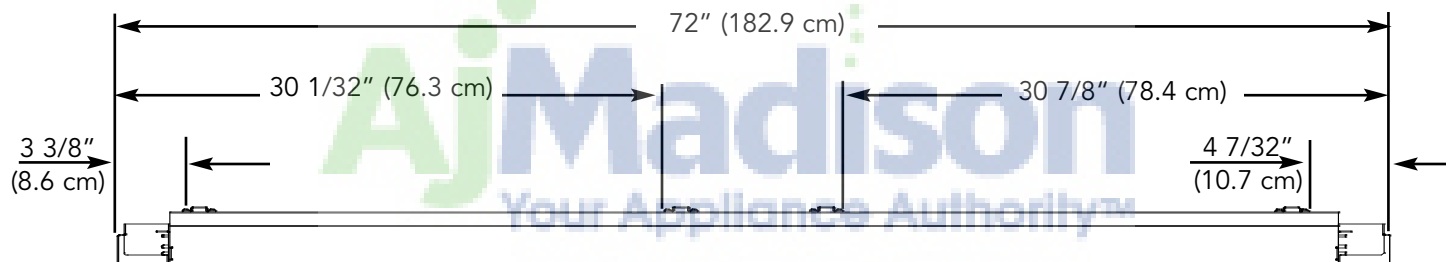

800-570-3355

3. Verify operation by plugging in power cord. **Power switch will be shipped in the ON position and showroom switch will be in the ON position.** (If showroom switch is switched to the "OFF" position, showroom mode is engaged and power is shut off to the compressor. This mode is for showroom display only.)

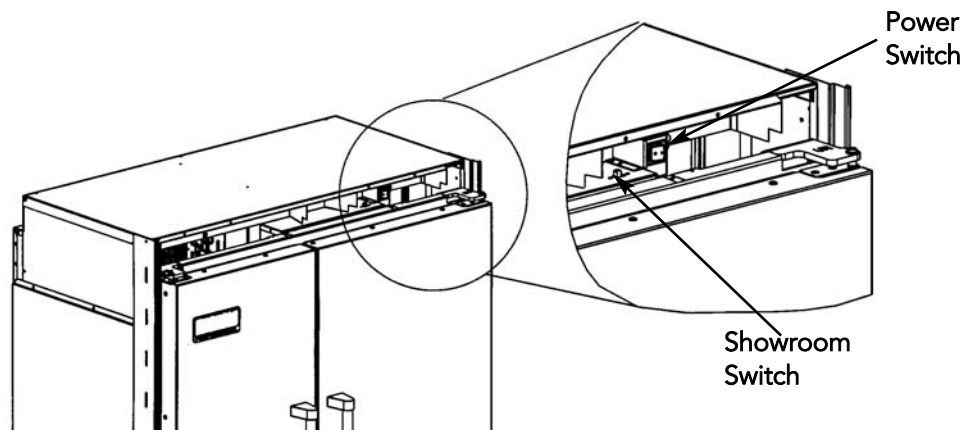

4. Remove cabinet side trim that is mounted on the left hand side of the unit that is to be installed on the right side of the installation. Replace this side trim with the "Z" shaped side trim and shim included in the full length grille kit.
5. Remove cabinet side trim that is mounted on the right hand side of the unit that is to be installed on the left side of the installation. Replace this side trim with the connection "J" shaped side trim and shim included in the full length grille kit.
6. Place 1" (2.5 cm) spacer material on either left or right hand unit as shown on next page. The spacer material should be located off the bottom of the unit and should not extend the entire height of the unit.
7. Engage the right hand unit's left side trim into the J-shaped portion of the left side unit's right side trim.

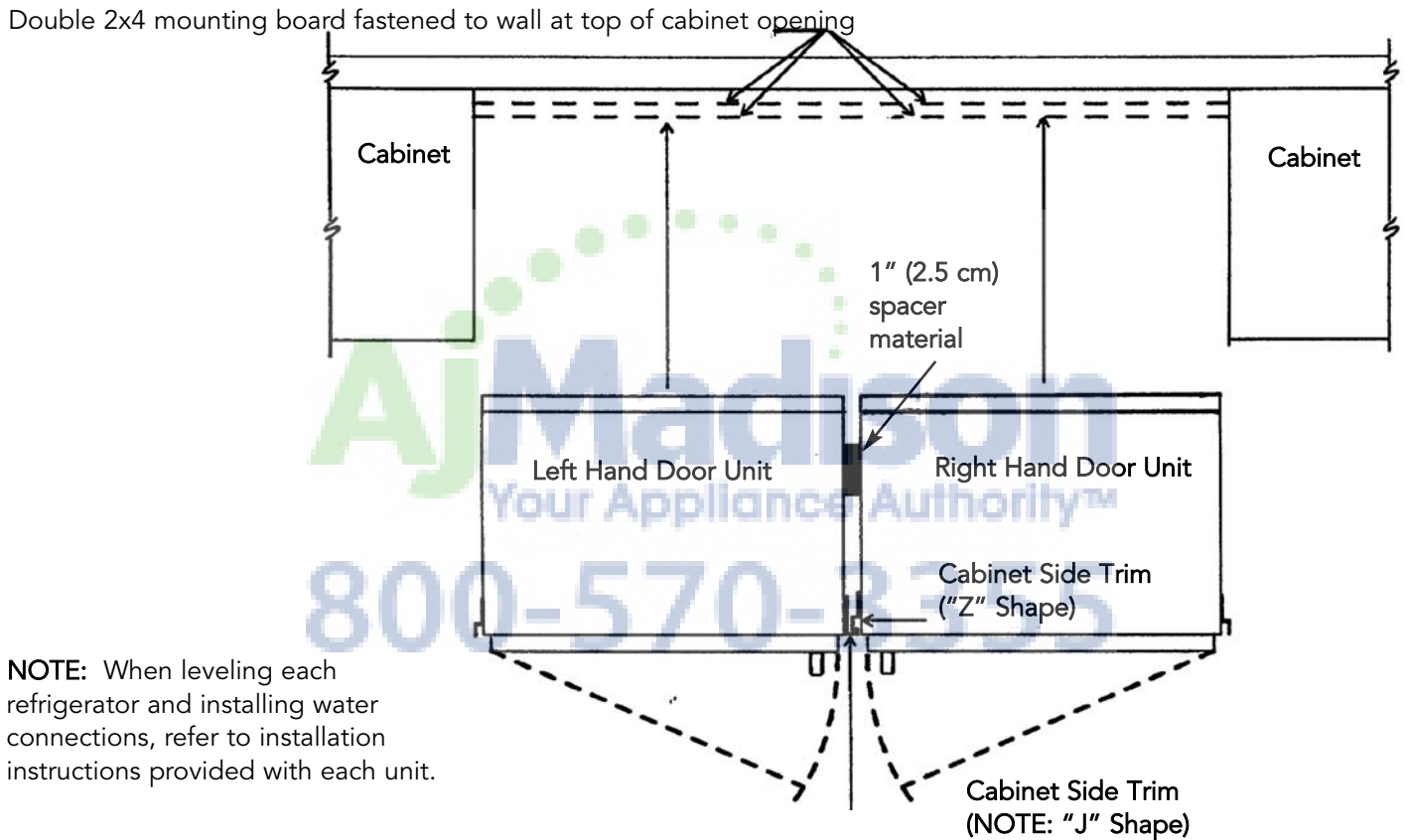

**NOTE:** When leveling each refrigerator and installing water connections, refer to installation instructions provided with each unit.

8. Assemble grille brackets to 72" grille using the 16 screws removed in step 2c.
9. Remove 72" center grille blade by lifting up and pulling forward.
10. Insert 72" grille into refrigerators. Screw 72" grille assembly into units with (4) screws removed in step 2b.

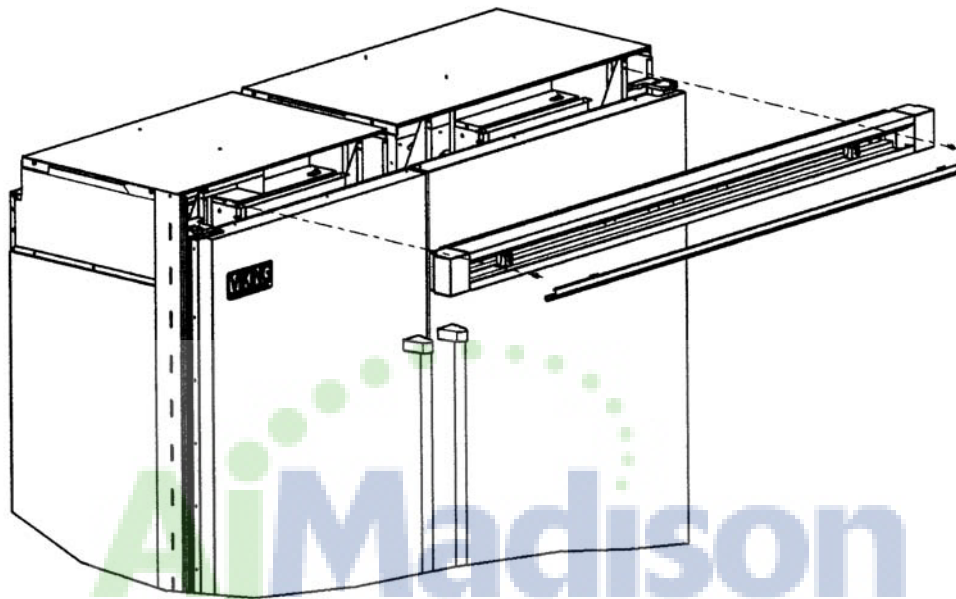

**AjMadison**  
Your Appliance Authority™  
800-570-3355



Viking Range Corporation  
111 Front Street • Greenwood, Mississippi 38930 USA • (662) 455-1200

Specifications subject to change without notice  
<http://www.vikingrange.com>