



Professional Custom Series Freestanding Dual Fuel Self-Clean 30"/36"W. Sealed Burner Range

Standard Features & Accessories

All models include

- **Exclusive** VSH™ (Vari-Simmer to High) Patented Sealed Burner System
 - o Four 15,000 BTU burners
- **Exclusive** VariSimmer™ setting for all burners
- **Exclusive** all burners equipped with SureSpark™ Ignition System for consistent and reliable ignition every time
- **Exclusive** one piece tooled and porcelainized cooking surface for easy clean up
- **Exclusive** patent-pending Vari-Speed Dual Flow™ convection system has the largest convection fan in the industry; the 8 1/2" fan works bi-directionally for maximum airflow and excellent cooking results
- Concealed 10-pass dual bake element provides precise temperature control
- Extra large Gourmet Glo™ glass enclosed infrared broiler provides superior broiling performance
- Rapid Ready™ Preheat provides one of the fastest preheat times – so your oven is ready to begin cooking when you are
- Oven has six porcelain coated rack supports and comes standard with one TruGlide™ full extension oven rack and two standard oven racks
- Three strategically located oven lights provide maximum visibility
- Heavy-duty broiler pan and tray with rack provide more roasting and broiling options
- High performance cooking modes include Bake, Convection Bake, TruConvec™ convection cooking, Convection Roast, Hi, Medium, and Low Broil, and Convection Broil
- Shipped standard with stainless steel island trim

Model Options

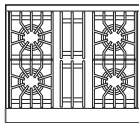

VDSC530-4B*
30"W. Four-Burner Range

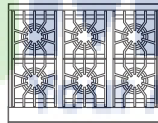

VDSC536-6B*
36"W. Six-Burner Range

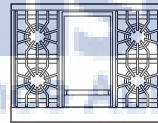

VDSC536-4G*
36"W. Four-Burner/Griddle Range

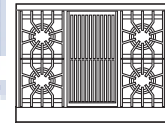

VDSC536-4Q*
36"W. Four-Burner/Grill Range

FINISH DETAILS FOR ALL MODELS

- Stainless Steel (SS), Black (BK), White (WH), Metallic Silver (MS), Graphite Gray (GG), Stone Gray (SG), Taupe (TP), Biscuit (BT), Cotton White (CW), Oyster Gray (OG), Golden Mist (GM), Lemonade (LE), Sage (SA), Mint Julep (MJ), Sea Glass (SE), Iridescent Blue (IB), Viking Blue (VB), Pumpkin (PM), Racing Red (RR), Apple Red (AR), Burgundy (BU), Plum (PL), Chocolate (CH), and Cobalt Blue (CB).
 - o Finish designates door front, lower front panel, and side panels.
- White (WH)
 - o Finish designates door front, lower front panel, side panels, porcelain grate supports, porcelain center worktop, and knobs/switches.
 - o Has black porcelain grates and black porcelain burner caps.
- All finishes have stainless steel handle/chrome-plated brackets and stainless steel drip tray pull, control panel, and landing ledge.
- Brass Accent Option (BR)—nameplate, handle, end caps, knob bezels. Brass components have a durable protective coating for maintenance-free normal use.

*Shown throughout with island trim. See **Installation Notes & Accessories** for details.

ORDERING INSTRUCTIONS

First specify model number, and then color code (VDSC530-4BSS). If ordering optional brass accent, specify code at end (VDSC530-4BSSBR). If ordering optional LP conversion, specify code at end (VDSC530-4BSSBRLP).





Professional Custom Series Freestanding Dual Fuel Self-Clean 30"/36"W. Sealed Burner Range

Standard Features & Accessories

30"W. 4B models include

- Convection oven capacity:
 - Overall capacity—4.7 cu. ft. (25-5/16"W. x 16-1/2"H. x 19-1/2"D.)
 - AHAM Standard oven capacity—4.1 cu. ft. (25-5/16"W. x 16-1/2"H. x 16-13/16"D.)
 - Four 15,000 BTU brass sealed burners with porcelain/cast iron caps and automatic ignition/re-ignition
 - Center grate allows movement of cooking vessels across entire top surface
- Shipped standard with heavy-duty metal knobs with stainless steel finish
- Shipped with stainless steel island trim*

36"W. models include

- Convection oven capacity:
 - Overall capacity—5.6 cu. ft. (30-5/16"W. x 16-1/2"H. x 19-1/2"D.)
 - AHAM Standard capacity—4.9 cu. ft. (30-5/16"W. x 16-1/2"H. x 16-13/16"D.)

36"W. 6B models include

- **Exclusive** one TruPower Plus™ 18,500 BTU burner (front right burner)
- Five 15,000 BTU brass sealed burners with porcelain/cast iron caps and automatic ignition/re-ignition

36"W. 4G models include

- Four 15,000 BTU brass sealed burners with porcelain/cast iron caps and automatic ignition/re-ignition

- 12"W. thermostatically controlled steel griddle/simmer plate
- Cast aluminum removable grease trough holds 2-1/2 cups of liquid
- **36"W. 4Q models include**
- Four 15,000 BTU brass sealed burners with porcelain/cast iron caps and automatic ignition/re-ignition
- 12"W. grill with flavor generator plates and automatic ignition/re-ignition
- **Exclusive** two-piece removable porcelainized drip pan holds three quarts of liquid

Model Options

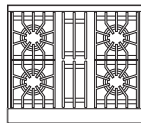

VDSC530-4B*
30"W. Four-Burner Range

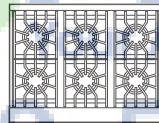

VDSC536-6B*
36"W. Six-Burner Range

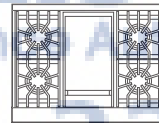

VDSC536-4G*
36"W. Four-Burner/Griddle Range

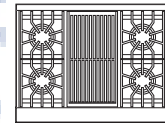

VDSC536-4Q*
36"W. Four-Burner/Grill Range

FINISH DETAILS FOR ALL MODELS

- Stainless Steel (SS), Black (BK), White (WH), Metallic Silver (MS), Graphite Gray (GG), Stone Gray (SG), Taupe (TP), Biscuit (BT), Cotton White (CW), Oyster Gray (OG), Golden Mist (GM), Lemonade (LE), Sage (SA), Mint Julep (MJ), Sea Glass (SE), Iridescent Blue (IB), Viking Blue (VB), Pumpkin (PM), Racing Red (RR), Apple Red (AR), Burgundy (BU), Plum (PL), Chocolate (CH), and Cobalt Blue (CB).
 - Finish designates door front, lower front panel, and side panels.
- White (WH)
 - Finish designates door front, lower front panel, side panels, porcelain grate supports/burner bowls, and black knobs/switches.
- Has black porcelain grates, black porcelain burner caps, black porcelain grate supports/burner bowls, and black knobs/switches.
- All finishes have stainless steel handle/chrome-plated brackets and stainless steel drip tray pull, control panel, and landing ledge.
- Brass Accent Option (BR)—nameplate, handle, end caps, knob bezels. Brass components have a durable protective coating for maintenance-free normal use.
- Has black porcelain grates and black porcelain burner caps.

*Shown throughout with island trim. See **Installation Notes & Accessories** for details.

ORDERING INSTRUCTIONS

First specify model number, and then color code (VDSC530-4BSS). If ordering optional brass accent, specify code at end (VDSC530-4BSSBR). If ordering optional LP conversion, specify code at end (VDSC530-4BSSBRLP).





Professional Custom Series Freestanding Dual Fuel Self-Clean 30"/36"W. Sealed Burner Range

Dimensions & Specifications

PRODUCT DIMENSIONS & DOOR SWING



VDSC530-4B
30"W. Four-Burner Range



VDSC536-6B
36"W. Six-Burner Range



VDSC536-4G
36"W. Four-Burner/Griddle Range



VDSC536-4Q
36"W. Four-Burner/Grill Range

★ Please see Installation Notes & Accessories for important installation information including backguard, high-shelf, island trim, and curb base front.



Star-K Kosher Certification for use on the Jewish Sabbath or Jewish holidays

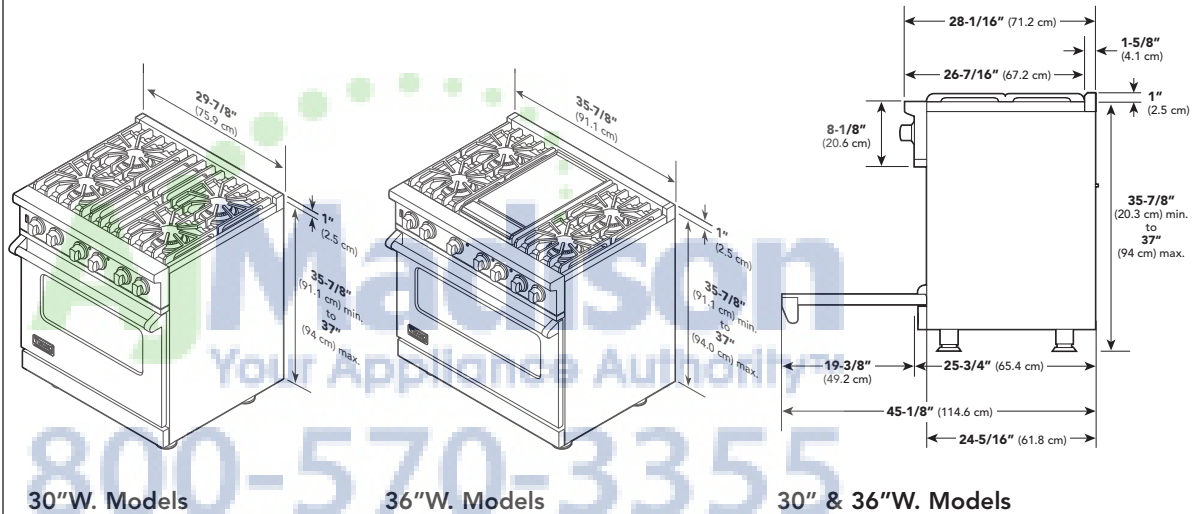

	VDSC530-4B	VDSC536-6B	VDSC536-4G	VDSC536-4Q
Overall width	29-7/8" (75.9 cm)	35-7/8" (91.1 cm)	35-7/8" (91.1 cm)	35-7/8" (91.1 cm)
Overall height				
Base height				
To top of grate support		35-7/8" (91.1 cm) min. to 37" (94.0 cm) max.		
Legs adjust (with "spindles" fully extended)		1-1/8" (2.9 cm)		
Additions to base height				
To top of island trim		Add 1" (2.5 cm)		
To top of 8" backguard		Add 8" (20.3 cm)		
To top of high-shelf		Add 23-1/2" (59.7 cm)		
Overall depth (from rear)				
To end of side panel		24-5/16" (61.8 cm)		
To front of door		25-3/4" (65.4 cm)		
To end of landing edge		28-1/16" (71.2 cm)		
To end of door handle		28-11/16" (72.9 cm)		
Oven				
Interior width	25-5/16" (64.6 cm)	30-5/16" (79.5 cm)	30-5/16" (79.5 cm)	30-5/16" (79.5 cm)
Interior height		16-1/2" (41.9 cm)		
Interior depth		Overall - 19-1/2" (49.5 cm) AHAM - 16-13/16" (42.7 cm)		
Overall interior size	Overall 4.7 cu. ft. AHAM 4.1 cu. ft.	Overall 5.6 cu. ft. AHAM 4.9 cu. ft.	Overall 5.6 cu. ft. AHAM 4.9 cu. ft.	Overall 5.6 cu. ft. AHAM 4.9 cu. ft.





Professional Custom Series Freestanding Dual Fuel Self-Clean 30"/36"W. Sealed Burner Range

Dimensions & Specifications

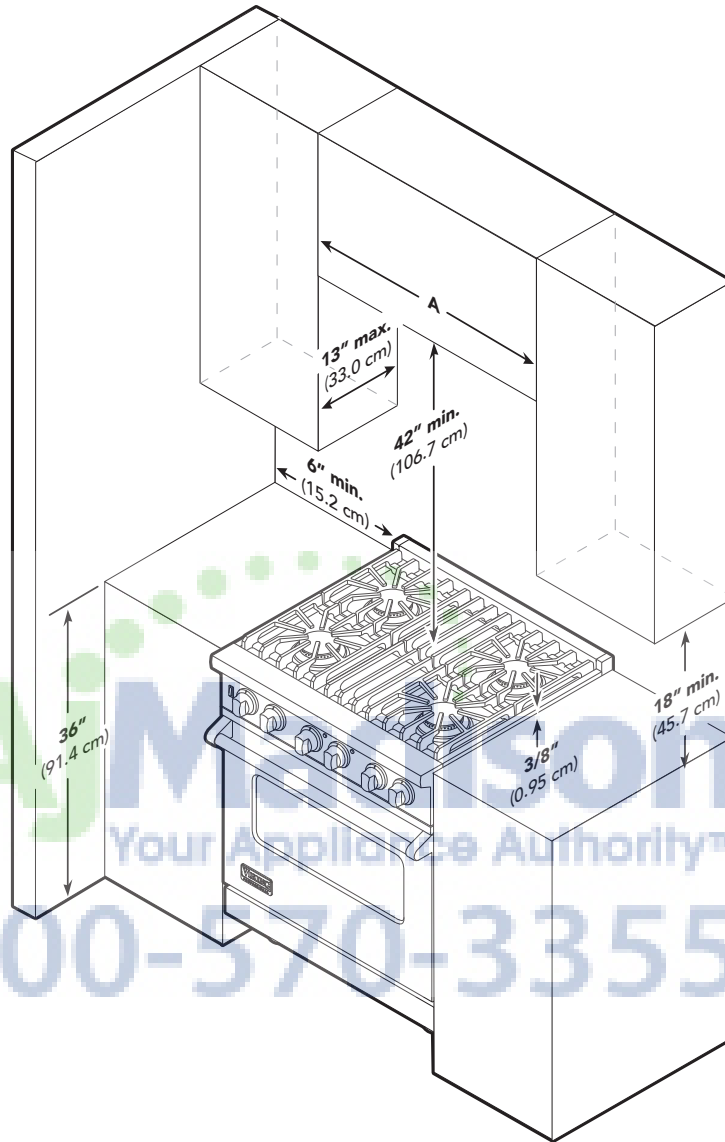

A	
30"W.	29-7/8" (75.9 cm)
36"W.	35-7/8" (91.1 cm)

Minimum clearances from adjacent combustible construction

- Cooking surface and below, i.e., 36" (91.4 cm) and below
 - o Sides—0"
 - o Rear—0" with backguard or high-shelf; 0" with island trim and non-combustible rear wall; 6" (15.2 cm) with island trim and combustible rear wall
 - o Top grate support—36" (91.4 cm)
- Above cooking surface, i.e., above 36" (91.4 cm)
 - o Sides—6" (15.2 cm)
 - o Within 6" (15.2 cm) side clearance, wall cabinets no deeper than 13" (33.0 cm) must be minimum 18" (45.7 cm) above cooking surface

- o Wall cabinets directly above product must be minimum 42" (106.7 cm) for sealed top burners above cooking surface
- Use range only with factory supplied legs
 1. This range may be installed directly adjacent to existing 36" (91.4 cm) high base cabinets. **Important:** The top grate support **must** be 3/8" (0.95 cm) above the adjacent base cabinet countertop. This may be accomplished by raising the unit using the adjustment spindles on the legs.
 2. The range **cannot** be installed directly adjacent to sidewalls, tall cabinets, tall appliances, or other side vertical surfaces above 36" (91.4 cm) high.

- There must be a minimum of 6" (15.2 cm) side clearance from the range to such combustible surfaces above the 36" (91.4 cm) counter height.
3. Within the 6" (15.2 cm) side clearance to combustible vertical surfaces above 36" (91.4 cm), the maximum wall cabinet depth must be 13" (33.0 cm) and wall cabinets within this 6" (15.2 cm) side clearance must be 18" (45.7 cm) above the 36" (91.4 cm) high countertop.
 4. Wall cabinets above the range must be a minimum of 42" (106.7 cm) above the range cooking surface for the full width of the range. This minimum height requirement does not apply if a rangehood is installed over the cooking surface.





Professional Custom Series Freestanding Dual Fuel Self-Clean 30"/36"W. Sealed Burner Range

Installation Requirements

ACCESS REQUIREMENTS

UTILITY REQUIREMENTS



GAS

- Shipped natural or LP/Propane gas; field convertible with conversion kit (purchased separately)
- Accepts standard residential 1/2" (1.3 cm) ID gas service line
- Gas manifold pressure
 - o Natural gas 5.0" W.C.P.
 - o LP/Propane 10.0" W.C.P.



ELECTRICAL

- Electrical connection box on product for hardwire direct; connect with

- locally supplied 3-wire, flexible cord rated or "pigtail" rated 40 amp 125-250 VAC min.; must be agency-approved for use with household electric ranges.
- Check your national and local codes regarding this unit.
 - Maximum amp usage—240 – 208 VAC/60 Hz
 - o 4B
 - 240V—25.4 amps
 - 208V—22.9 amps

- o 6B/4G/4Q

- 240V—28.5 amps
- 208V—24.7 amps



PLUMBING

Not applicable

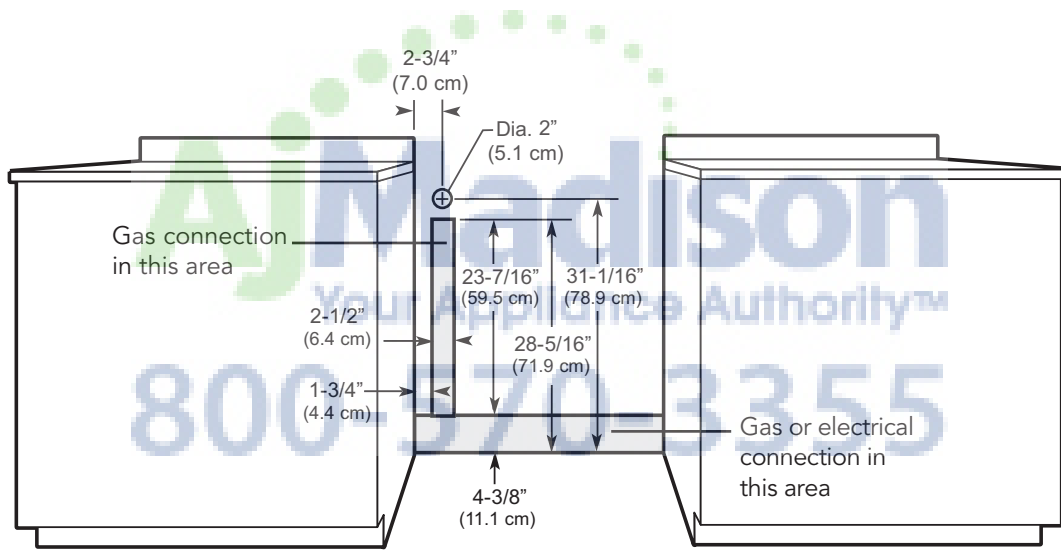

Note: Ground plug and electrical wire toward the direction of the electrical outlet.

	VDSC530-4B	VDSC536-6B	VDSC536-4G	VDSC536-4Q
Surface burner rating				
Surface burners	15,000 BTU Nat. (4.4 kW)/ 12,500 BTU LP (3.7 kW)	15,000 BTU Nat. (4.4 kW)/ 12,500 BTU LP (3.7 kW)	15,000 BTU Nat. (4.4 kW)/ 12,500 BTU LP (3.7 kW)	15,000 BTU Nat. (4.4 kW)/ 12,500 BTU LP (3.7 kW)
Surface burners (front right)		18,500 BTU Nat. (5.4 kW)/ 16,600 BTU LP (4.9 kW)		
One griddle			15,000 BTU Nat. (4.4 kW)/ 12,500 BTU LP (3.7 kW)	
One grill				18,000 BTU Nat. (5.3 kW)/ 16,000 BTU LP (4.7 kW)





Professional Custom Series Freestanding Dual Fuel Self-Clean 30"/36"W. Sealed Burner Range

✦ Installation Notes & Accessories

A backguard, high-shelf, or island trim must be used for all installations.

Island Trim

- Stainless Steel (SS)
- Coordinates with all finishes
- For island/peninsula installation
- Can replace backguard if wall is non-combustible
- Included and shipped automatically with 30"W. and 36"W. ranges.

Model	Description	Approx. ship wt. lbs. (kg)
P30TII	30"W. island trim	10 (4.5)
P36TII	36"W. island trim	11 (5.0)

8"H. Backguard

- Stainless Steel (SS)
- Coordinates with all finishes

Model	Description	Approx. ship wt. lbs. (kg)
P30BG8	30"W. backguard	14 (6.3)
P36BG8	36"W. backguard	17 (7.7)

High-shelf

- Stainless Steel (SS)
- Coordinates with all finishes
- Shelf comes attached to a 24"H. backguard

Model	Description	Approx. ship wt. lbs. (kg)
B30HS24	30"W. high-shelf	45 (20.3)
B36HS24	36"W. high-shelf	50 (22.5)

Countertop Side Trim

- Stainless Steel (SS)
- Coordinates with all finishes
- One pair of trim
- Installs on side of unit; overlaps countertop

Model	Description	Approx. ship wt. lbs. (kg)
P24CST	24"D. side trim	2 (0.9)

Countertop Rear Trim

- Stainless Steel (SS)
- Coordinates with all finishes

Model	Description	Approx. ship wt. lbs. (kg)
P30CRT	30"W. countertop rear trim	2 (0.9)
P36CRT	36"W. countertop rear trim	2 (0.9)





Professional Custom Series Freestanding Dual Fuel Self-Clean 30"/36"W. Sealed Burner Range

✦ Installation Notes & Accessories

Curb Base Front

- Stainless Steel (SS)
- Coordinates with all finishes
- Front only
- Conceals range legs
- Completely assembled
- Easily clips onto range legs after range is installed

Custom Curb Base Front

- Remove stainless steel front and recycle
- Conceals range legs
- Attach locally supplied trim
- Completely assembled
- Easily clips onto range legs after range is installed
- Provides drop-in range look

Model	Description	Approx. ship wt. lbs. (kg)
P30CBF4	30"W. curb base front	9 (4.1)
P36CBF4	36"W. curb base front	10 (4.5)

LP/Propane Conversion Kit

- Allows for field conversion of range from natural gas to LP

Model	Description	Approx. ship wt. lbs. (kg)
LPKPDF	Natural to LP/propane conversion kit	2 (0.9)



Compliance Information



WARRANTY INFORMATION*

- One-year full warranty—complete product
- Ten-year limited warranty—porcelain oven and porcelain inner door panel
- Five-year limited warranty—surface burners, griddle burners, grill burners, and oven burner
- Ninety-day limited warranty—cosmetic parts such as glass, painted, and decorative items

* For complete warranty see *Use & Care Guide*. Warranty valid on Viking products shipped within the United States and Canada.

