

20AC 6012

Cooling Capacity	BTU/Hr. @ ARI 80°F – 67° At 52% Relative Humidity	60,000
Dimensions	Width (Inches) Depth (Inches) Height (Inches) Weight (Pounds) Shipping Weight	28 39 53 470 520
Electrical Characteristics	Power Supply (Volts) Power Consumption (Kilowatts) Current Consumption (Amperes) Fuse Size (Amperes) NEMA Plug Configuration Min-max Voltage Power Cord Gauge Power Cord Length (Feet)	208/230/60/1 Phase 6.1 Cooling 40 Cooling 50 6-50P 197-253 Volt 10AWG (3 Core) 10
Compressor Characteristics	Compressor Type R 22 charge (Ounces) Operating Conditions: Min-max °F	Hermetic Scroll 77 55°-105°F, 50% RH
Fan Characteristics	Evaporator: Fan Type 6 Speed Air Flow (CFM) High/Low Max. External Static Pressure (Inches Of Water Gauge) Condenser: Fan Type Air Flow (CFM) Max. External Static Pressure (Inches Of Water Gauge)	Reverse Curved 2000/1600 0.50 Reverse Curved 3000 0.50
Safety Devices	Compressor Overload Relay Fan Motor Protection Anti-freeze Thermostat Automatic Tank Shut-off (Adj. Level) Condensate Tank Capacity (Gallons) High-pressure Switch Compressor Short-cycle Protection Fan Mode Switch Automatic Restart Thermostat	Yes Yes No N/A Built In Pump Yes Yes Yes Yes Yes Digital
Miscellaneous Features	Operating Cost (Approximate/Hr.) Humidity Removed @ 60% RH (Gal/Hr.) Accommodates Condensate Pump Sound Level (Db) High/Low Max Evaporator Ducting Length*(Ft.) Max Condenser Ducting Length*(Ft.) <i>*Subtract 10 Ft. For Every 90° Bend</i>	\$0.62 4.1 Built In Pump 66/ 64 80 80

20AC 6012

Power Supply 208/230 volts 60 hertz 1 phase 40 amperes

Width 28 inches

Depth 39 inches

Height 53 inches

Weight (net/shipping) lbs 470/520

All models are backed by a 12-month warranty with 60 months for the compressor.

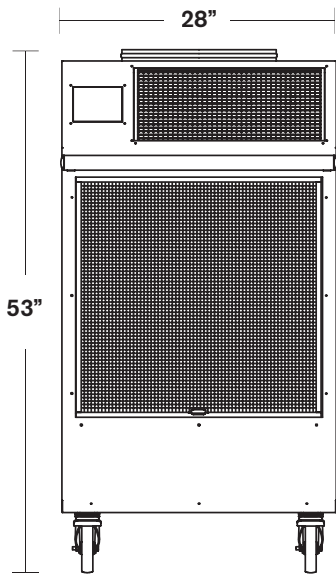

FRONT

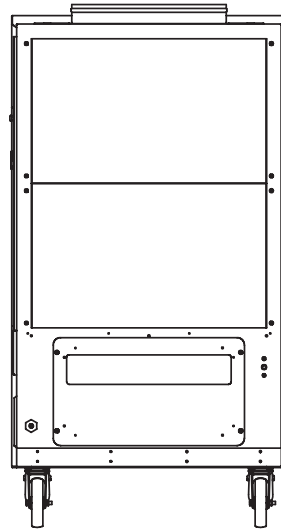

BACK

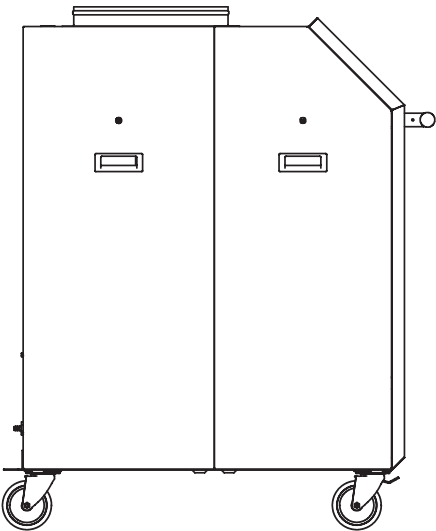

SIDE

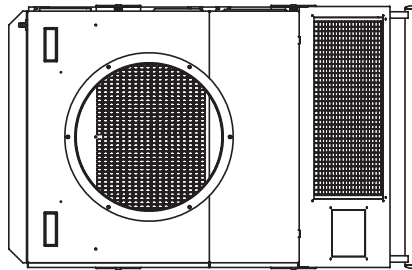

TOP

SPOT COOLERS

800.367.8675 • www.spot-coolers.com

Copyright © 2004 Spot Coolers, Inc. All rights reserved.