







Use and Care & Installation Guide

36" Vented Hood

	Safety Instructions ...Front Cover, 2
	Operating Instructions2, 3 Automatic Heat Sensor3 Controls2
	Cleaning3 Filter3 Light Bulb Replacement3

	Installation4-6 Damper/Duct Connector5 Electrical Wiring6 Filter Panel.....3, 5 Mounting Brackets5
	Consumer Services7 Important Phone Numbers7 WarrantyBack Cover

 **IMPORTANT SAFETY INFORMATION.
READ ALL INSTRUCTIONS BEFORE USING.**

SAFETY PRECAUTIONS

WARNING — TO REDUCE THE RISK OF FIRE, ELECTRIC SHOCK OR INJURY TO PERSONS, OBSERVE THE FOLLOWING:

- A. Use this unit only in the manner intended by the manufacturer. If you have questions, contact the manufacturer.
- B. Before servicing or cleaning unit, switch power off at service panel and lock the service disconnecting means to prevent power from being switched on accidentally. When the service disconnecting means cannot be locked, securely fasten a prominent warning device, such as a tag, to the service panel.
- C. Do not use this unit with any solid-state speed control device.
- D. Use with approved cord-connection kit only.
- E. This unit must be grounded.

WARNING — TO REDUCE THE RISK OF A RANGE TOP GREASE FIRE:

- A. Never leave surface units unattended at high settings. Boilovers cause smoking and greasy spillovers that may ignite. Heat oils slowly on low or medium settings.
- B. Always turn hood **ON** when cooking at high heat or when cooking flaming foods.
- C. Clean ventilating fans frequently. Grease should not be allowed to accumulate on fan or filter.
- D. Use proper pan size. Always use cookware appropriate for the size of the surface element.

(continued next page)

GE Appliances

Models: JV694 JV695 JV696 JV960



IMPORTANT SAFETY INFORMATION. READ ALL INSTRUCTIONS BEFORE USING.

SAFETY PRECAUTIONS

CAUTION — For general ventilating use only. Do not use to exhaust hazardous or explosive materials and vapors.

WARNING — **TO REDUCE THE RISK OF INJURY TO PERSONS IN THE EVENT OF A RANGE TOP GREASE FIRE, OBSERVE THE FOLLOWING*:**

- A. SMOTHER FLAMES with a close-fitting lid, cookie sheet, or metal tray, then turn off the burner. BE CAREFUL TO PREVENT BURNS. If the flames do not go out immediately, EVACUATE AND CALL THE FIRE DEPARTMENT.
- B. NEVER PICK UP A FLAMING PAN—You may be burned.
- C. DO NOT USE WATER, including wet dishcloths or towels—a violent steam explosion will result.
- D. Use an extinguisher ONLY if:
 1. You know you have a Class ABC extinguisher, and you already know how to operate it.
 2. The fire is small and contained in the area where it started.
 3. The fire department is being called.
 4. You can fight the fire with your back to an exit.

* Based on “Kitchen Firesafety Tips” published by NFPA.

WARNING — **TO REDUCE THE RISK OF FIRE, ELECTRIC SHOCK OR INJURY TO PERSONS, OBSERVE THE FOLLOWING:**

- A. Installation work and electrical wiring must be done by qualified person(s) in accordance with all applicable codes and standards, including fire-rated construction.
- B. Sufficient air is needed for proper combustion and exhausting of gases through the flue (chimney) of fuel burning equipment to prevent back drafting. Follow the heating equipment manufacturer’s guideline and safety standards such as those published by the National Fire Protection Association (NFPA), and the American Society for Heating, Refrigeration and Air Conditioning Engineers (ASHRAE), and the local code authorities.
- C. When cutting or drilling into wall or ceiling, do not damage electrical wiring and other hidden utilities.
- D. Ducted fans must always be vented to the outdoors.

WARNING — **TO REDUCE THE RISK OF FIRE, USE ONLY METAL DUCTWORK.**

- Do not attempt to repair or replace any part of your hood unless it is specifically recommended in this guide. All other servicing should be referred to a qualified technician.

READ AND FOLLOW THIS SAFETY INFORMATION CAREFULLY.

READ AND SAVE THESE INSTRUCTIONS



OPERATING INSTRUCTIONS

Always turn your hood on before you begin cooking to establish an air flow in the kitchen. Let the hood run for a few minutes to clean the air after you turn the range off. This will keep the whole kitchen cleaner.

Controls

The hood is “OFF” when the glass visor is pushed completely in.

LIGHT—The light will turn “ON” when the glass visor is pulled out approximately 1/2 inch.

BLOWER—The blower will turn “ON” when the drawer is pulled out approximately 1½ inches.

The blower speed is set using the slide control, located to the right of the drawer.

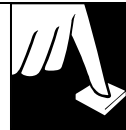

Automatic Heat Sensor

Your hood is equipped with an automatic thermostat. This thermostat is a device that will turn on or speed up the blower if it senses excessive heat above the cooking surface.

If your blower is not on, or if it is running at low speed, the thermostat will sense excessive cooking heat, override the normal blower control and turn the blower on to high speed. The blower will run until the temperature drops to normal operating level. The blower will then automatically return to its original setting.

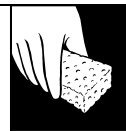

CARE AND CLEANING

WARNING: ALWAYS DISCONNECT ELECTRIC POWER SUPPLY BEFORE SERVICING HOOD.

Use a mild detergent suitable for painted surfaces. **DO NOT USE ABRASIVE CLOTH, STEEL WOOL PADS, OR SCOURING POWDERS.** Vacuum the blower to clean it. Do not immerse the blower in water.

The glass visor assembly and light lens are easily removable for cleaning:

DO NOT clean in a dishwasher.

Remove the light lens by opening the filter panel and turning the 2 metal clips holding the lens in place.

Filter

Slide the glass visor open.

Open the filter panel by turning the two clips and allowing it to swing free.

Flex the filter in the middle to remove it.

Wash and rinse the filter in a mild detergent solution.

Replace the filter before using the exhaust fan.

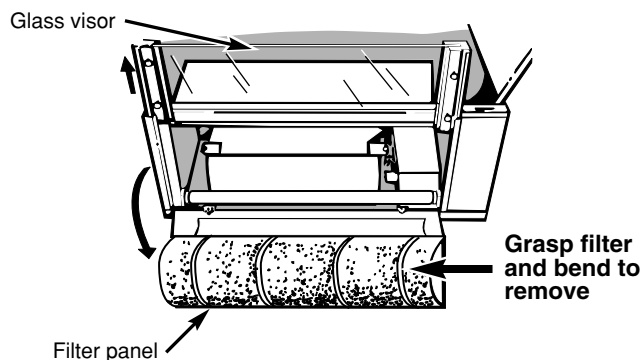
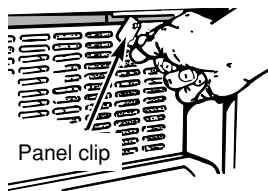

Light Bulb Replacement

This hood uses an F20T12 fluorescent tube and an FS-2 starter, which are available at most hardware stores or home centers.

If the tube flickers or does not light, check the prongs on the ends of the tube to make sure they are properly seated in the tube holders.

If the tube continues to flicker or does not light, replace the tube. Slide the tube into the holders and rotate the tube so that the prongs in the holders grip the tube and hold it in place.

If the ends of the tube light but the center does not, the starter may require replacement. The starter is located behind the filter panel on the right hand side. Install the new starter by pushing the starter in and turning it clockwise.

Stainless Steel (on some models)

Clean with warm sudsy water, a stainless steel cleaner such as Kleen King®, or an all-purpose liquid or spray cleaner. Always scrub in the direction of the grain. Rinse thoroughly with a sponge or cloth and clean water. Dry with a soft, clean cloth.

Do not use a soap-filled steel wool pad; it will scratch the surface.



INSTALLATION INSTRUCTIONS

TOOLS YOU WILL NEED



Flat blade and Phillips screwdrivers



Pencil



Duct tape

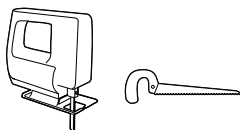

Saw (saber or keyhole)

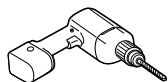

Electric Drill



Metal Snips
(in some applications)

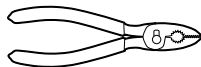

Pliers

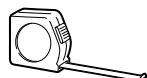

Tape measure

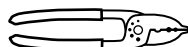

Wire stripper

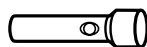

Flashlight

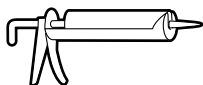

Caulking



Level

PLAN THE INSTALLATION

Caution: Remove the house fuse or open the circuit breaker before beginning the installation.

Your new hood will fit a standard 36" wide flush bottom or recessed bottom, framed or frameless kitchen cabinet which has a **minimum depth of 11" from the face to the inside of the back wall.**

The unit is ducted vertically. To change to horizontal ducting see the instructions.

For safe operation, the mounted hood must be a minimum of 18" above the cooking surface.

For easiest installation, the range hood should be installed in the cabinet before mounting the cabinet to the wall.

NOTE: Remove the glass visor from the unit before installing the hood in the cabinet to protect the visor from damage.

This hood can easily be installed by following these basic steps:

- Mark and cut out the cabinet bottom.
- Secure the hood to the cabinet.
- Mount the cabinet on the wall.
- Connect the ductwork and the power cable.

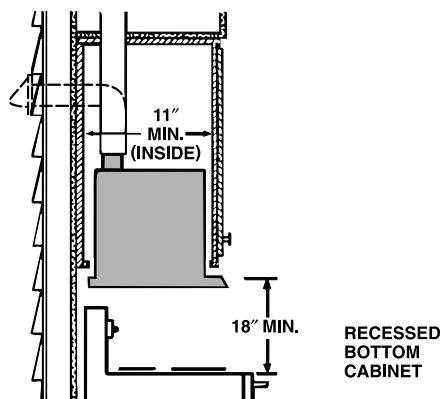
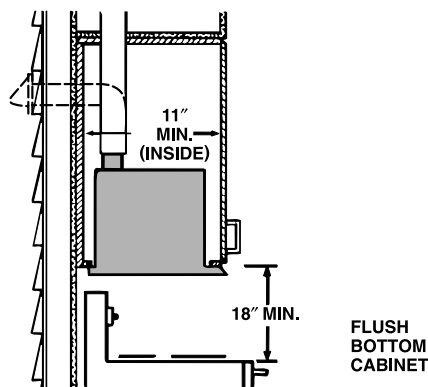

INSTALL THE HOOD

1. Mark and cut out the cabinet bottom.

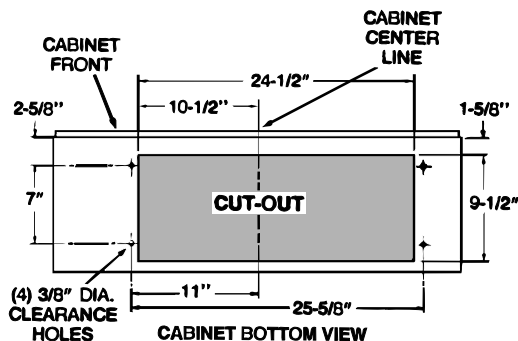

Prepare the cabinet bottom as shown above. Be sure to locate the cut-out and four holes from the front of the cabinet to assure a flush mount.

INSTALLATION INSTRUCTIONS



2. Attach the damper/duct connector.

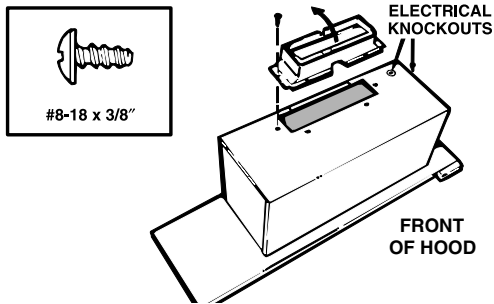

Use two (2) screws (provided) to attach the connector to the housing. The damper flap should open in the direction indicated by the arrow.

3. Remove the electrical knockout.

Choose either the top or side of the housing for the electrical cable entrance. Remove the appropriate knockout.

4. Set the housing into the opening.

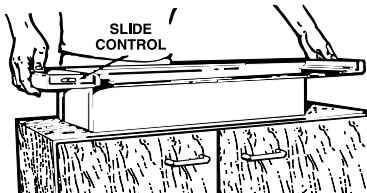

Carefully lower the housing into the cabinet opening with the slide control to the front.

5. Remove the access cover.

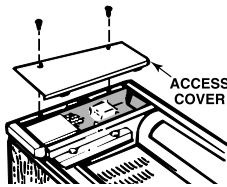

6. Open the filter panel.

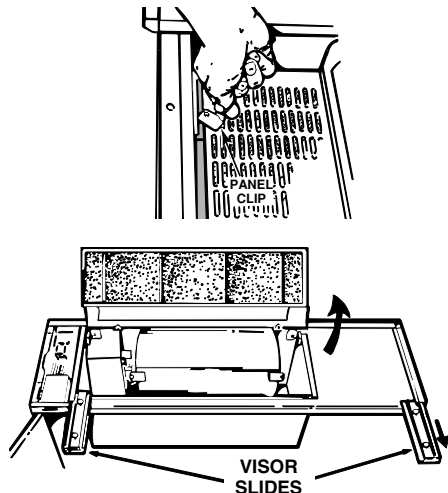

Pull the visor slides out. Rotate the panel clips and swing the panel open.

7. Install the mounting brackets.

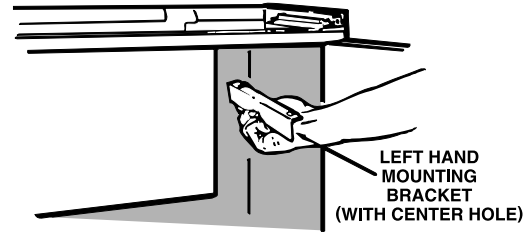

Hold the left hand mounting bracket in place on the side of the housing as shown.

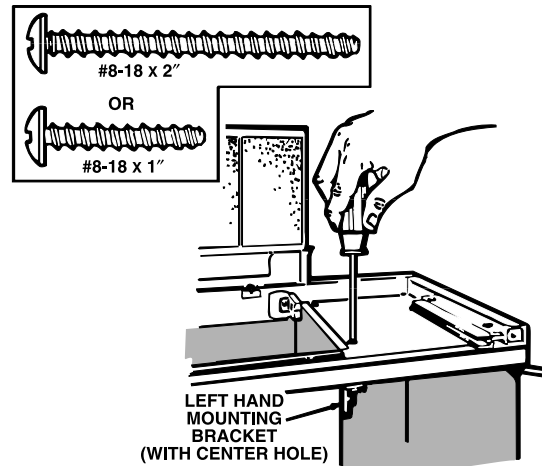

Two (2) sets of screws are provided. Use the short screws for flush bottom cabinets or long screws for recessed bottom cabinets. Insert two (2) screws through the housing and into the mounting bracket. Do not tighten screws completely.

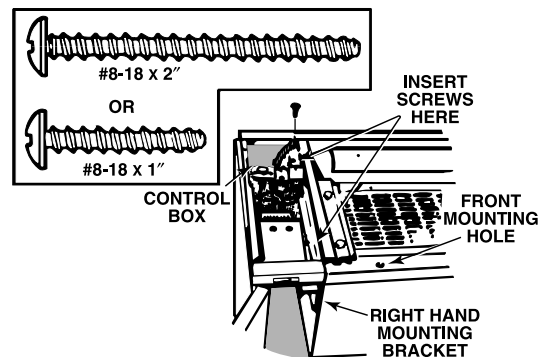

Insert two (2) screws, short or long as appropriate, through the control box and into the other mounting bracket. Do not tighten the screws completely.



INSTALLATION INSTRUCTIONS

8. Secure the hood to the cabinet.

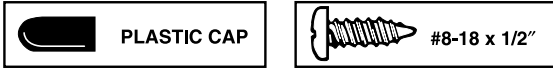

Align the hood with the sides and front edge of the cabinet. Tighten the screws in each mounting bracket. Place plastic caps (provided) over the ends of these screws from the inside of the cabinet.

Install two (2) additional screws into the cabinet bottom, through the front mounting holes along the front edge of the hood.

9. Replace the access cover.

Secure the access cover with the two (2) screws removed in step 5.

10. Mount the cabinet on the wall.

Make sure the cabinet is securely attached to the wall and/or adjoining cabinets. The mounted cabinet must be able to support the added weight of the hood.

11. Attach the ductwork and the front trim.

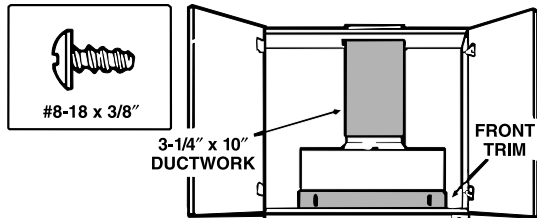

Complete the ductwork from the hood to the outside using a roof cap or elbow and wall cap. Tape all joints. Shelves may be installed if trimmed to clear the ductwork.

The front trim piece covers the gap between the housing and the front edge of the cabinet cut-out. Mount the front trim to the housing with two (2) screws (provided).

12. Connect the electrical wiring.

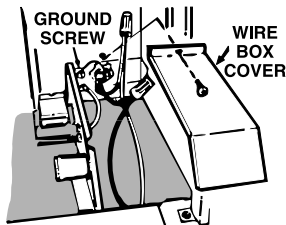

Remove the wire box cover. Attach the power cable to the hood using the proper connector. Connect black to black, white to white and green or bare wire to ground screw. Replace the wire box cover.

CAUTION: DO NOT TURN THE BREAKER ON OR INSERT THE HOUSE FUSE AT THIS TIME.

13. Install the glass visor assembly.

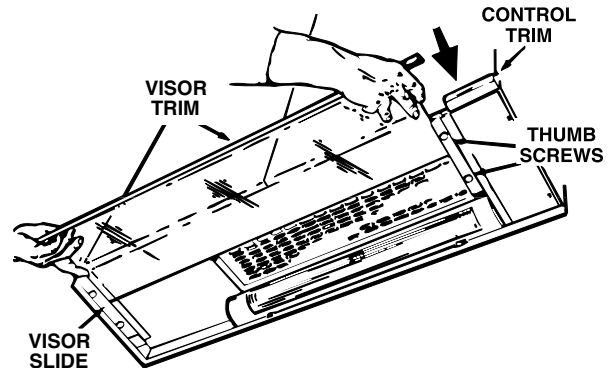

Slide the glass into the visor slides, above each visor clamp (see the illustration in step 14). Align the visor trim and tighten the thumb screws to secure the glass.

To remove the glass visor:

Simply loosen the thumb screws and pull the glass from the visor slides.

14. Fine adjustments to the visor trim position.

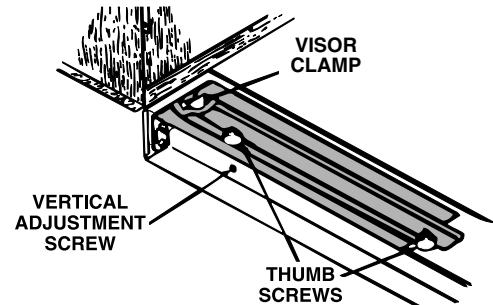

The visor slides each have a screw for adjusting the height of the visor trim, if necessary. The vertical adjustment screw allows the top and bottom edges of the visor trim to be matched with the control trim.

15. Connect the power.

16. Check operation.

We'll Be There

With the purchase of your new GE appliance, receive the assurance that if you ever need information or assistance from GE, we'll be there. All you have to do is call—toll-free!

GE Answer Center®

800.626.2000

Whatever your question about any GE major appliance, GE Answer Center® information service is available to help. Your call—and your question—will be answered promptly and courteously. And you can call any time. GE Answer Center® service is open 24 hours a day, 7 days a week.

In-Home Repair Service

800-GE-CARES (800-432-2737)

A GE consumer service professional will provide expert repair service, scheduled at a time that's convenient for you. Many GE Consumer Service company-operated locations offer you service today or tomorrow, or at your convenience (7:00 a.m. to 7:00 p.m. weekdays, 9:00 a.m. to 2:00 p.m. Saturdays). Our factory-trained technicians know your appliance inside and out—so most repairs can be handled in just one visit.

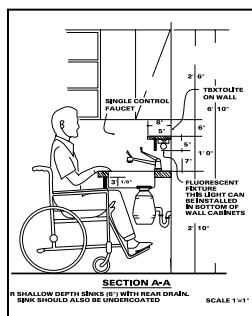

For Customers With Special Needs...

800.626.2000

Upon request, GE will provide Braille controls for a variety of GE appliances, and a brochure to assist in planning a barrier-free kitchen for persons with limited mobility. To obtain these items, free of charge, call 800.626.2000.

Consumers with impaired hearing or speech who have access to a TDD or a conventional teletypewriter may call 800-TDD-GEAC (800-833-4322) to request information or service.

Service Contracts

800-626-2224

You can have the secure feeling that GE Consumer Service will still be there after your warranty expires. Purchase a GE contract while your warranty is still in effect and you'll receive a substantial discount. With a multiple-year contract, you're assured of future service at today's prices.

Parts and Accessories

800-626-2002

Individuals qualified to service their own appliances can have parts or accessories sent directly to their home. The GE parts system provides access to over 47,000 parts...and all GE Genuine Renewal Parts are fully warranted. VISA, MasterCard and Discover cards are accepted.

User maintenance instructions contained in this guide cover procedures intended to be performed by any user. Other servicing generally should be referred to qualified service personnel. Caution must be exercised, since improper servicing may cause unsafe operation.

YOUR 36" HOOD WARRANTY

Staple sales slip or cancelled check here. Proof of original purchase date is needed to obtain service under warranty.

WHAT IS COVERED

FULL ONE-YEAR WARRANTY

For one year from date of original purchase, we will provide, free of charge, parts and service labor in your home to repair or replace **any part of the hood** that fails because of a manufacturing defect.

This warranty is extended to the original purchaser and any succeeding owner for products purchased for ordinary home use in the 48 mainland states, Hawaii and Washington, D.C. In Alaska the warranty is the same except that it is LIMITED because you must pay to ship the product to the service shop or for the service technician's travel costs to your home.

All warranty service will be provided by our Factory Service Centers or by our authorized Customer Care® servicers during normal working hours.

Should your appliance need service, during warranty period or beyond, call 800-GE-CARES (800-432-2737).

WHAT IS NOT COVERED

- Service trips to your home to teach you how to use the product.

Read your Use and Care material.

If you then have any questions about operating the product, please contact your dealer or our Customer Relations office at the address below, or call, toll free:

GE Answer Center®
800.626.2000
consumer information service

- Improper installation, delivery or maintenance.

If you have an installation problem, contact your dealer or installer. You are responsible for providing adequate electrical, exhausting and other connecting facilities as described in the Installation Instructions provided with the product.

- Replacement of the replaceable filters.
- Replacement of house fuses or resetting of circuit breakers.
- Failure of the product if it is used for other than its intended purpose or used commercially.
- Damage to product caused by accident, fire, floods or acts of God.
- Incidental or consequential damage caused by possible defects with this appliance.
- Damage caused after delivery.

Some states do not allow the exclusion or limitation of incidental or consequential damages, so the above limitation or exclusion may not apply to you. This warranty gives you specific legal rights, and you may also have other rights which vary from state to state. To know what your legal rights are in your state, consult your local or state consumer affairs office or your state's Attorney General.

Warrantor: General Electric Company

**If further help is needed concerning this warranty, write:
Manager—Customer Relations, GE Appliances, Louisville, KY 40225**

164D3333P215

49-8991-3

99 04 2887D

JV694 JV695 JV696 JV960

Printed in the United States