

ID-36C



FEATURES

Ready to be fitted with custom panels and handles to blend with cabinetry

Smart-touch controls for streamlined access to more settings

Soft-close doors and drawers

Soft-on LED lights for varying degrees of brightness

Rigorously tested in our U.S. manufacturing facilities to ensure decades of use

Exceptional 24/7 support from Madison, WI-based Customer Care team

ACCESSORIES

Egg Container

Crisper cover

Dual installation kits

Stainless steel front panels with tubular or pro handles

Stainless steel kickplate

Stainless steel pro handles

Stainless steel tubular handles

Accessories are available through an authorized Sub-Zero dealer. For local dealer information, visit subzero-wolf.com/locator.

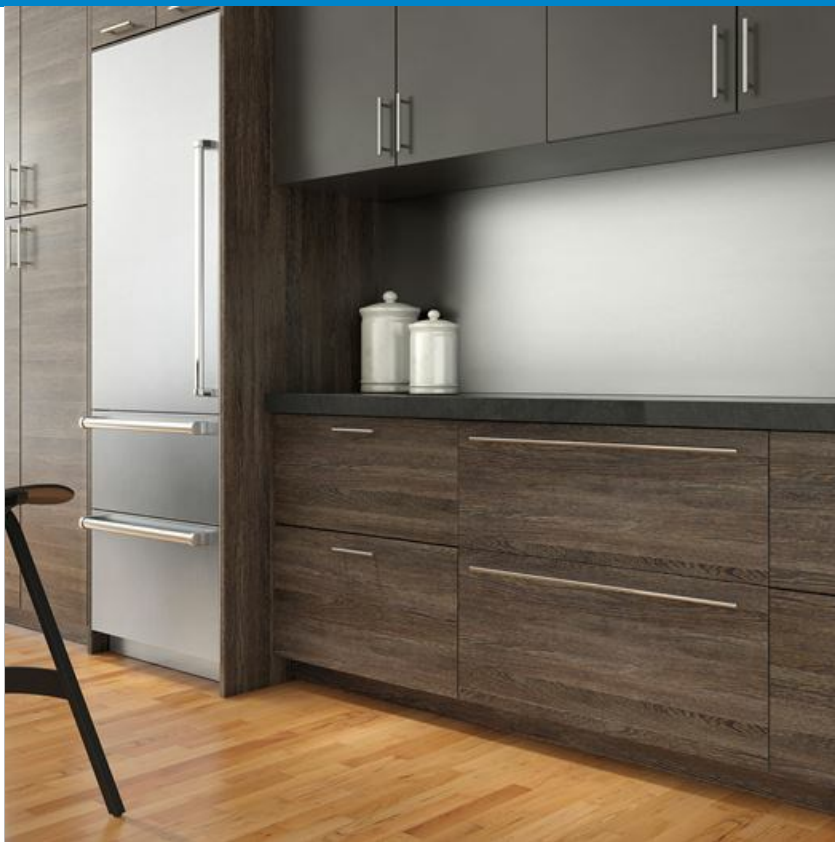

HANDLE ACCESSORIES

PRO



TUBULAR



PRODUCT DETAILS

REFRIGERATOR

- Adjustable drawer dividers

FREEZER

- Adjustable drawer dividers

PRODUCT SPECIFICATIONS

Model	ID-36C
Dimensions	36"W x 34 1/2"H x 24"D
Drawer Clearance	18 3/8"
Weight	250 lb
Refrigerator Capacity	3.4 cu ft
Freezer Capacity	2.5 cu ft
Electrical Supply	115 VAC, 60 Hz
Electrical Service	15 amp dedicated circuit
Plumbing Supply	1/4" OD copper, braided stainless steel or PEX tubing
Plumbing Pressure	35-120 psi
Receptacle	3-prong grounding-type

ELECTRICAL

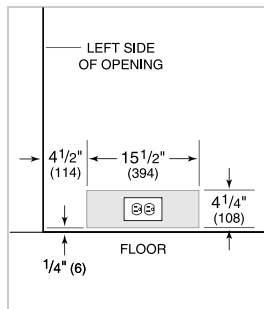

INTERIOR VIEW

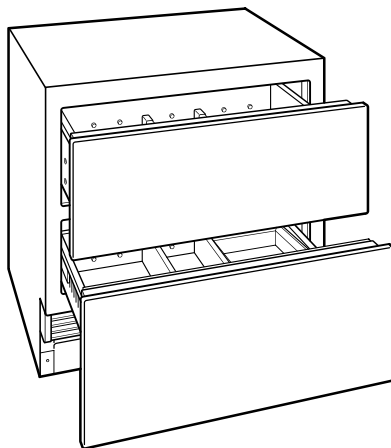

This illustration is intended for interior reference only and may not represent the exterior of the model being specified.

DIMENSIONS

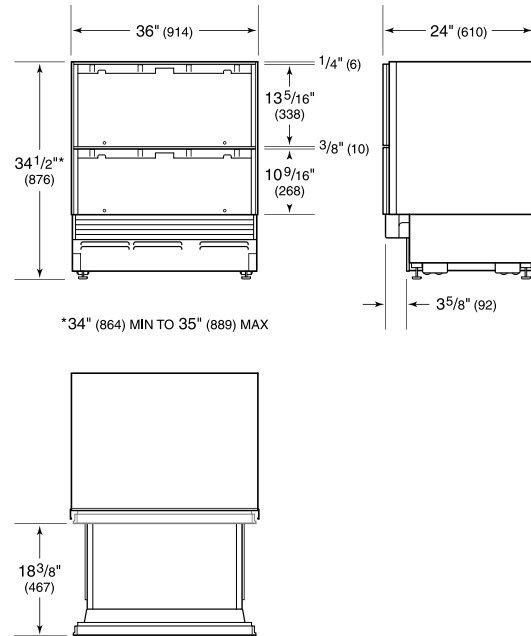

STANDARD INSTALLATION

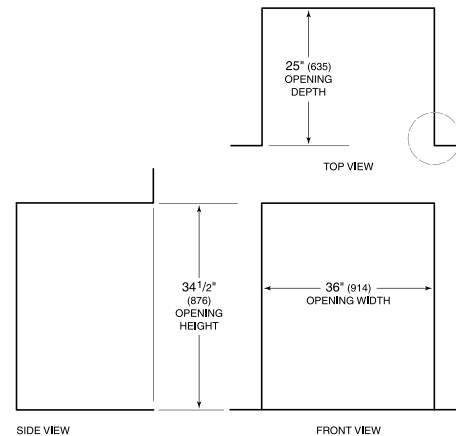

NOTE: 3 1/2" (89) finished returns will be visible and should be finished to match cabinetry.

