

Installation Instructions / Warranty

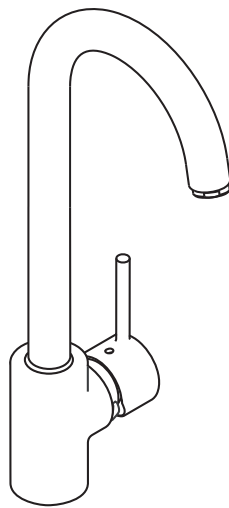

HighArc

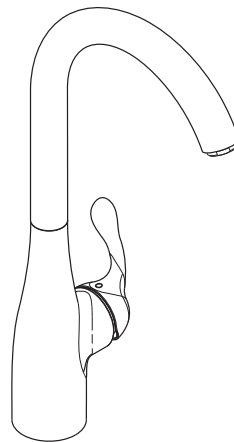

Allegro E

14801XX1

Bar Faucets

hansgrohe

English

HighArc Bar Faucets

06688XX0	Solaris E
06696XX0	Stratos E
06699XX0	Metro E
06857XX0	Talis S

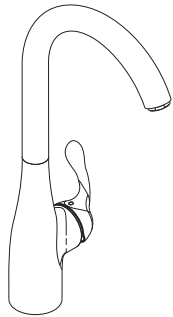

Allegro E 14801XX1
see page 5

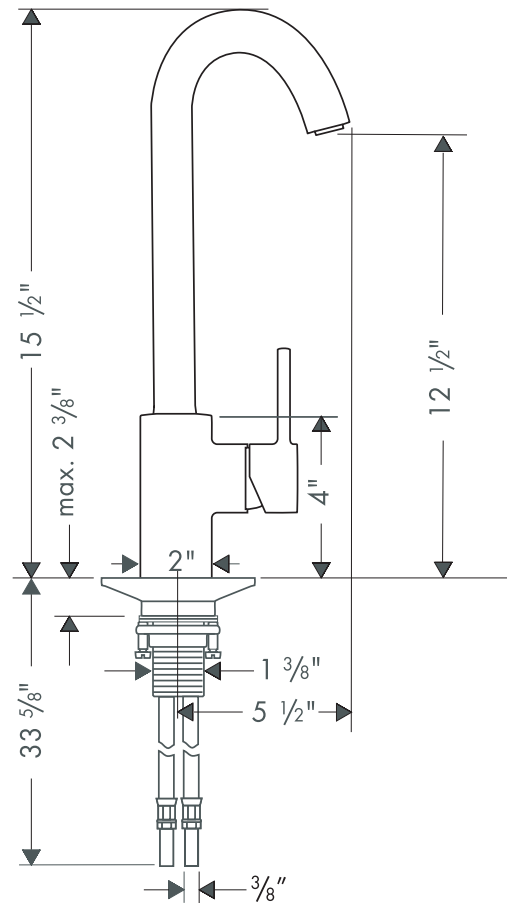

Technical Specification

Recommended water pressure	14.7 - 72.5 PSI
Recommended hot water temp.	120° - 140° F*
Hole size in mounting surface	1-1/2"
Max. mounting surface thickness	2 3/8"
Max. flow rate	1.5 GPM

*Please know and follow all applicable local codes when setting the temperature on the water heater.

Installation Considerations

- For best results, Hansgrohe recommends that this unit be installed by a licensed, professional plumber.
- Please read over these instructions thoroughly before beginning installation. Make sure that you have all tools and supplies needed to complete the installation.
- The hot and cold supply hoses connect to the stops with 3/8" compression fittings (included).
- Flush the hot and cold supplies thoroughly before installing this faucet. Debris in the water line may damage the ceramic cartridge.

Installation

Push the spout into place on the faucet. Tighten the spout set screw.

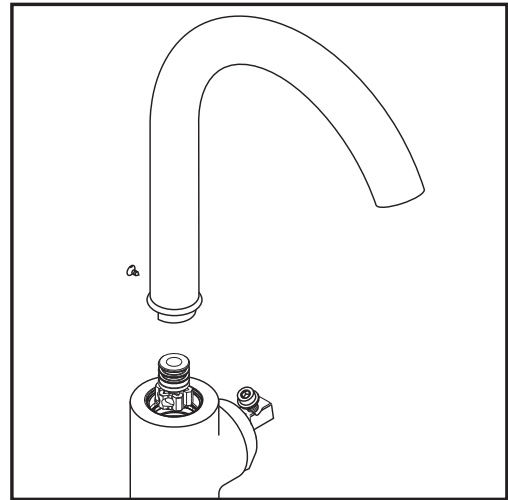

Place the faucet and sealing washer on the mounting surface.

If the mounting surface is less than 1 3/8", install the plastic washer, fiber washer, friction washer, and mounting nut.

If the mounting surface is greater than 1 3/8", omit the plastic washer.

Tighten the mounting nut. Tighten the tensioning screws.

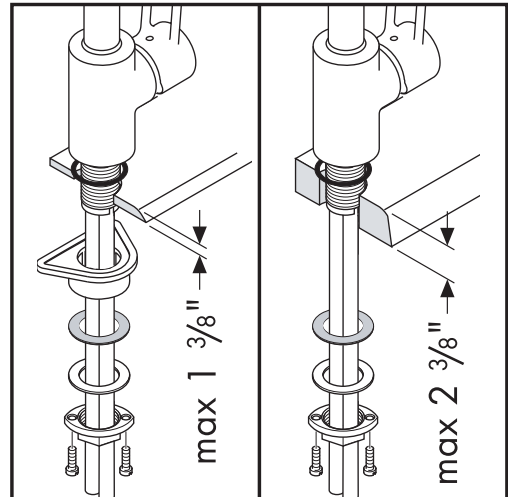

Install the hot and cold supply lines to the stops with 3/8" compression fittings (included).

Use two wrenches, as shown, to prevent the supply hoses from twisting.



Do not allow either hose to twist.



Twisting the supply hose may cause it to loosen from the faucet, which may cause water damage.

For proper operation of the faucet, the hot supply should be on the left, and the cold supply should be on the right.

Turn on the water and check all connections for leaks.

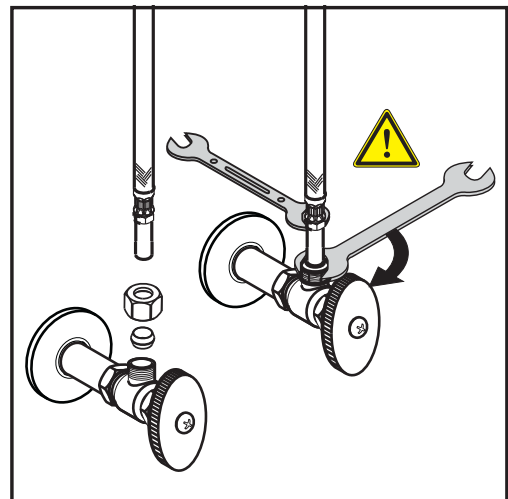

English

Install the handle

Install the handle screw on the cartridge stem.
Tighten only 4 turns.

Place the handle over the stem and handle screw.
Press it firmly into place.

Use a 4 mm Allen wrench to finish tightening the screw.

Install the screw cover.

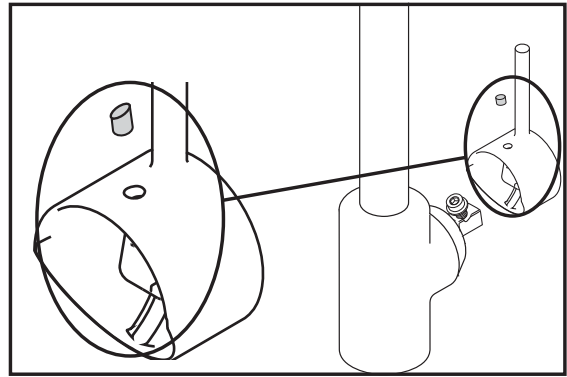

User Instructions

Push the handle to the right to turn the water on. Push it back to the left to turn the water off.
Swivel the handle forward for cooler water, backward for warmer water.

If the flow of water diminishes, remove and clean the aerator.

Faucet "Lay Down" Function

To provide clearance for opening a window, or for ease of cleaning, the faucet can be laid down on the counter without uninstalling it. Pull up on the faucet body, then gently lay the faucet down on the countertop. Do not pull the faucet by the neck!

When replacing the faucet, make sure that the pin on the bottom of the faucet goes into the hole on the base. Push the faucet down firmly against the base.

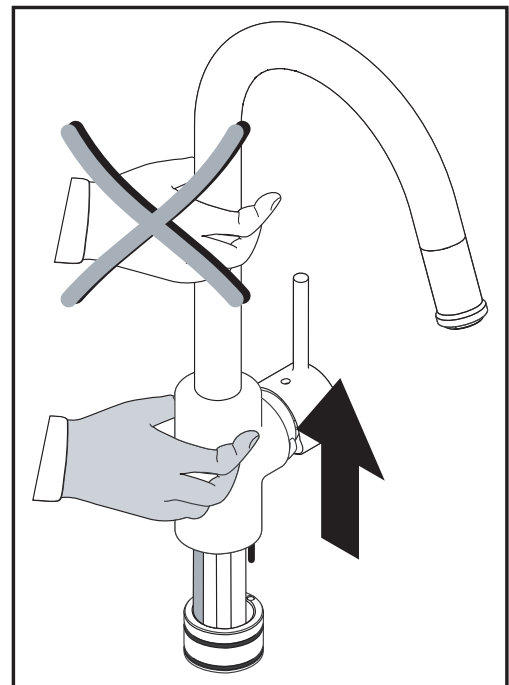
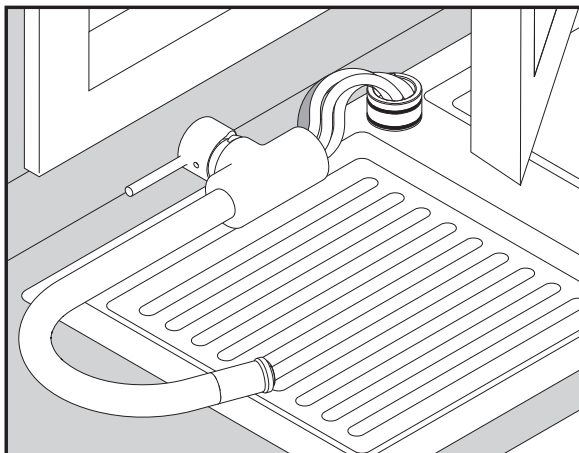

Allegro E Bar Faucet 14801XX1

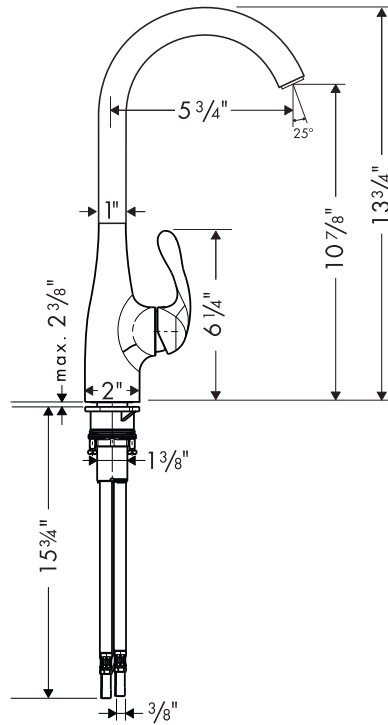

Technical Specification

Recommended water pressure	14.7 - 72.5 PSI
Recommended hot water temp.	120° - 140° F*
Hole size in mounting surface	1-1/2"
Max. mounting surface thickness	2 3/8"
Max. flow rate	1.5 GPM

*Please know and follow all applicable local codes when setting the temperature on the water heater.

Installation Considerations

- For best results, Hansgrohe recommends that this unit be installed by a licensed, professional plumber.
- Please read over these instructions thoroughly before beginning installation. Make sure that you have all tools and supplies needed to complete the installation.
- The hot and cold supply hoses connect to the stops with 3/8" compression fittings (included).
- Flush the hot and cold supplies thoroughly before installing this faucet. Debris in the water line may damage the ceramic cartridge.

14801XX1 Installation

Position the faucet and sealing ring on the mounting surface.

Install the fiber washer, metal washer, and mounting nut. Tighten the tensioning screws.

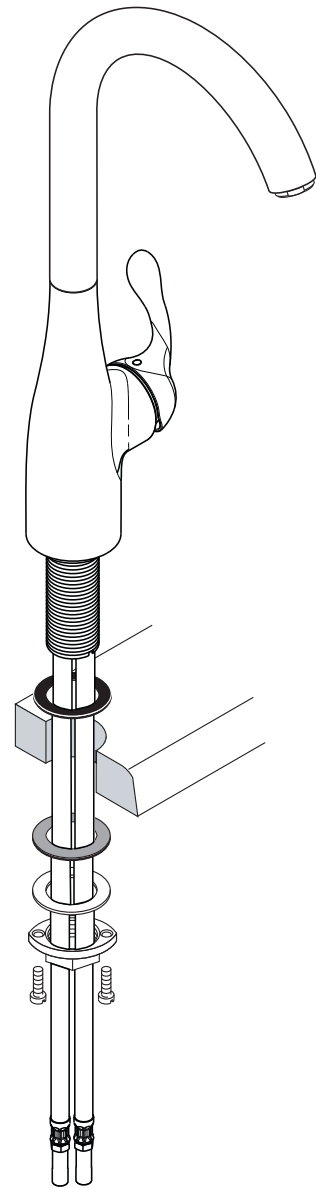

Install the hot and cold supply hoses on the stops with 3/8" compression fittings (included). Use two wrenches, as shown, to prevent the hoses from twisting and becoming loosened from the faucet.



Do not allow either hose to twist.



Twisting the supply hose may cause it to loosen from the faucet, which may cause water damage.

Turn on the water and check all connections for leaks.

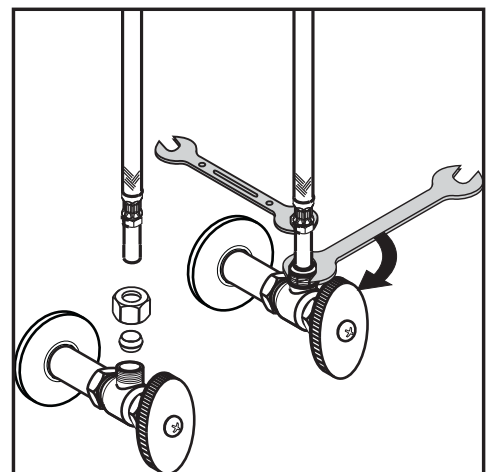

Robinet de bar HighArc
 06688XX0 Solaris E
 06696XX0 Stratos E
 06699XX0 Metro E
 06857XX0 Talis S

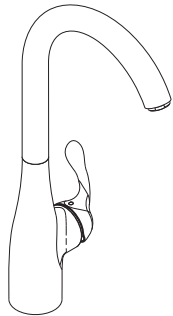

Allegro E 14801XX1
 voir p. 10

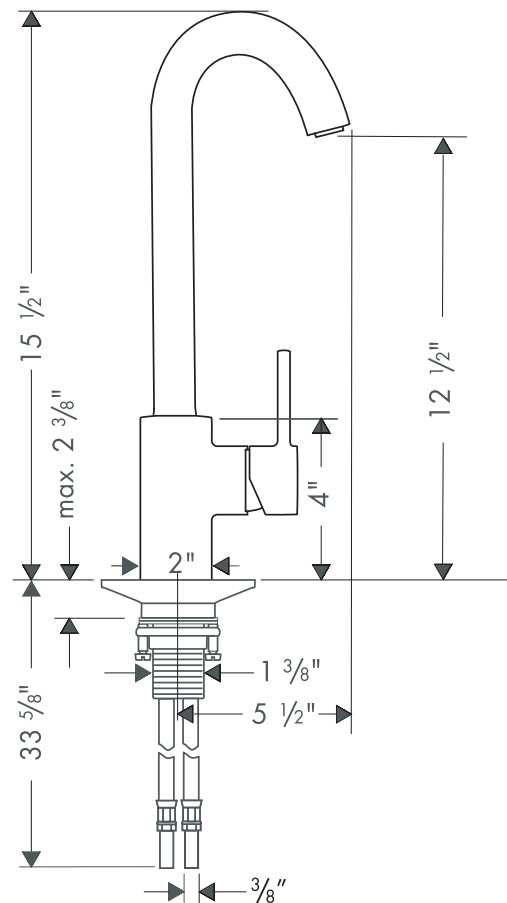

Données techniques

Pression d'eau recommandée	14,7 - 72,5 psi
Température recommandée pour l'eau chaude	120° – 140°F*
Dimension du trou dans la surface de montage	1-1/2 po
Profondeur maximale de la surface de montage	2 3/8 po
Débit	1,5 gpm max.
tuyaux d'arrivée de 3/8 po - requièrent des raccords à compression de 3/8 po (non compris)	

* Vous devez connaître et respecter tous les codes de plomberie locaux applicables pour le réglage de la température du chauffe-eau.

À prendre en considération pour l'installation

- Pour de meilleurs résultats, Hansgrohe recommande que ce produit soit installé par un plombier professionnel licencié.
- Veuillez lire attentivement ces instructions avant de procéder à l'installation. **Assurez-vous** de disposer de tous les outils et du matériel nécessaires pour l'installation.
- Les tuyaux d'arrivée d'eau chaude et d'eau froide requièrent des raccords à compression de 3/8 po (compris).

Installation du robinet

Enclenchez le bec en col de cygne sur le corps du robinet.

Serrez la vis.

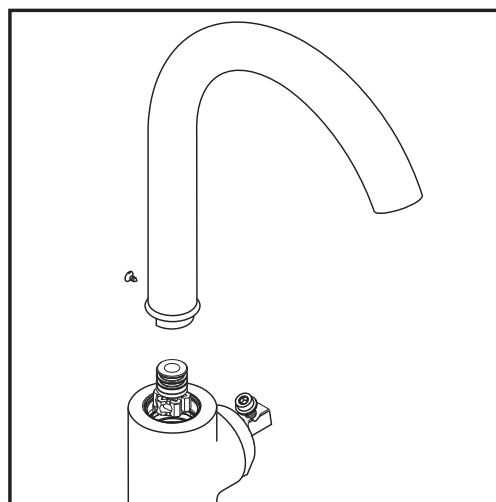

Placez l'anneau d'étanchéité et le robinet sur la surface de montage.

Installez la rondelle de plastique, la rondelle en fibre, la rondelle de friction et l'écrou de montage.

Si l'épaisseur du comptoir dépasse 1 3/8 po (3,5 cm) ou si l'espace disponible est insuffisant, omettez la rondelle de plastique.

Serrez l'écrou de montage et les vis de serrage.

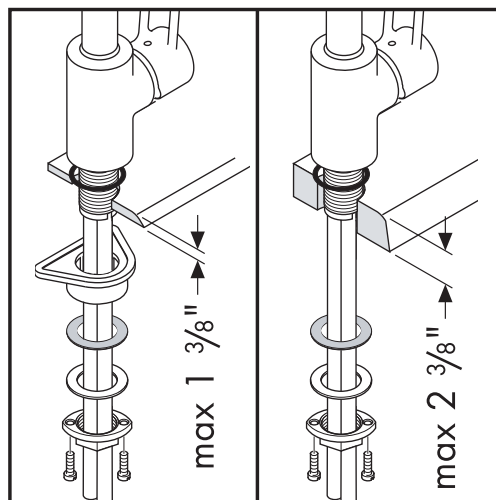

Connectez les tuyaux d'arrivée d'eau chaude et d'eau froide aux tuyaux d'alimentation à l'aide de raccords à compression de 3/8 po (9,5 mm) (non compris).

Assurez-vous que les tuyaux ne s'entortillent pas. Servez-vous de deux clés, tel qu'illustré dans le schéma. Serrez fermement à l'aide des clés.



Assurez-vous qu'aucun des tuyaux n'est entortillé.



Un tuyau tordu d'arrivée d'eau peut devenir détaché du robinet, qui causera une fuite.

Ouvrez l'eau. Vérifiez l'étanchéité de tous les raccords.

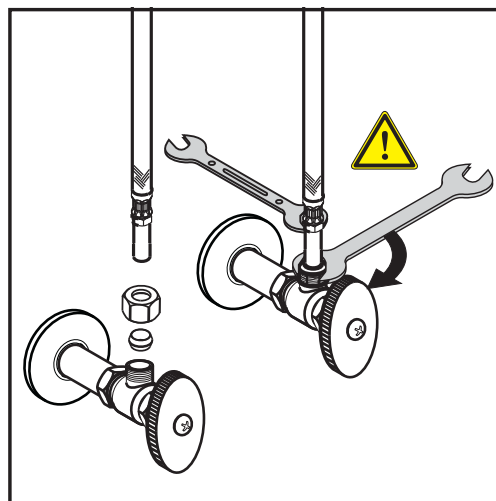

Installation de la poignée

Installez la vis de la poignée sur la tige. Serrez 4 tours complets.

Placez la poignée sur la tige et vissez la poignée. Appuyez bien fermement sur la poignée pour la fixer en place.

Utilisez une clé hexagonale de 4 mm pour finir de serrer la vis.

Installez le cache-vis.

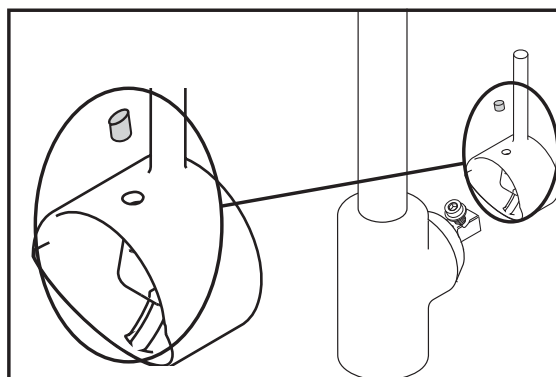

Instructions à l'intention de l'utilisateur

Le bec pivote complètement à 360°.

Poussez la poignée vers la droite pour ouvrir l'eau. Repoussez-la vers la gauche pour fermer l'eau. Faites pivoter la poignée vers l'avant pour obtenir de l'eau plus froide et vers l'arrière pour de l'eau plus chaude.

Si le débit d'eau diminue, retirez le aérateur et nettoyez-le.

Fonction commodité « Lay Down » du robinet

Si vous avez besoin d'espace supplémentaire pour ouvrir une fenêtre ou encore pour nettoyer, vous pouvez déposer le robinet sur le comptoir sans avoir à le désinstaller. Tirez sur le corps du robinet et déposez délicatement le robinet sur le comptoir. Ne tirez pas sur le robinet par le bec!

Lorsque vous remettez le robinet en place, assurez-vous que la tige du bas du robinet s'insère dans l'orifice de la base. Poussez fermement le robinet vers le bas, sur la base.

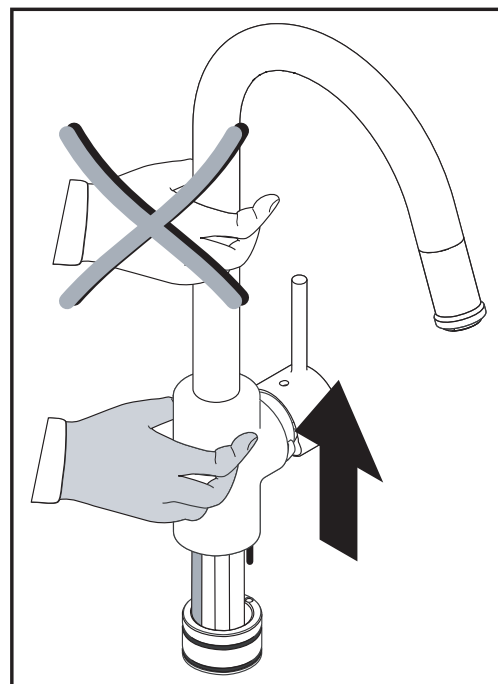
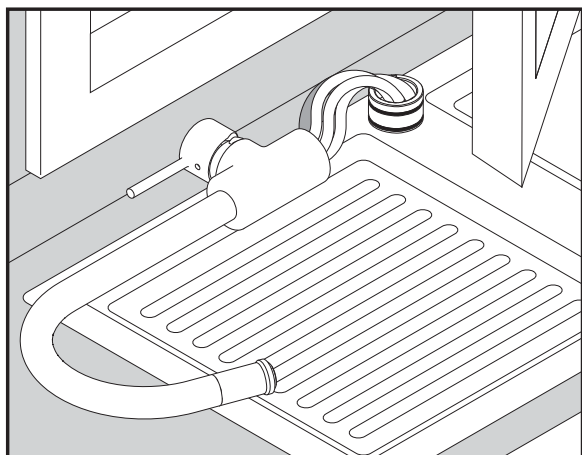

Allegro E Robinet de Bar 14801XX1

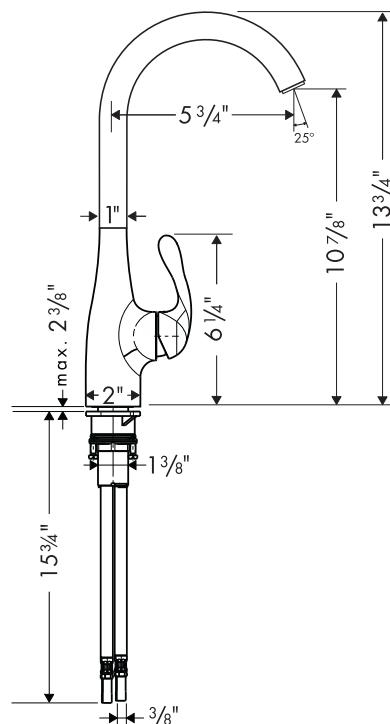

Données techniques

Pression d'eau recommandée	14,7 - 72,5 psi
Température recommandée pour l'eau chaude	120° – 140°F*
Dimension du trou dans la surface de montage	1-1/2 po
Profondeur maximale de la surface de montage	2 3/8 po
Débit	1,5 gpm max.

* Vous devez connaître et respecter tous les codes de plomberie locaux applicables pour le réglage de la température du chauffe-eau.

À prendre en considération pour l'installation

- Pour de meilleurs résultats, Hansgrohe recommande que ce produit soit installé par un plombier professionnel licencié.
- Veuillez lire attentivement ces instructions avant de procéder à l'installation. Assurez-vous de disposer de tous les outils et du matériel nécessaires pour l'installation.
- Les tuyaux d'arrivée d'eau chaude et d'eau froide requièrent des raccords à compression de 3/8 po (compris).

Installation du robinet 14801XX1

Placez l'anneau d'étanchéité et le robinet sur la surface de montage.

Installez la rondelle en fibre, la rondelle de friction et l'écrou de montage.

Serrez l'écrou de montage et les vis de serrage.

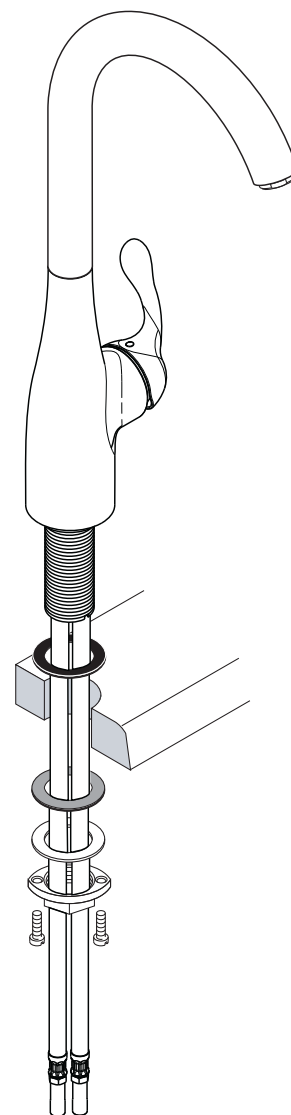

Connectez les tuyaux d'arrivée d'eau chaude et d'eau froide aux tuyaux d'alimentation à l'aide de raccords à compression de 3/8 po (9,5 mm) (compris).

Servez-vous de deux clés, tel qu'illustré dans le schéma. Serrez fermement à l'aide des clés.



Assurez-vous qu'aucun des tuyaux n'est entortillé.



Un tuyau tordu d'arrivée d'eau peut devenir détaché du robinet, qui causera une fuite.

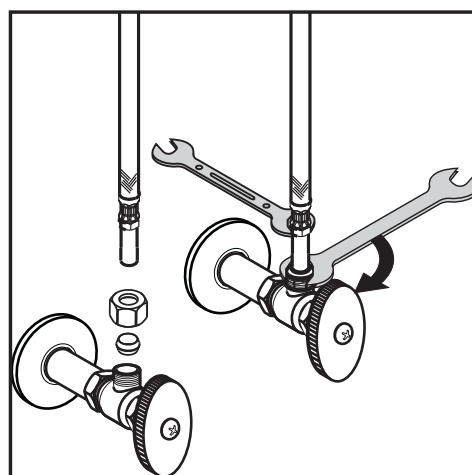

Ouvrez l'eau. Vérifiez l'étanchéité de tous les raccords.

Replacement Parts

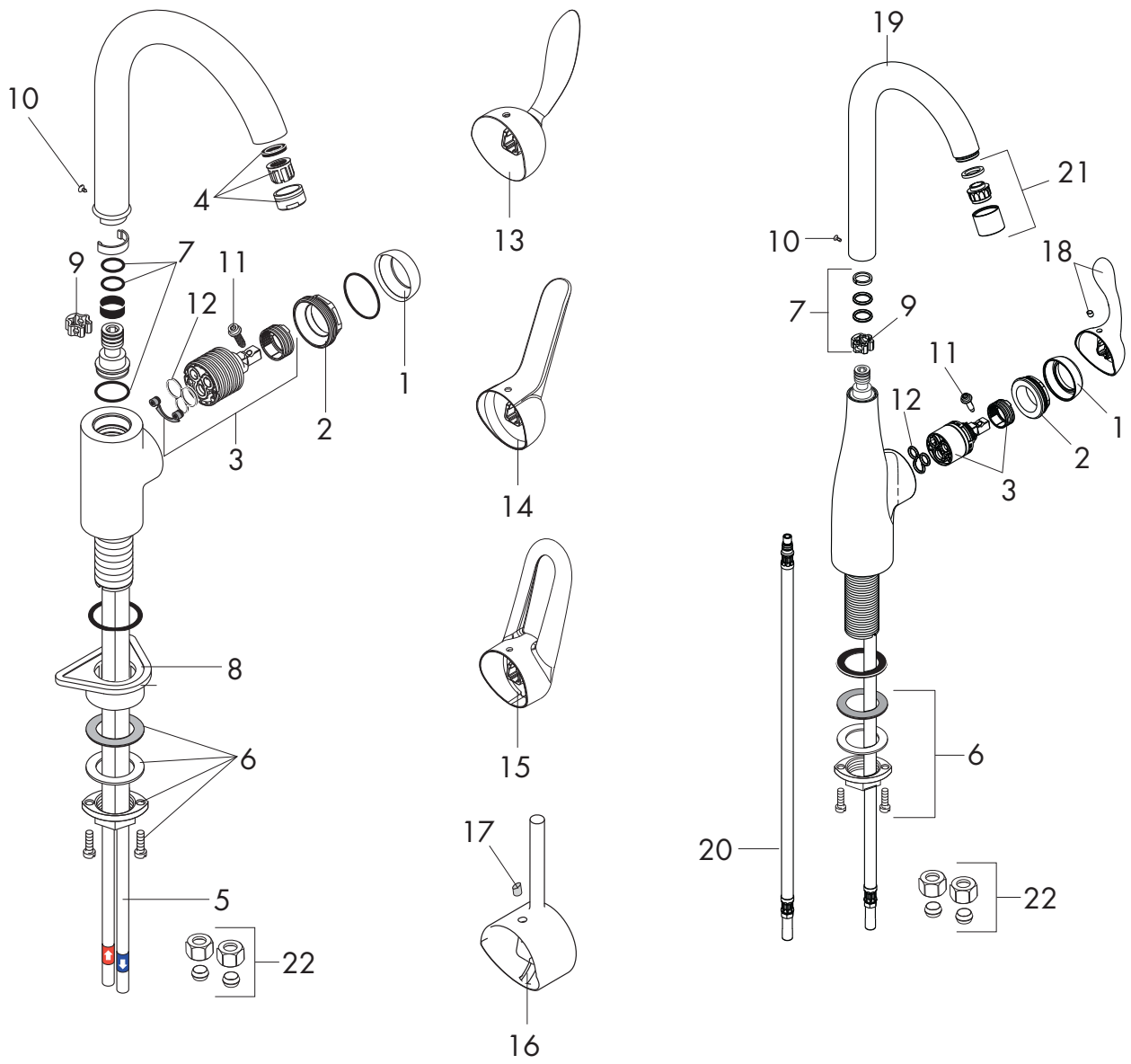

1	flange	96468XX0	17	screw cover	96338000
2	nut	96461000	18	handle, Allegro E	98597XX1
3	cartridge	92730000	19	spout	96521XX0
4	aerator	13185XX0	20	connection hose	98600001
5	connection hose	96316001	21	aerator	94010XX0
6	fixing set	95049000	22	3/8" compression fittings (pr.)	88513000
7	sealing set	92646000			
8	plastic washer	97523000			
9	axial ring	97558000			
10	screw	97662000			
11	handle screw	96059000			
12	seal	95008000			
13	handle, Solaris	06981XX0			
14	handle, Stratos	06983XX0			
15	handle, Metro	06984XX0			
16	handle, Talis S	06985XX0			

XX = color
 00 = Chrome
 86 = Steel Optik

Cleaning Recommendation for Hansgrohe Products

Modern lavatory faucets, kitchen faucets, and showers consist of very different materials to comply with the needs of the market with regard to design and functionality. To avoid damage and returns, it is necessary to consider certain criteria when cleaning.

Cleaning Materials for Faucets and Showers

Acids are a necessary ingredient of cleaning materials for removing lime, however please pay attention to the following points when cleaning faucets and showers:

- Only use cleaning materials which are explicitly intended for this type of application.
- Never use cleaning materials which contain hydrochloric, formic, phosphoric, or acetic acid, as they cause considerable damage.
- Never mix one cleaning material with another.
- Never use cleaning materials or appliances with an abrasive effect, such as unsuitable cleaning powders, sponge pads, or micro fiber cloths.

Cleaning Instructions for Faucets and Showers

Please follow the cleaning material manufacturer's instructions. In addition, pay attention to the following points:

- Clean the faucets and showers as and when required
- Use the amount of cleaning product and the amount of time recommended by the manufacturer. Do not leave the cleaner on the fixture longer than necessary.
- Regular cleaning can prevent calcification.
- When using spray cleaners, spray first onto a soft cloth or sponge. Never spray directly onto the faucet as droplets can enter openings and gaps and cause damage.
- After cleaning, rinse thoroughly with clean water to remove any cleaner residue.

Important

Residues of liquid soaps, shampoos, and shower foams can also cause damage, so rinse with clean water after using.

Please note: if the surface is already damaged, the effect of cleaning materials will cause further damage.

Components with damaged surfaces must be replaced or injury could result.

Damage caused by improper treatment is not covered under the warranty.

Recommandations pour le nettoyage des produits Hansgrohe

Les robinetteries modernes de lavabo, de cuisine et de douche utilisent des matériaux très différents pour répondre aux besoins du marché en termes de conception et de fonctionnalité. **Certaines règles de base doivent être respectées lors du nettoyage de ces produits afin d'éviter de les endommager ou d'avoir à les retourner.**

Produits de nettoyage pour robinetteries et douches

Les acides sont une partie intégrante nécessaire de tous les produits de détartrage; il faut cependant prendre les précautions suivantes lors du nettoyage des robinets et des douches :

- N'utilisez que des produits/articles de nettoyage conçus spécifiquement pour les articles de robinetterie et de douche.
- N'utilisez jamais de produits/articles de nettoyage contenant de l'acide chlorhydrique, formique, phosphorique ou acétique car ils pourraient causer des dommages considérables.
- Ne mélangez jamais deux produits de nettoyage.
- N'utilisez jamais de produits/articles de nettoyage de nature abrasive tels que poudres de nettoyage, tampons-éponge ou chiffons microfibre non appropriés.

Instructions de nettoyage pour robinetteries et douches

Veillez suivre les instructions du fabricant de produits/articles de nettoyage. **De plus, tenez compte des conseils suivants :**

Nettoyez vos produits de robinetterie et de douche aussi souvent que nécessaire.

- Utilisez la quantité de produit nettoyant et respectez la durée recommandée par le fabricant. **Ne laissez pas le produit sur les articles de robinetterie plus longtemps que nécessaire.**
- Un nettoyage régulier peut prévenir la formation de dépôts calcaires.
- Si vous utilisez des nettoyants en vaporisateur, vaporisez d'abord sur une éponge ou un chiffon. **Ne vaporisez jamais directement sur un robinet :** des gouttelettes pourraient s'infiltrer dans les ouvertures et les interstices et endommager celui-ci.
- Après le nettoyage, rincez abondamment avec de l'eau propre pour éliminer tout résidu de produit nettoyant.

Important

Les résidus de savon liquide, de shampoing et de mousse pour la douche peuvent également endommager la robinetterie; rincez donc avec de l'eau propre après utilisation de ces produits.

Veillez noter : si la surface est déjà endommagée, les produits de nettoyage l'endommageront encore plus.

Les composants dont la surface est endommagée devraient être remplacés sous peine d'entraîner des blessures.

Les dommages dus à un mauvais traitement ne sont pas couverts par la garantie.

Limited Lifetime Consumer Warranty

This product has been manufactured and tested to the highest quality standards by Hansgrohe, Inc. ("Hansgrohe"). This warranty is limited to Hansgrohe products which are purchased by a consumer in the United States after March 1, 1996, and installed in either the United States or Canada.

WHO IS COVERED BY THE WARRANTY

This warranty extends to the original consumer purchaser only. This warranty is non-transferable.

WHAT IS COVERED BY THE WARRANTY

This warranty covers only your Hansgrohe manufactured product. Hansgrohe warrants this product against defects in material or workmanship as follows: Hansgrohe will repair at no charge for parts only or, at its option, replace any product or part of the product that proves defective because of improper workmanship and/or material, under normal installation, use, service and maintenance. If Hansgrohe is unable to provide a replacement and repair is not practical or cannot be timely made, Hansgrohe may elect to refund the purchase price in exchange for the return of the product.

LENGTH OF WARRANTY

Replacement or repaired parts of products will be covered for the term of this warranty as stated in the following two sentences. If you are a consumer who purchased the product for use primarily for personal, family, or household purposes, this warranty extends for as long as you own the product and the home in which the product is originally installed. If you purchased the product for use primarily for any other purpose, including, without limitation, a commercial purpose, this warranty extends only (i) for 1 year, with respect to Hansgrohe and Commercial products, and (ii) for 5 years, with respect to AXOR products.

THIS WARRANTY DOES NOT COVER, AND HANSGROHE WILL NOT PAY FOR:

- A. Conditions, malfunctions or damage not resulting from defects in material or workmanship.
- B. Conditions, malfunctions or damage resulting from (1) normal wear and tear, improper installation, improper maintenance, misuse, abuse, negligence, accident or alteration, or (2) the use of abrasive or caustic cleaning agents or "no-rinse" cleaning products, or the use of the product in any manner contrary to the product instructions. (3) Conditions in the home such as excessive water pressure or corrosion.

- C. Labor or other expenses for the disconnection, deinstallation, or return of the product for warranty service, or for installation or reinstallation of the product (including but not limited to proper packaging and shipping costs), or for installation or reinstallation of the product.
- D. Accessories, connected materials and products, or related products not manufactured by Hansgrohe.

TO OBTAIN WARRANTY PARTS OR INFORMATION

Contact your Hansgrohe retailer, or contact Technical Service at:

Hansgrohe Inc.
1492 Bluegrass Lakes Parkway
Alpharetta GA 30004
Toll-free (800) 334-0455.

In requesting warranty service, you will need to provide

1. The sales receipt or other evidence of the date and place of purchase.
2. A description of the problem.
3. Delivery of the product or the defective part, postage prepaid and carefully packed and insured, to Hansgrohe Inc. 1492 Bluegrass Lakes Parkway, Alpharetta, Georgia 30004, Attention: Technical Service, if required by Hansgrohe.

When warranty service is completed, any repaired or replacement product or part will be returned to you postage prepaid.

EXCLUSIONS AND LIMITATIONS

REPAIR OR REPLACEMENT (OR, IN LIMITED CIRCUMSTANCES, REFUND OF THE PURCHASE PRICE) AS PROVIDED UNDER THIS WARRANTY IS THE EXCLUSIVE REMEDY OF THE PURCHASER. HANSGROHE NEITHER ASSUMES NOR AUTHORIZES ANY PERSON TO CREATE FOR IT ANY OBLIGATION OR LIABILITY IN CONNECTION WITH THIS PRODUCT.

HANSGROHE SHALL NOT BE LIABLE TO PURCHASER OR ANY PERSON FOR ANY INCIDENTAL, SPECIAL, OR CONSEQUENTIAL DAMAGES, ARISING OUT OF BREACH OF THIS WARRANTY OR ANY IMPLIED WARRANTY (INCLUDING MERCHANTABILITY).

Some States do not allow the exclusion or limitation of incidental or consequential damages, so the above limitation or exclusion may not apply to you. This warranty gives you specific legal rights, and you may have other rights which vary from State to State. You may be required by law to give us a reasonable opportunity to correct or cure any failure to comply before you can bring any action in court against us under the Magnuson-Moss Warranty Act.

PRODUCT INSTRUCTIONS AND QUESTIONS

Upon purchase or prior to installation, please carefully inspect your Hansgrohe product for any damage or visible defect. Prior to installing, always carefully study the enclosed instructions on the proper installation and the care and maintenance of the product. If you have questions at any time about the use, installation, or performance of your Hansgrohe product, or this warranty, please call or write to us or call us toll-free at 800 334 0455.

hansgrohe

Hansgrohe, Inc. • 1490 Bluegrass Lakes Parkway • Alpharetta, GA 30004
Tel. 770-360-9880 • Fax 770-360-9887

www.hansgrohe-usa.com