

Futura Series

Pre-Finished Dishwashers

CLASSIC PLUS	G 4925 U, G 4925 SCU
CRYSTAL	G 6105 U, G 6105 SCU
DIMENSION	G 6305 SCU



SPECIFICATIONS	
Overall Unit Width	23 ⁹ / ₁₆ " (598mm)
Overall Unit Height	33 ¹¹ / ₁₆ " - 36 ¹ / ₄ " (855 - 920mm)
Overall Unit Depth	22 ⁷ / ₁₆ " (570mm)
Niche	
Minimum Cabinet Opening Width	23 ⁵ / ₈ " (600mm)
Minimum Cabinet Opening Height	33 ³ / ₄ " (857mm)
Minimum Cabinet Opening Depth	22 ⁷ / ₁₆ " (570mm)
Plumbing	
Water Supply Requirements	May be connected to a cold or hot water supply up to a maximum of 140°F/60°C. Must be connected to a shut-off valve with a male 3/8" NPT. The water shut-off valve must be accessible after installation. The water pressure must be between 4.35 psi (0.3 bar) and may not exceed 145 psi (10 bar). If the pressure is higher than 145 psi (10 bar), a pressure reducing valve must be installed.
Water Connection Line	4' 11" (1.5m) flexible water intake hose is supplied with a 3/8 NPT connection.
Drain Hose	4' 11" (1.5m) flexible drain hose is supplied.
Electrical	
Electrical Requirements - Volts/Amps	110V / 120V, 60Hz, 15 Amps
Power Cord - Plug and length	Yes - NEMA 5-15 plug, 5' 6" (1.7m), Convertible to Hardwire
Shipping	
Shipping Weight	118 lbs (53.5 kg)
Support	
Call Miele	800.843.7231
Miele Website	www.mieleusa.com
20/20 Link	2020technologies.com

INSTALLATION SPECIFICATIONS

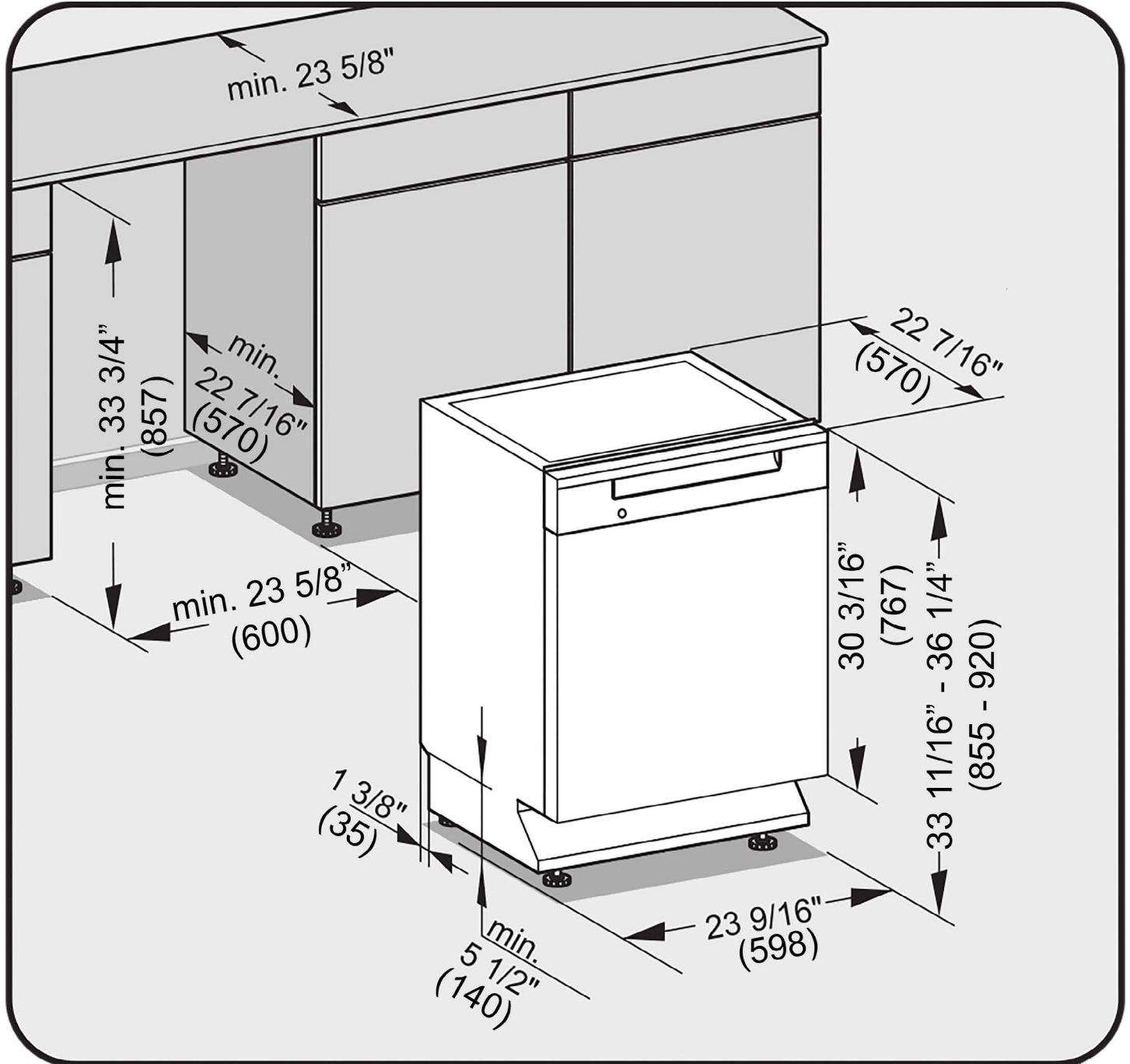

Futura Series

Pre-Finished Dishwashers



Panel Specification

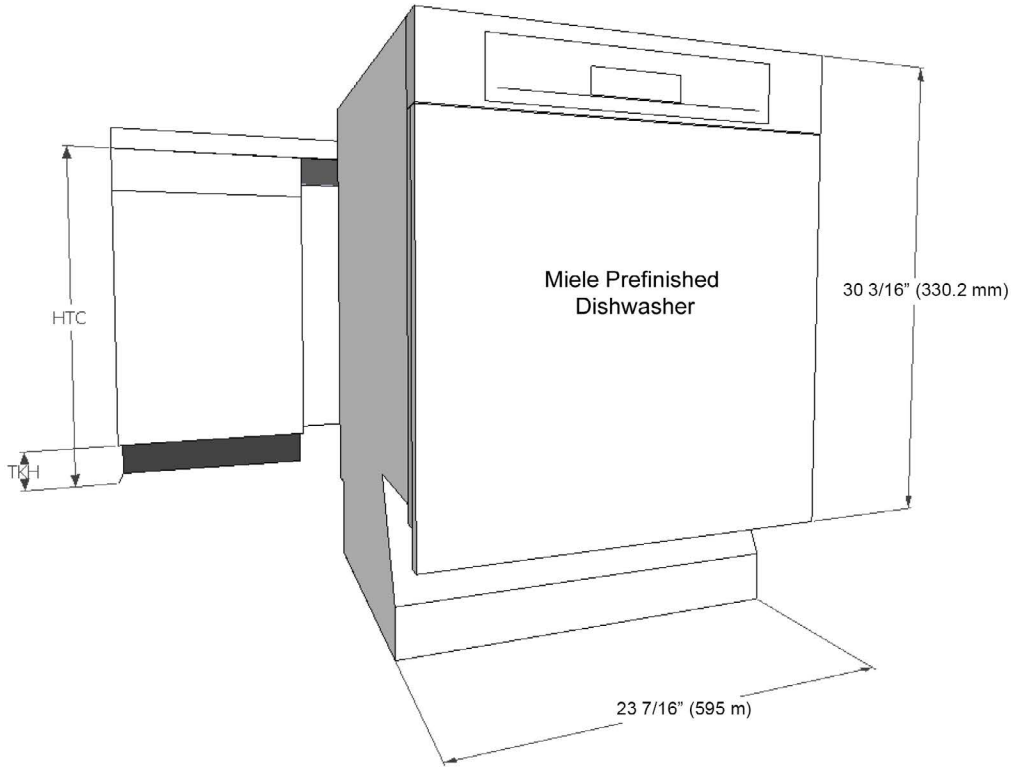

Panel and Control Prefinished

Width: $23 \frac{7}{16}''$ (595 mm)

Thickness: $\frac{3}{4}''$ (19 mm)

Height: $30 \frac{3}{16}''$ (767 mm)

Calculating the toe kick height:

$$30 \frac{3}{16}'' - \text{HTC} = \text{TKH}$$

HTC = Height to underside of countertop

TKH = Toe kick height

Futura Series
Pre-Finished Dishwashers



		Height to underside of countertop									
		33 3/4	34	34 1/4	34 1/2	34 3/4	35	35 1/4	35 1/2	35 3/4	36
Toe Kick Height	2 1/2	Acceptable combinations									
	3	Acceptable combinations									
	3 1/2	Acceptable combinations									
	4	Acceptable combinations									
	4 1/2	Acceptable combinations									
	5	Acceptable combinations									
	5 1/2	Acceptable combinations									
	6	Acceptable combinations									
	6 1/2	Acceptable combinations									
	7	Acceptable combinations									
	7 1/2	Acceptable combinations									
	8	Acceptable combinations									
	8 1/2	Acceptable combinations									
		Acceptable combinations			Typical American installation						