

BELLA ISOLA ISLAND RANGE HOOD



A BEAUTIFUL NEW ISLAND CANOPY WITH ADVANCED FEATURES. The new Bella Isola features a fully welded body in a euro-style box shape with stainless covered mesh filters. The control features 8 round buttons with a white LED indicator screen. With an auto shut off timer, 2 level LED lights, 24 hour anti-pollution mode and a filter wash reminder - the Bella Isola has all the features you need.



Note: picture does not reflect correct filters

AVAILABLE MODELS

Model #	Size / Color	Motor Class (CFM)	Sound Levels (sones)
BELAIS36SS600-B	36 Stainless	600 CFM	2.8 - 7.5 sones
BELAIS42SS600-B	42 Stainless	600 CFM	2.8 - 7.5 sones

KEY FEATURES



Electronic controls

Electronic controls with a white LED indicator to show the current speed and two level lighting, 24 hour anti-pollution mode and filter wash indicator



Remote Control (optional)

Control all features of the hood from the convenience of a wireless remote control (sold separately)



Pro Motor

The motor in this hood is surrounded in metal with all metal impellers for top performance



24 Hour Anti-Pollution Mode

This mode runs the hood for 10 minutes once an hour at a low cfm to refresh the air in your home

BELLA ISOLA ISLAND RANGE HOOD



SPECIFICATIONS

min / max ceiling height	7' 6 1/8" - 8' 10 15/16"
convertible to ductless / recirculating	yes - kit sold separately
canopy depth / height	26 5/8" d / 2 3/8" h
high ceiling kit	yes - reaches up to 10' 10" ceilings
controls	8 buttons with led read out screen
lighting	4 x 1 (w) LED - two level
ducting top	6" round
grease filters	dishwasher safe stainless mesh
24 hour anti-pollution mode	yes
Pro Motor (metal impellers)	yes
6 minute intensive speed	yes
30 minute auto shut off	yes
filter wash indicator	yes
ADA compliant	yes (with remote control purchase)
power cord included	yes
AC power	400 watts / 3.2 amps

PERFORMANCE

SPEED	1	2	3	BOOST
CFM	150	300	450	560
Sones	2.8	4.3	6.0	7.5

DIMENSIONS

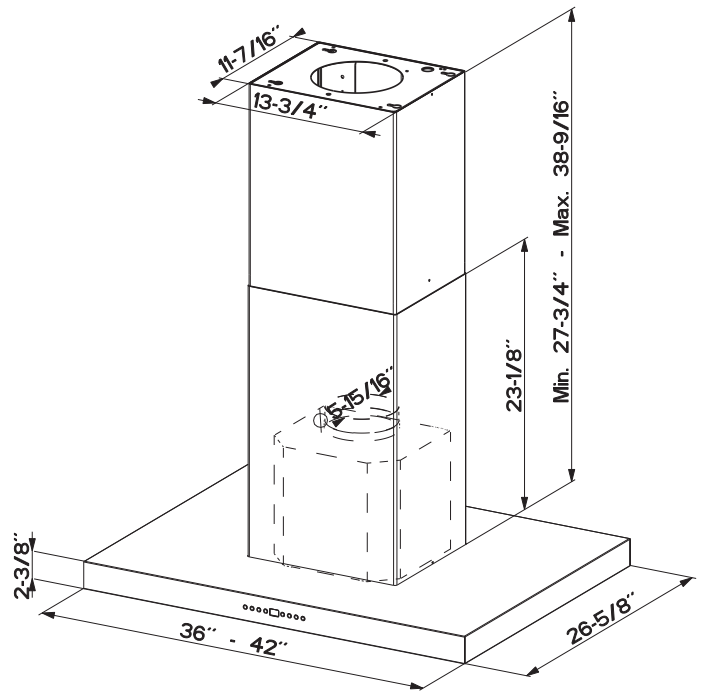

ACCESSORIES

FILTER2 -

Charcoal Filter Kit

High quality charcoal filter for use when recirculating the air back into the kitchen. Filters out odor and should be replaced every 6 months

HIGH2 -

High Ceiling Kit

High ceiling kit replaces the upper chimney with taller chimney to reach up to 10' 10"

DUCT2 -

Ductless Conversion Kit

To convert the Bella Isola to ductless, this kit includes charcoal filters and a diverter to send the air thru the side grates on the upper chimney.

CFMRED -

CFM Reducer Kit

For use in make up air areas where an under 300 cfm hood is required. This kit reduces the ducting to 5" round and reduces the cfm to under 300

REMCTRL -

Remote Control

Control all features of the hood from the convenience of a wireless remote control

MUDAMPER6 / MUDAMPER8 -

Universal Make-Up Air Damper

Satisfies make-up air requirements, this kit uses an air switch to activate the make-up air damper to open and bring fresh air into the home when the hood fan is on. It then closes tightly when the hood is off. The CFM level is not reduced with this accessory.



WARNING! Product specifications are subject to change without notification. Consult the installation instructions before you begin installing this range hood



Imagined in Italy