

FULGOR

MILANO

700 Series 30" Self Cleaning Single Wall Oven

F7SP30W1



Series	700
Type	PYRO
Size	30"x30"
Colour	WHITE
Stainless Steel Aesthetics	Embossed window profile with bended edges
Oven Type	Multifunction 2 Fans (True Euro Convection)
Temperature Regulation	Full Electronic

Key	Functions		
LIGHT	LIGHT		•
DEHIDR	DEFROST		•
	DEHYDRATE		•
KEEP WARM	WARM		•
	WARM +		•
BAKE	BAKE		•
	ROAST		•
	TRUE CONVECTION BAKE		•
CONV.	CONVECTION ROAST		•
	CONVECTION BAKE		•
	CONVECTION GRILL		•
PIZZA	CONVECTION BROIL		•
	PIZZA		•
BROIL	BROIL LEVELS		•
SELF C.	SELF CLEAN		•

Control Panel	
Control type	MODULAR - Electronic
Display	TFT 3,5"
Menu Recipes	•
Commands	Full Touch
Language	11

Special Features	
Demo Mode	•
Brightness setting (ON condition)	•
Brightness setting (OFF condition)	•
Beeper volume setting	•
Date format	•
Automatic Fast Preheat	•
Classic PIZZA function 310°C	•
Child Door Lock	•

FULGOR

MILANO

Commands Lock	•
Sabbath mode	•
12/24 hours clock format	•
°C/°F degree unit	•
Door miscro switch	•
Event logs (for Service)	•
Oven Door(s)	
Oven Glass Window	Large See Through Glass
Door Cooling System	4 Pane Heat Resistant Glass
Door Hinges	Heavy Duty Steady Tilt
Oven Cavity	
Gross Capacity (cbft)	4.4
Net Capacity (cbft)	4.1
Cavity Enameling Colour	Black
Rack Positions	6
Oven Lights	3 or 2 x 20W Halogen
Broil Upper Heating Element	3500 W (240V)
Upper Auxiliary Element Wattage	1032W (240V)
Concealed Bake Lower Heating Element	3000 W (240V)
Convection Element Wattage	2x1300W (240V)
Oven Accessories	
Chromed racks	•
Enameled Grill set (basin + anti splash)	•
Telescopic chromed rack	•
Meat probe	•
Dimensions/Weight - (In or Lbs)	
Overall dim - width	29 11/16" (754mm)
Overall dim - height	27-7/8" (707mm)
Overall dim - depth	24" (610mm)
Cutout - width	28 7/16" (722mm)
Cutout - height (min)	27-1/4" (692mm)
Cutout - depth (min)	23-1/4" (590mm)
Power / Ratings (208/240 V, 60 Hz)	
KW/Amps rating at 240V, 60Hz	3.70kW - 15.4A
KW/Amps rating at 208V, 60Hz	3.50kW - 16.8A
Cable + Conduit	•
INSTRUCTIONS FOR USE	
Use & Care Manual	EN, SP, FR
Installation Manual	EN, SP, FR

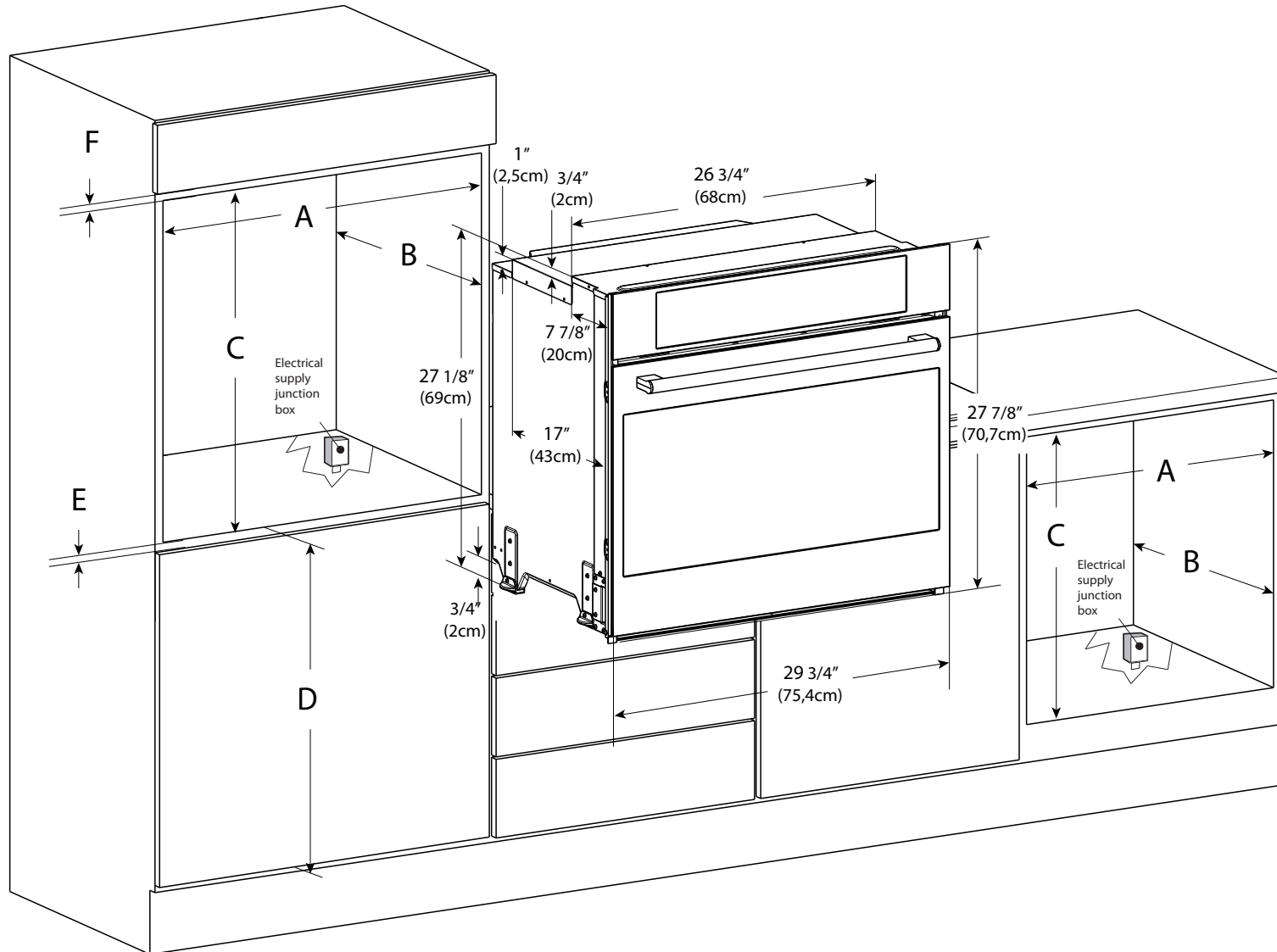

Ltr.	CUTOUT DIMENSION	inch	cm
A	Cutout Width	28 7/16"	72,2cm
B	Cutout Depth	24"	61cm
C	Cutout Height	27 3/8"	69,5cm
D	Floor Bottom of Cutout	34"	86,5cm
E	Minimum Spacing	1/2"	1,3cm
F	Minimum Spacing	3/4"	1,9cm

PACKAGING		lb / inch	Kg / mm
GROSS WEIGHT		181 lb	82 Kg
DIMENSION	W	33"1/2	850
	D	30"5/1	770
	H	31"1/8	790

