

Front Load Washers & Dryers

Featuring Wave-Touch™ Electronic Controls



amazing performance

The Electrolux laundry collection has all the latest features and beautiful style. With Electrolux, doing the laundry is faster, better and easier.

Front Load Washers:

Wave-Touch™ Controls –
EWFLW65H TS/SS/IW

Front Load Dryers:

Perfect Steam™ /Wave-Touch™ Controls –
EWMED65H TS/SS/IW (Electric)
EWMGD65H TS/SS/IW (Gas)

Wave-Touch™ Controls –
EWED65H TS/SS/IW (Electric)
EWGD65H TS/SS/IW (Gas)

Available in:



Turquoise Sky



Silver Sands



Island White

Electrolux

The New Collection from the premium kitchen appliance brand that has been used in Europe for over 70 years

features

Wave-Touch™ Controls

The Wave-Touch™ control panel offers the most wash and dry cycles/options,¹ including three “My Favorite” settings and a wash stain menu with 21 settings.

Largest Capacity Washers and Dryers²

Wash and dry the most in one load.

Fastest Wash and Dry Times³

18 minutes to wash, 18 minutes to dry — so your clothes are ready before you are.

front load washers

Perfect Balance™ System

State-of-the-art technology keeps even oversized wash loads balanced for smooth, quiet operation.

AquaLux™ Wash System

Energy-efficient wash system is gentle on the environment and on clothes.

Eco-Friendly

Gentle on the environment as they are on your clothes. Wave-Touch™ Control models are 83% more energy efficient⁴ and use 56% less water.⁵

front load dryers

Perfect Steam™ Dryer:

The latest technology steams out wrinkles and freshens clothes. (Select models only)

Perfect Tumble™

Exclusive technology offers the gentlest drying for clothes.⁶

Luxury-Dry™ System

Exceptional temperature control helps protect fabrics and keeps clothes looking great.

¹Based on manufacturer specifications.

²Based on manufacturer specifications.

³Fastest time based on smallest load/Fast Wash and Fast Dry cycles.

⁴Energy efficiency based on current DOE Federal Minimum standard for washers based on MEF.

⁵Water Savings based on DOE ENERGY STAR® energy savings calculator.

⁶Lowest cloth temperature on 8 lb. permanent press load.

Drop into our Virtual Laundry Room at electroluxappliances.com

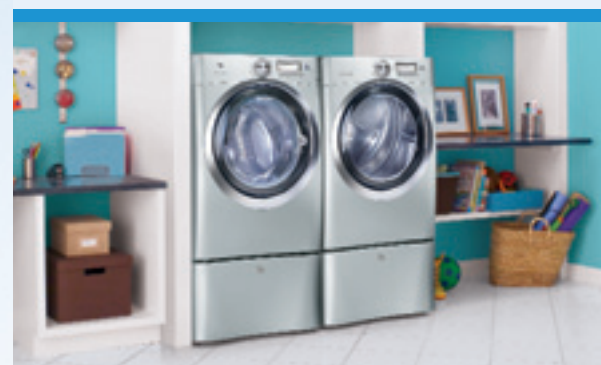



27" Front Load Washers
EWFLW65H TS/SS/IW

Features

ENERGY STAR®	Yes
NSF® Certified	Yes
Signature Soft-Arc Door Design	Yes
Wave-Touch™ Electronic Controls with LCD Display	Yes
Perfect Balance™ System	Yes
Luxury-Quiet™ Sound Package	Yes
Luxury-Design™ Lighting	Yes
Touch-2-Open™/(Close) Door	Yes
Luxury-Glide™ Touch-2-Open™/(Close) Dispenser Drawer	Yes
AquaLux™ Wash System	Yes
Integral Water Heater	Yes
Front Console Control Location	Yes
Stainless Steel Wash Drum	Yes
Automatic Water Level Adjustment	Yes
Auto Prewash Detergent Dispenser (Liquid/Powder)	Yes
Auto Bleach Dispenser (Liquid Only)	Yes
Auto Detergent Dispenser (Liquid/Powder)	Yes
Auto Fabric Softener Dispenser	Yes
Tumble Speed (RPM)	48-52 Variable
Spin Speed (RPM)	1,300
Reversible Door	Yes
Adjustable Leveling Legs	Yes

Cycles

Fast Wash, My Favorites (3), Deep Clean Sanitize, Heavy Duty, Whites, Colors, Normal, Active Wear, Casual, Delicates, Hand Wash, Spin Only	14
Individual Custom Options (3) – Additional user settings, each with 11 cycles and 3 My Favorites (14)	42
Total Cycles Available	56

Options

Wash/Rinse Temperature Combinations	9
Temperature Selections w/ Automatic Temperature Controls	6
Spin Speed Selections	6
Soil Level Selections	6
Delay Start (Hours)	22
End-of-Cycle Chime	Adjustable

Accessories

Luxury-Glide™ Touch-2-Open™/(Close) Pedestal – Turquoise Sky (EPWD15TS), Silver Sands (EPWD15SS), Island White (EPWD15IW)	Optional
Drain Hose Extension Kit – (137098000)	Optional
Mobile Home Installation Kit – (137067200)	Optional

Specifications

Power Supply/Water Inlet Location	Top Right Rear/ Top Left Rear
Voltage Rating	120V/60Hz/15A
Connected Load (kW Rating) @ 120 Volts†	1.4
Watts @ 120 Volts	1,000
Amps @ 120 Volts	12
Product Weight	237 Lbs.
Shipping Weight	247 Lbs.

†For use on adequately wired 120V, dedicated circuit having 2-wire service with a separate ground wire. Appliance must be grounded for safe operation. NOTE: Always consult local and/or national electric codes. Refer to Product Installation Guide for detailed installation instructions on the web at electroluxappliances.com. Specifications subject to change.



27" Front Load Dryers
*EWME/GD65H TS/SS/IW
EWE/GD65H TS/SS/IW

Features

NSF® Certified	Yes
Signature Soft-Arc Door Design	Yes
Wave-Touch™ Electronic Controls with LCD Display	Yes
Perfect Steam™ Dry System (EWME/GD65H)	Yes*
Perfect Tumble™ Dry System	Yes
Luxury-Quiet™ Sound Package	Yes
Luxury-Design™ Lighting	Yes
Luxury-Dry™ System	Yes
Touch-2-Open™/(Close) Door	Yes
Exact Dry™ Moisture Sensor	Yes
Front Console Control Location	Yes
Stainless Steel Dryer Drum	Yes
Tumble Speed (RPM)	50
Reversible Door	Yes
Adjustable Leveling Legs	Yes

Cycles

Fast Dry, My Favorites (3), Heavy Duty, Bulky/Bedding, Mixed Load, Towels, Normal, Active Wear, Casual, Delicate, Touch Up (EWE/GD65H), Perfect Steam™ (EWME/GD65H)*, Timed Dry	14
Individual Custom Options (3) – Additional user settings, each with 11 cycles and 3 My Favorites (14)	42
Total Cycles Available	56

Options

Temperature Selections	7
Electronic Auto Dry System	Yes
Manual Timed Dry Selections	6
End-of-Cycle Chime	Adjustable

Accessories

Luxury-Glide™ Touch-2-Open™/(Close) Pedestal – Turquoise Sky (EPWD15TS), Silver Sands (EPWD15SS), Island White (EPWD15IW)	Optional
Dryer Stacking Kit – (134700400)	Included
LP Conversion Kit (Gas Models) – (134709300)	Optional
Mobile Home Installation Kit – (137067200)	Optional
Drying Rack – (134912700)	Included

Electric Specifications

Power Supply Connection Location	Bottom Right Rear
Voltage Rating	240V/60Hz/30A
Connected Load (kW Rating) @ 240 Volts	6.48
Amps @ 240 Volts	27
Heating Element @ 240 Volts (Watts)	5500
Product Weight	130 Lbs.
Shipping Weight	140 Lbs.

Gas Specifications

Gas/Power Supply Connection Location	Bottom Center Rear Bottom Right Rear
Voltage Rating	120V/60Hz/15A
Connected Load (kW Rating) @ 120 Volts†	1.1
Amps @ 120 Volts	9
Heating Element (BTU/HR)	22,000
Product Weight	130 Lbs.
Shipping Weight	140 Lbs.

27" Front Load Washer

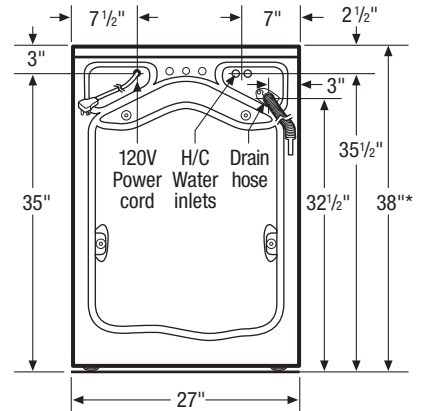

*53" with optional pedestal

27" Front Load Dryer

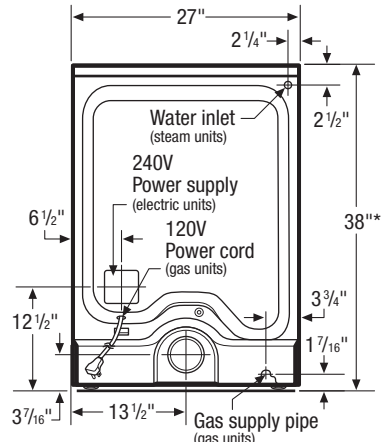

*53" with optional pedestal

Note: Steam units require 3/4" steam hose clearance from back of unit to wall

Dimensions	Side-by-Side Installation	Stacked Installation
Cutout –		
Height	38" min.	75-3/4" min.
Width	54" min.	27" min.
Depth (Non-Steam Units) (Steam Units)	31-1/2" min. 32-1/4" min.	31-1/2" min. 32-1/4" min.*
Overall Exterior –	27" Washers	27" Dryers
Height (Without 15" Pedestal) (With 15" Pedestal)	38" 53"	38" 53"
Width	27"	27"
Depth (to Center of Arc)	31-1/2" Not Including Hose	31-1/2" Including Exhaust
Depth (with 90° Door Open)	50-5/8"	50-5/8"

*To achieve minimal depth dimensions or clearances, dryer MUST be vented straight back or with quick-turn 90° elbow. Side-by-Side units in under-counter installation require custom-built countertop and/or cabinetry. Note: For planning purposes only. Refer to Product Installation Guide on the web at electroluxappliances.com for detailed instructions.

Accessories and Electrolux Platinum Star™ Service & Warranty information available on the web at www.electroluxappliances.com

Electrolux Major Appliances, N.A.

USA • 250 Bobby Jones Expressway • Augusta, GA 30907 • 1-877-4electrolux (1-877-435-3287) • electroluxappliances.com
CANADA • 5855 Terry Fox Way • Mississauga, ON L5V 3E4 • 1-800-265-8352 • electroluxappliances.ca

