



ELICA'S EXCLUSIVE
PLUS FEATURES

When the view out of your kitchen window is too spectacular to disrupt it with a large range hood, Elica's SIENA is the perfect solution. Siena literally installs into the ceiling and is discreetly flush mounted, which allows the cabinetry and outdoors to take center stage. However, when it's time to cook, Siena will easily do the job.

SIENA has a powerful 600 CFM and in-line blower, (sold separately) which is mounted in the attic for added silence and peacefulness. The 43" x 27" size provides excellent capture area, and in addition Perimeter Aspiration Technology has been included increasing suction by 35%, making SIENA a highly effective hood despite its out-of-sight location.

SIENA's bright LED lighting and 4 speed blower are conveniently operated by an ergonomic remote control.

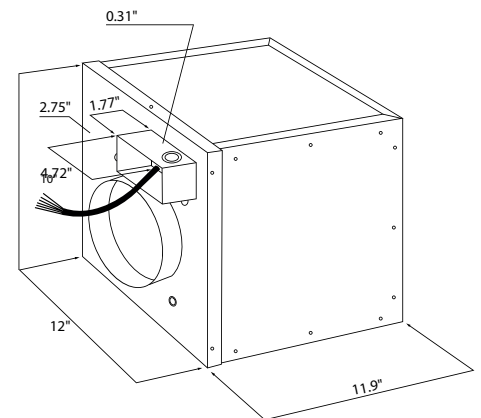
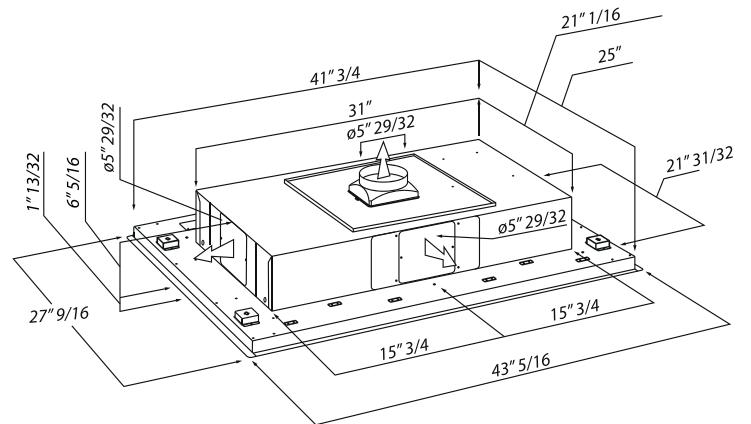

MOUNTING
HEIGHT
RANGE

SPECIFICATIONS



	43" UNIT
Model: Dimensions: Blower Type(internal): Blower Performance: Speed 1 Speed 2 Speed 3 Speed 4 Noise (sones): Woking Speed Finish: Controls: Illumination: Filter Type: Number of filters: Installation Type: Electrical:	<p>ESNX43S2 (requieres in line blower ESNBLK26 sold separately) 43"W x 27"D x 7 23/32"H 600 CFM, 4 speed in-line blower (Sold Separately)</p> <p>160 CFM 280 CFM 470 CFM 600 CFM -</p> <p>Stainless Steel Remote Control 4 LED 2.5 W</p> <p>Dishwasher-safe aluminum mesh grease filters + stainless steel perimeter aspiration plate 1 Ducted out 120V - 60Hz, 445 Watts at 3,7 Amps</p>
KITS: In line blower SEM1 US 120V	ESNBLK26
CONSUMABLE PARTS: Replacement Light Bulb (1) Anodized Aluminium Mesh Grease Filter (1)	2006BH GRI0116546

*The product images shown are for illustration purposes only and may not be an exact representation of the product.

PLUS FEATURES



BLOWER KIT - Elica Blower KITS offers installation flexibility that will accommodate most construction requirements, plus provides options related to ventilation power and sound generation.



REMOTE CONTROL - Elica's ADA compliant Remote Control, provides added convenience to the typical user, as well as, full function access for those with limited mobility.



AMBIENT LIGHT - Elica studies on hood lighting leaves no stone unturned. Here we have thought about products not only able to light the cooktop, but the entire kitchen space. And so the hood is transformed: from a kitchen appliance to a true lighting element. Considering the design of Elica hoods, it is not hard to imagine how this option is quite unique, and represents one extraordinary point of strength for us.



TOP PERFORMANCE - Excellent performance for models equipped with this plus. High fume capturing capacity with an average aspiration range of 600 CFM's. with low noise levels, 1.2 - 1.7 sones at working speed.



PERIMETER ASPIRATION - First developed by Elica, this technology literally turned the market 180 degrees and opened the door to hoods that could be mounted on the wall like picture frames. The technology draws air through a narrowed channel around a face plate, which increases suction, without increasing blower speed or energy consumption.



LED LIGHT - LED lighting is undoubtedly the smartest solution in terms of energy saving. Expected life time of over 20.000 hours, represents the most remarkable advantage of LED light bulbs.