

DF606DG



FEATURES

- 6 dual-stacked burners plus 30,000 Btu dual griddle
- Over 9 cubic feet of dual convection capacity in two ovens
- 10 cooking modes make meals easy
- Dual-stacked burners go from 20,000 Btu down to a mere breath of flame
- Continuous cast-iron grates for easy movement of pots and pans
- Cobalt blue porcelain interior
- Rigorously tested in our U.S. manufacturing facilities for decades of use
- Exceptional 24/7 support from our Customer Care team in Madison
- Dual convection oven for faster, more consistent cooking
- Individual spark ignition system
- Heavy-gauge stainless steel
- Exclusive pivoting control panel
- Red, black or stainless steel control knobs
- Temperature probe lets you know when it's done
- Self clean, delayed start, timed cook, Sabbath mode and more

ACCESSORIES

- Bake stone kit (stone, rack and peel)
- Stainless steel, brass or chrome bezels
- Front leg and rear caster covers
- High altitude conversion kit
- Dehydration kit (racks and door stop)
- Full-extension easy glide oven rack
- Cast iron S-grates and wok grate
- Stainless steel kickplate
- Signature red, black or stainless steel control knobs
- Temperature probe and broiler pan
- 5" and 10" stainless steel risers, and 20" riser with shelf
- Set of three standard oven racks
- Hardwood cutting board

Accessories available through an authorized Sub-Zero dealer.
For local dealer information, visit subzero-wolf.com/locator.



KNOB OPTIONS



TOP CONFIGURATION

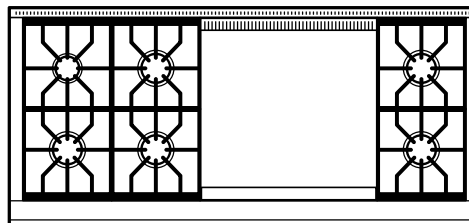

RANGETOP SPECIFICATIONS

- 1 - 9,200 Btu Burner
- 1 - 30,000 Btu (26,000 Btu LP) Double Griddle

PRODUCT SPECIFICATIONS

Model	DF606DG
Dimensions	60 1/8"W x 36 7/8"H x 29 1/2"D
Door Clearance	19 1/2"
Weight	950 lb
Oven 1 Interior Dimensions	25"W x 16 1/2"H x 19"D
Oven 2 Interior Dimensions	25"W x 16 1/2"H x 19"D
Oven 1 Usable Capacity	2.8 cu ft each
Oven 1 Overall Capacity	4.5 cu ft each
Oven 2 Usable Capacity	2.8 cu ft each
Oven 2 Overall Capacity	4.5 cu ft each
Electrical Supply	240/208 VAC, 60 Hz
Electrical Service	50 amp dedicated circuit
Gas Supply	3/4" rigid pipe
Gas Inlet	1/2" NPT female

ELECTRICAL AND GAS

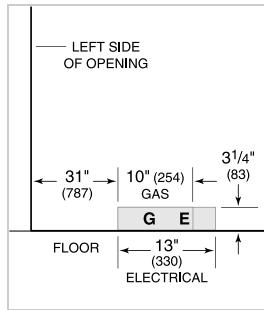

DIMENSIONS

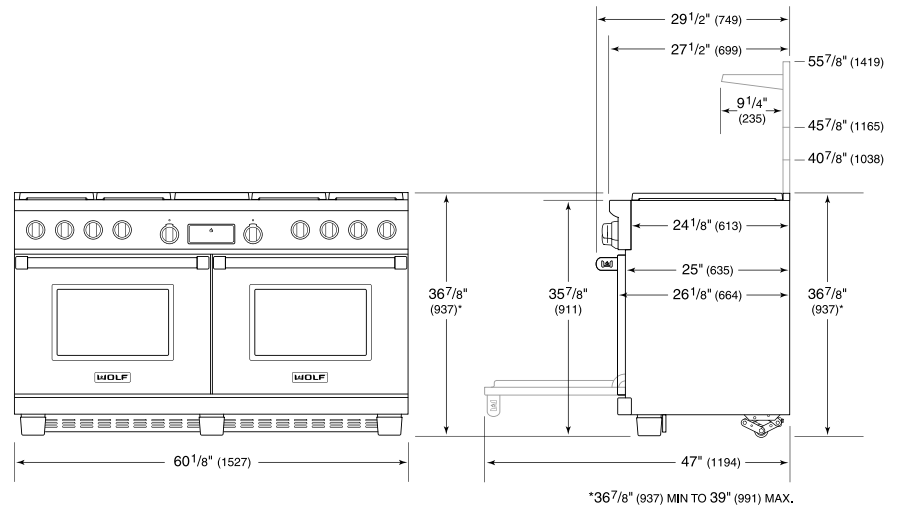

INSTALLATION

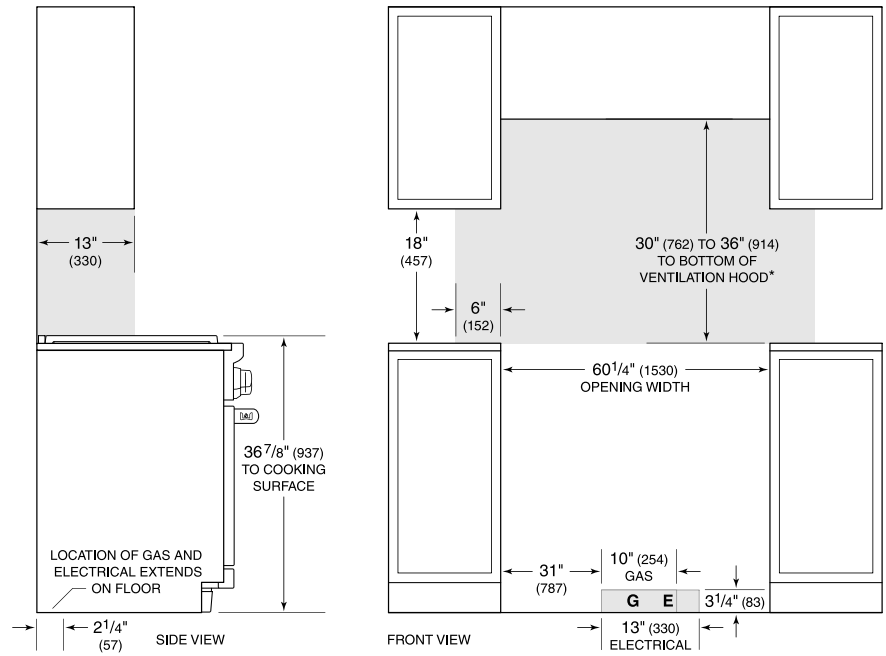

*Without ventilation hood, 36" (914) minimum clearance countertop to combustible materials, 44" (118) for charbroiler.

NOTE: Shaded area above countertop indicates minimum clearance to combustible surfaces, combustible materials cannot be located within this area.

For island installation, 12" (305) minimum clearance back of range to combustible rear wall above countertop.