

60" DUAL FUEL RANGE - 4 BURNERS, INFRARED CHARBROILER AND FRENCH TOP



DF604CF



FEATURES

4 dual-stacked burners plus 16,000 charbroiler and 15,000 Btu French top

Over 9 cubic feet of dual convection capacity in two ovens

10 cooking modes make meals easy

Dual-stacked burners produce up to 20,000 Btu

Burners capable of delivering less than 300 Btu for premier simmer performance

Heavy-gauge stainless steel

Rigorously tested in our U.S. manufacturing facilities for decades of use

Exceptional 24/7 support from our Customer Care team in Madison

Continuous cast-iron grates for easy movement of pots and pans

Cobalt blue porcelain interior

Dual convection oven for faster, more consistent cooking

Spark ignition system re-ignites when flame goes out

Exclusive pivoting control panel

Red, black or stainless steel control knobs

Temperature probe lets you know when it's done

Self clean, delayed start, timed cook, Sabbath mode and more

ACCESSORIES

Bake stone kit (stone, rack and peel)

Stainless steel, brass or chrome bezels

Front leg and rear caster covers

High altitude conversion kit

Dehydration kit (racks and door stop)

Full-extension easy glide oven rack

Cast iron S-grates and wok grate

Stainless steel kickplate

Signature red, black or stainless steel control knobs

Temperature probe and broiler pan

5" and 10" stainless steel risers, and 20" riser with shelf

Set of three standard oven racks

Accessories available through an authorized Sub-Zero dealer.
For local dealer information, visit subzero-wolf.com/locator.



KNOB OPTIONS



TOP CONFIGURATION

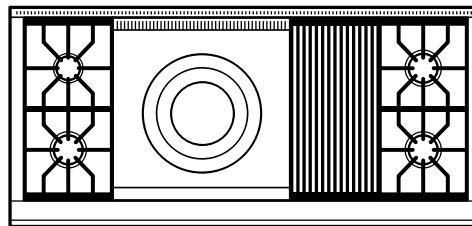

RANGETOP SPECIFICATIONS

- 1 - 9,200 Btu Burner
- 1 - 15,000 Btu Burner
- 1 - 18,000 Btu Burner
- 1 - 20,000 Btu Burner
- 1 - 16,000 Btu Charbroiler
- 1 - 15,000 Btu French Top

PRODUCT SPECIFICATIONS

Model	DF604CF
Dimensions	60 1/8"W x 36 7/8"H x 29 1/2"D
Oven 1 Interior Dimensions	25"W x 16 1/2"H x 19"D
Oven 2 Interior Dimensions	25"W x 16 1/2"H x 19"D
Oven 1 Usable Capacity	2.8 cu ft
Oven 1 Overall Capacity	4.5 cu ft
Oven 2 Usable Capacity	2.8 cu ft
Oven 2 Overall Capacity	4.5 cu ft
Door Clearance	19 1/2"
Weight	950 lb
Electrical Supply	240/208 VAC, 60 Hz
Electrical Service	50 amp dedicated circuit
Gas Supply	3/4" rigid pipe
Gas Inlet	1/2" NPT female

ELECTRICAL AND GAS

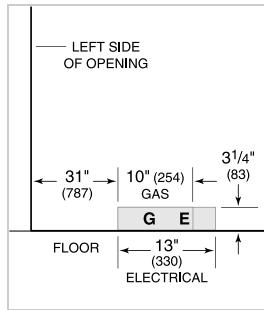

DIMENSIONS

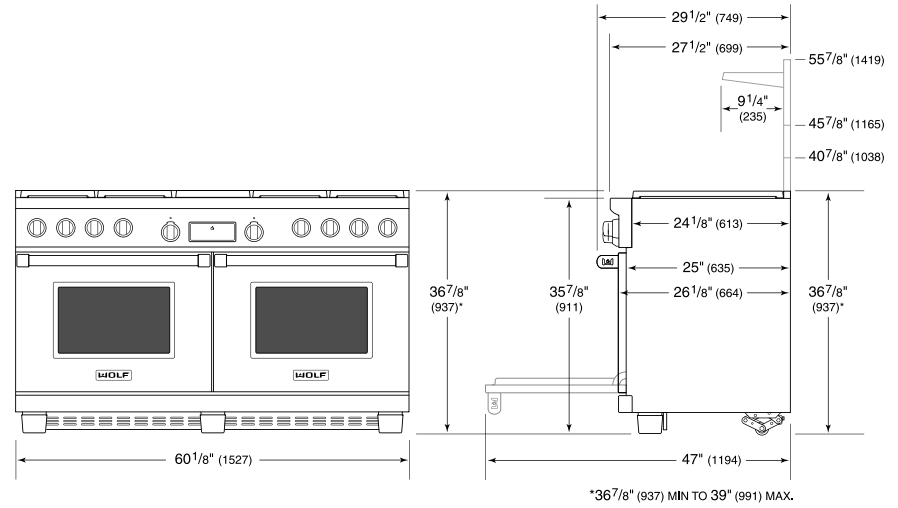

STANDARD INSTALLATION

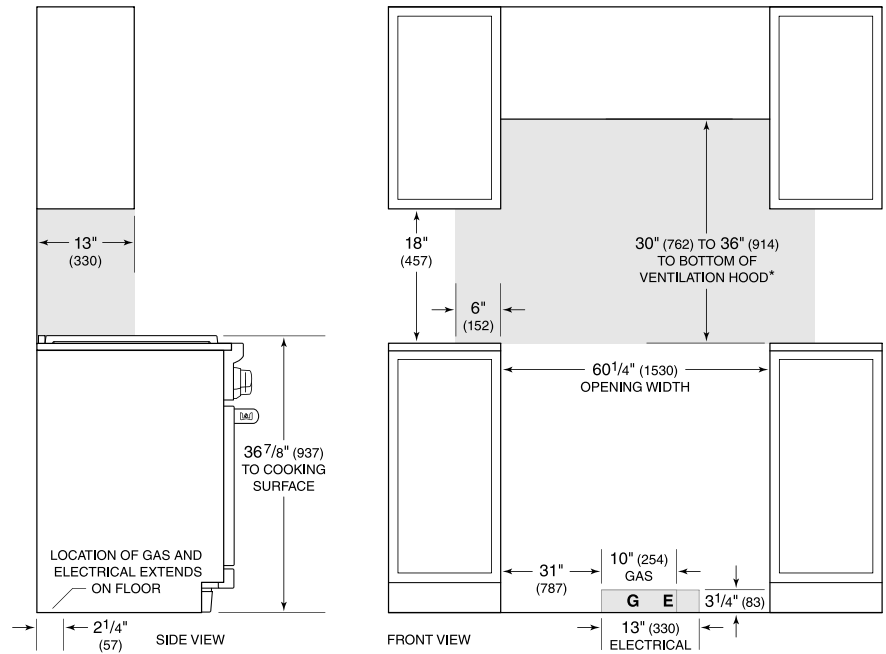

*Without ventilation hood, 36" (914) minimum clearance countertop to combustible materials, 44" (118) for charbroiler.

NOTE: Shaded area above countertop indicates minimum clearance to combustible surfaces, combustible materials cannot be located within this area.

For island installation, 12" (305) minimum clearance back of range to combustible rear wall above countertop.