

PWO, MWO, IWO CUSTOM PANEL



062805

Warming Oven Custom Panel

1/1

PLANNING GUIDE

IWO CUSTOM PANEL

Cut the custom panel to desired length and height. Use a high temperature rated double faced adhesive tape to apply panel thicknesses up to 1/4" (6mm). Use screws to attach panels thicker than 1/4" (6mm).

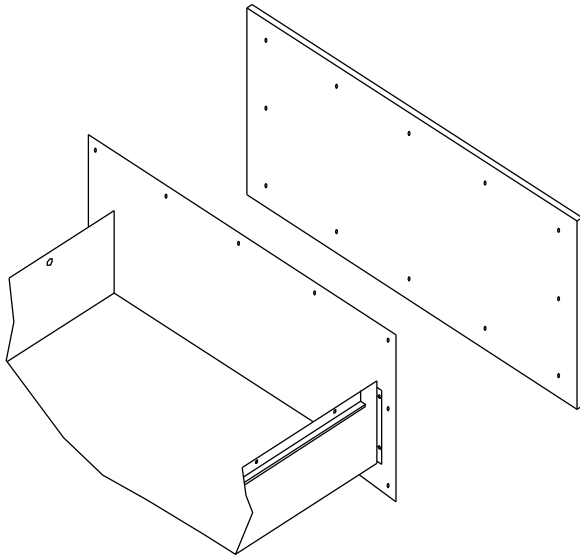

IWO INSTALLATION

MWO & PWO CUSTOM PANELS

For thicker panels: Along the top 1/4" (6mm) of the custom panel, it will be necessary to route the top edge of panel to a thickness of 1/8" (3mm) if the panel thickness is greater than 1/8" (3mm). This will enable the custom panel to slide under the thicker handle. Additional routing may be required around the Moist-Crisp knob and slide, if a panel greater than 1/8" (3mm) thick is used.

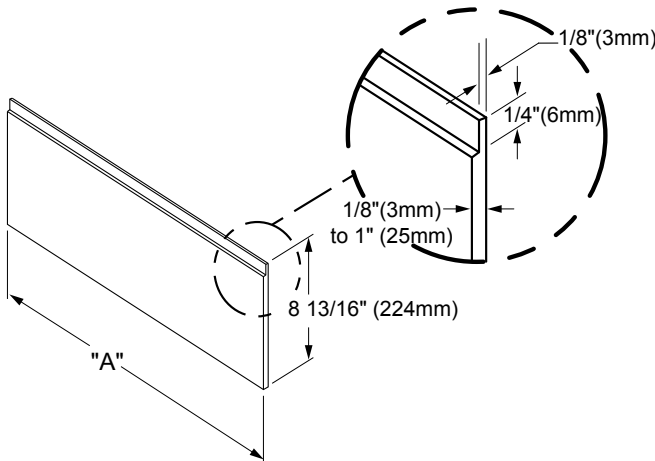

MWO & PWO DIMENSIONS

Model No.	"A" Panel Width
MWO27	27" (686mm)
MWO30	30" (762mm)
PWO30	

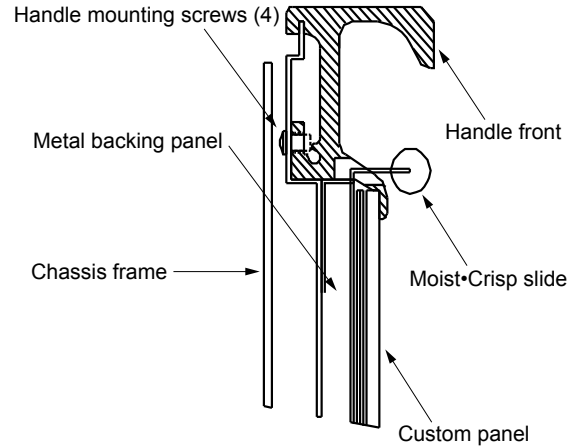

MWO SIDE VIEW

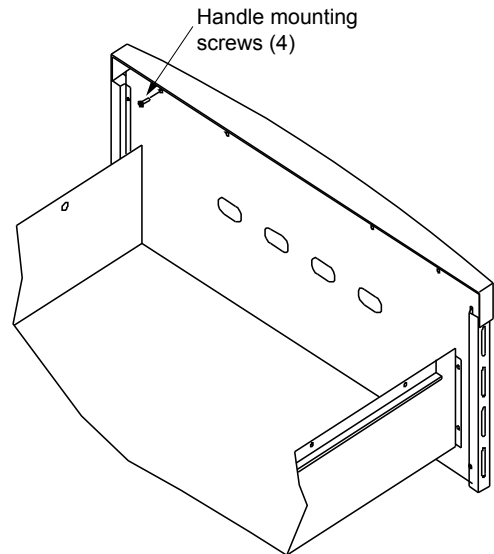

PWO REAR VIEW

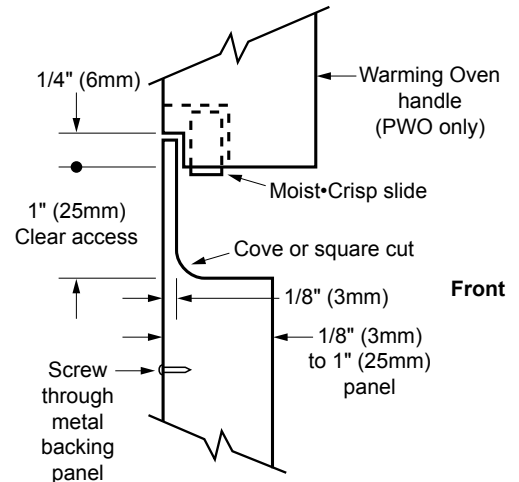

PWO SIDE VIEW