

## **BLUESTAR 36" RCS SERIES**

With over 130 years of experience making cooking equipment, and as the leading manufacturer of high-performance commercial-style ranges for the home, it is no surprise that BlueStar™ makes the finest residential ranges available. The unparalleled accuracy of gas surface cooking and the versatility found in the baking and roasting qualities of our convection oven make this an unsurpassed addition to every cook's favorite room in the house.

Heavy-duty construction combined with innovative features produce an appliance of uncompromising durability, functionality, and beauty that will be the focal point of your kitchen for years to come!

### **BlueStar 36" RCS Series**

- Extra large oven capacity: 29"W x 20"D x 15"H.
- Accommodates a full-size commercial 18" x 26" baking sheet.
- 24" depth for compatibility with standard kitchen cabinetry.
- 30" Island trim comes standard.

*Model RCS366BSS shown ▶  
with optional 6" backguard.*

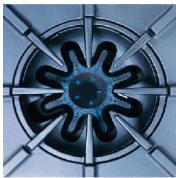

#### **NOVA™ and Simmer Burners**

Our cast iron porcelain-enamelled NOVA™ top burners are the most versatile burners in the industry. The NOVA™ burner provides up to 15,000 BTU's of cooking power; a rapid boil or superior sauté is never a problem! When using our gentle 130°F simmer feature, delicate sauces and soups are made simple with superior temperature control and flame disbursement.



#### **Infrared Broiler**

Because of its popularity in the commercial market, the direct-fired ceramic infrared broiler is standard on all residential ranges. The large burner produces 1850 °F of intense, searing heat close to the burner, while effecting a gentler broiling for foods placed farther away. The broiler is fully recessed into the oven's top to create maximum cooking space.



#### **Full Motion Grates**

Bring sauce to a boil while stirring on a front burner, then slide it to the rear to simmer while you sauté up front! Our full motion grates allow you to easily reposition pots and pans from front to rear burners without lifting. The grates are also oversized to accommodate the largest stock pots and sauté pans.

# BLUESTAR 36" RCS SERIES

## Standard Features

- Heavy-duty, commercial stainless steel construction.
- Automatic electronic ignition and re-ignition system.
- Interior oven light.
- Ceramic infra-red broiler.
- Commercial quality oven control.
- Heavy-duty oven door.
- Push-to-turn, infinite setting NOVA™ top burner controls with new 130 °F simmer burner.
- Heavy-duty steel alloy control knobs.
- Removable dishwasher friendly stainless steel drip trays.
- Extra large oven capacity. 29"W x 20"D x 15"H.
- 1 year parts and labor warranty.

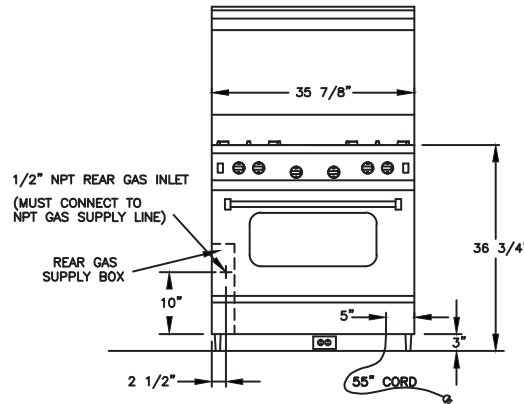

ELECTRICAL CORD LOCATED IN BACK OF UNIT  
LOCATION OF ELECTRICAL OUTLET MUST NOT BE HIGHER THAN 3" FROM FLOOR IF LOCATED BEHIND THE UNIT OR CAN BE LOCATED IN AN ADJOINING CABINET.

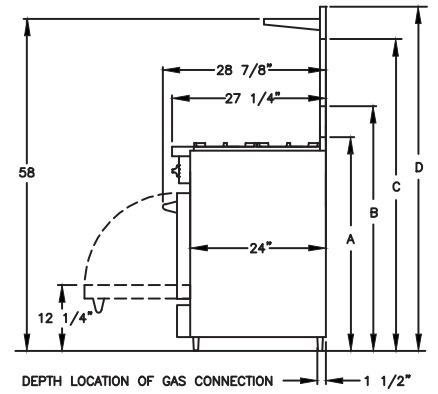

A - ISLAND TRIM HEIGHT - 38 1/4"  
B - 6" STANDARD BACKGUARD HEIGHT - 43 1/4"  
C - 17" BACKGUARD HEIGHT - 54 1/4"  
D - HIGH SHELF BACKGUARD HEIGHT - 61"

Top Burner Rating .....	15,000 BTU	Simmer Burner Rating .....	9,000 BTU, 130°F
Top Power Burner Rating .....	15,000 BTU	Electrical Requirements .....	120 VAC, 15 Amps (Unit must be on a non-GFI, dedicated outlet) Single Phase
Infrared Broiler Rating .....	15,000 BTU	Operating Gas Pressure .....	NAT: 5.0" WC LP: 10.0" WC
Oven Burner Rating .....	30,000 BTU	Installation Clearance .....	0" Side Cabinet 0" Back Wall

\*\* All specifications are subject to change without prior notification.

## BlueStar Backguard Options



### Island Trim Back

Allows flush-mounting into an island. Oven vents through top of back.

(Shown on 36" Model)



### 6" Low Profile Back

Protects the back wall while allowing for custom treatment.

(Shown on 24" Model)



### 17" Backguard

Provides commercial aesthetics and professional style.

(Shown on 48" Model)



### 24" High Shelf

Produces a true gourmet professional look while providing a convenient holding area for plates and prepared food.

(Shown on 36" Model)

## 36" RCS Series Configuration

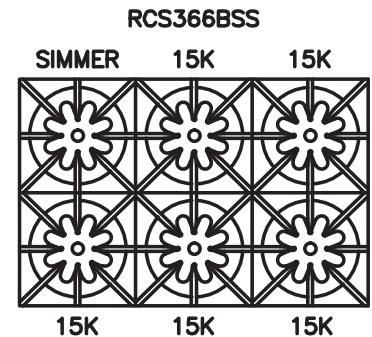

## Accessories

Castors  
Wok Ring

## Additional Products

Cooktops  
Rangetops  
Wall Ovens  
Barbecue Grills  
Hoods  
Warming Drawers  
Indoor Charbroilers  
Salamander Broiler