

BERTAZZONI MASTER SERIES

30" 4-BURNER, GAS OVEN

MAS30 4 GAS XE

HIGHLIGHTS

- Cook with moist gas heat on multiple levels thanks to Bertazzoni balanced airflow and precise temperature control.
- Ranges are controlled by large round soft-touch knobs and feature a professional style handle.
- The one-touch, child safety ignition system lets you light and adjust burners with one hand.
- Thermocouple safety system automatically stops the gas flow if the flame goes out, even when electrical power is cut.



FEATURES

Gas burners	4
Burner type	aluminum
Maintop	one piece stainless steel sheet
Burner controls	knobs
Knobs	soft touch
Grates	cast iron
Backguard	standard 4 inches
Gas safety device	thermocouple technology
One hand ignition	standard
Standard accessories	wok ring & simmer plate
Dual Power burner	750 - 18,000 Btu/h
Rapid burner	11,000 Btu/h
Semi-rapid burner	6500 Btu/h
Auxiliary burner	3400 Btu/h
Simmer rate	750 Btu/h
Main oven	gas convection with gas infrared broiler
Main oven functions	traditional bake, gas convection, broil, defrost/dehydrate, sabbath mode
Main oven volume	3.6 ft ³
Inner oven door	full-width triple glass
Oven equipment	1 baking tray, 2 standard wire shelves, 1 grill trivet for tray
Legs	height adjustable stainless steel legs

TECHNICAL SPECIFICATIONS

Voltage, frequency	120 V, 60Hz
Max Amp Usage, power rating	1.5 A - 150 W
Certification	CSA
Warranty	2 years parts and labor

ACCESSORIES

Toe kick panel (TKS 30 X), flat island trim (IRF 30 X), side trim (ST 36 X)

Available LPG version MAS 30 4 GAS XE LP

A LP conversion kit for all burners is included

MATCHING VENTILATION SOLUTIONS

Bertazzoni offers a variety of matching ventilation solutions for this range. Please check our website under the ventilation tab for a complete overview of all choices



TO COOK BEAUTIFULLY
WWW.BERTAZZONI.COM

INSTALLATION INSTRUCTIONS

MAS30 4 GAS XE

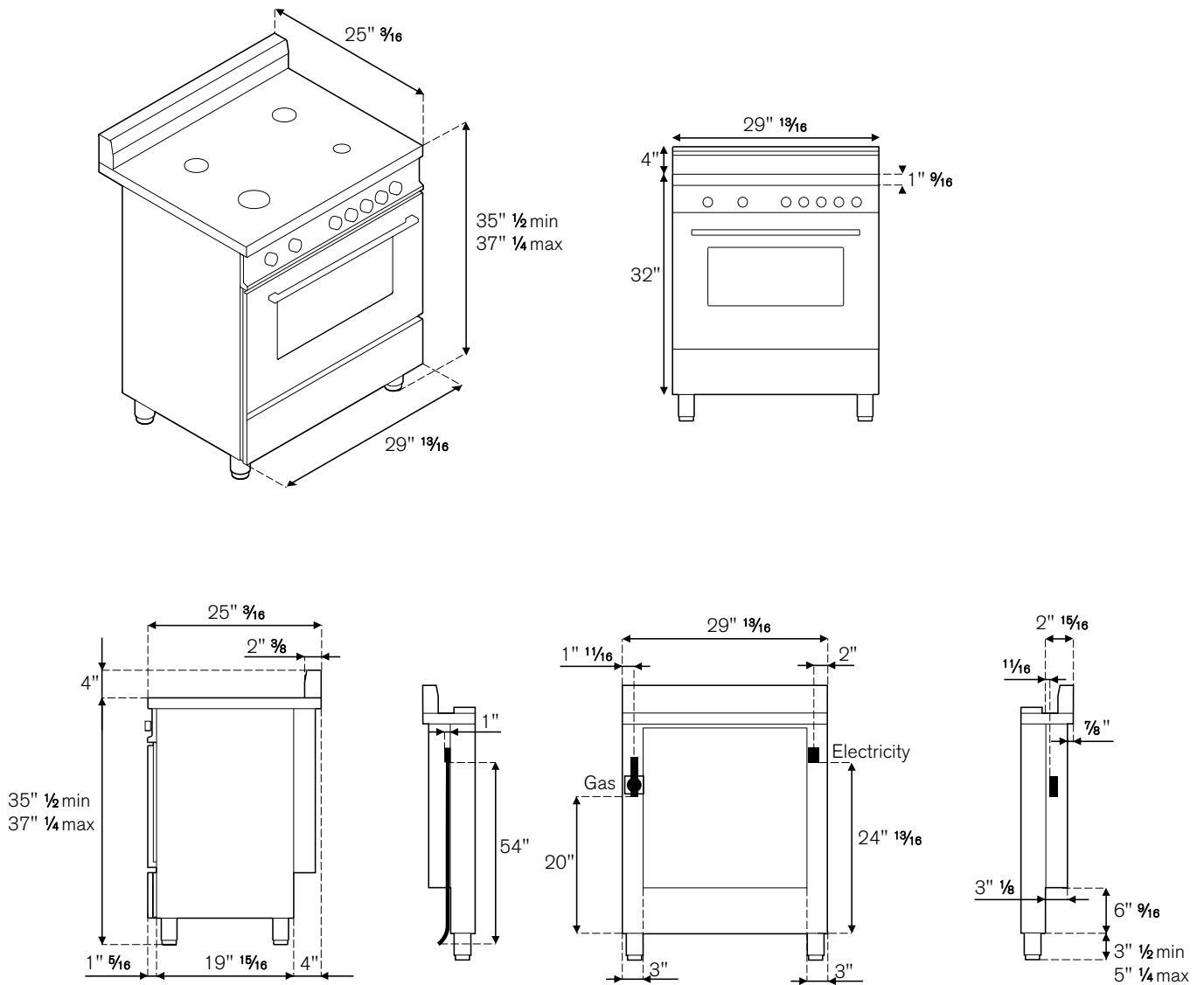

Bertazzoni recommends to operate the appliance after it has been installed in a cabinet. The kitchen cabinets shall be made of materials capable of withstanding temperatures at least 117°F (65°C) above room temperature in order to avoid possible damage to the cabinets during oven usage. For further installation instructions refer to the installation manual.

Disclaimer: while every effort has been made to insure the accuracy of the information contained in this brochure, Fratelli Bertazzoni reserves the right to change any part of the information at any time without notice.

Fratelli Bertazzoni, Bertazzoni and the winged wheel brand icon are registered trademarks of Bertazzoni Spa.