

# FPRO30FDVTX

## PROFESSIONAL SERIES

30" DOUBLE ELECTRIC CONVECTION OVEN IN STAINLESS STEEL  
WITH STEAM ASSIST, SELF-CLEAN AND BERTAZZONI ASSISTANT



### Steam Assist Cooking for Superior Results

This Function enhances cooking by integrating steam into traditional baking and roasting, with three adjustable intensity levels. It delivers crispy exteriors and tender, perfectly cooked interiors while preserving natural flavors and nutrients. The removable 1L water tank, conveniently located in the door, allows for easy refilling and maintenance.

### Enhanced Full Touch TFT Display

The 8.8-inch high-resolution display ensures effortless navigation, featuring an intuitive interface that guides users step by step through cooking functions. This seamless user experience makes even the most advanced cooking techniques accessible to all.

### Bertazzoni Assistant and integrated Food Probe

This cooking assistant streamlines meal preparation by managing settings based on selected recipes. The wired food probe guarantees precise internal temperature control, allowing users to choose their desired doneness level for meats, ensuring optimal flavor and tenderness.

### Expanded Capacity and Enhanced Installation Flexibility

The newly designed oven offers a spacious 4.8 cu.ft. cavity, increasing capacity by 17% compared to previous models. Additionally, the cut-out dimensions have been reduced for easier installation and seamless replacement.

### Smart Connectivity with the Bertazzoni Mobile App

The Bertazzoni Mobile App enables remote control of cooking programs, real-time progress tracking, and access to an integrated recipe book. Additionally, it ensures continuous software updates to optimize performance and introduce new features.

### PRODUCT FEATURES

Oven type	Double Electric Wall Oven
Upper and Lower Oven Power rating (Rating at 240V)	Bake: 3500W Broiler: 3400 W Convection: 2420 W
Oven Volume	4.8 cu.ft.
Lower oven Volume	4.8 cu.ft.
Convection System	1 Fan
User interface	Full Touch 8.8" TFT display
Auto cooking modes	Yes - Bertazzoni Assistant
Cooking modes	Bake, Broil, Convection, Convection bake, Convection broil, Convection roast, Pizza, Air Fry
Special features	Steam Assist, Dehydrate, Proofing, Warming 149 °F, Warming 199 °F, Reheat 248 °F, Sabbath mode
Food temperature probe	Yes
Cleaning	Self Clean, Eco Clean, Hydro Clean, Descale
Shelf levels	7
Bertazzoni Mobile App	Yes
Door hinges	Double Soft Closing
Included accessories (Main cavity)	2 wire shelf flat + 1 wire shelf shaped 2 sets of telescopic glides 1 baking tray with roasting trivet 1 air fry basket
Included accessories (Lower cavity)	2 wire shelf flat + 1 wire shelf shaped 2 sets of telescopic glides 1 baking tray with roasting trivet 1 air fry basket

### TECHNICAL SPECIFICATIONS

Electrical supply	120/208 V 60HZ - 8800 W 120/240 V 60 HZ - 11000 W 50 Amp dedicated circuit
Power connection	Metal conduit with 59" power cord
Certification	cULus
Warranty	2 years parts & labor
Product dimensions	W: 29 7/8" H: 51 1/4" D: 24 1/2"
Cut out dimensions	W: 28 1/2" H: 50 3/8" D: 24 5/8"
Packaging dimensions and weight	W: 33 3/4" H: 59 3/4" D: 29 1/2" 412.5 lbs

# FPRO30FDVTX

## PROFESSIONAL SERIES

30" DOUBLE ELECTRIC CONVECTION OVEN IN STAINLESS STEEL  
WITH STEAM ASSIST, SELF-CLEAN AND BERTAZZONI ASSISTANT



### PRODUCT DIMENSIONS

SIDE VIEW

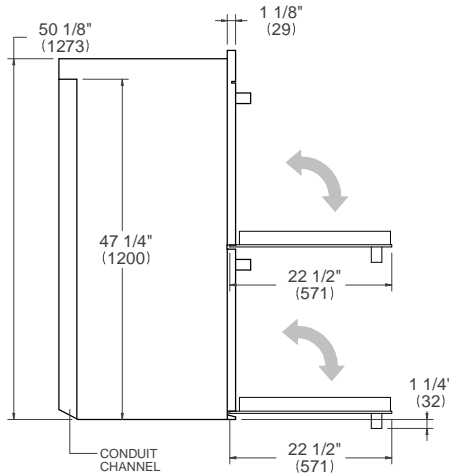

FRONT VIEW

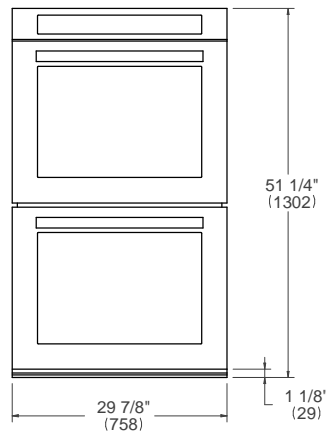

TOP VIEW

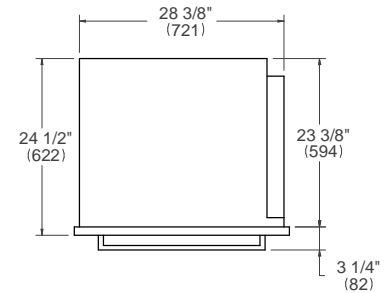

### ELECTRICAL CONNECTION

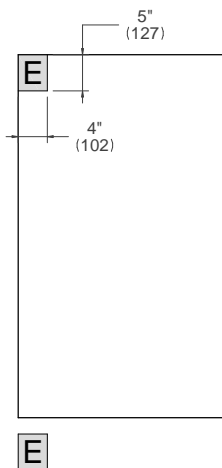

For single ovens installed into a wall cabinet, the electrical junction box may be located above, below to the left or right of the unit within reach of the power cord. Placement within the opening may require additional cabinet depth.

### INSTALLATION REQUIREMENTS

Minimum suggested load on cabinet base board 485 lb (220 kg)

### CUTOUT DIMENSIONS

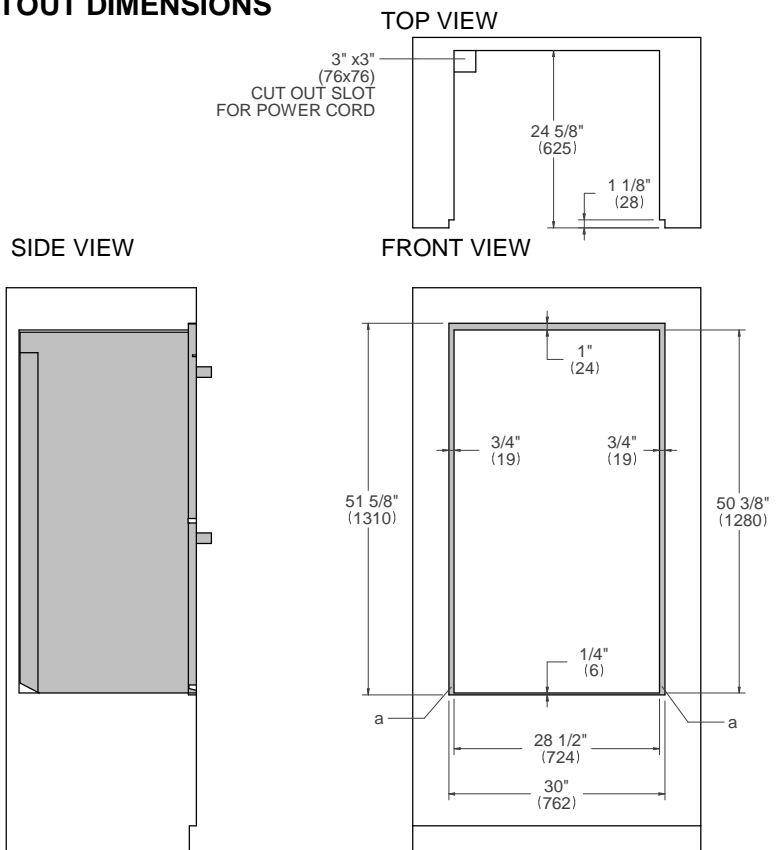

(a) Visible Area – Match finish to cabinetry

For installation of multiple products in combination, refer to the Design Guide at [us.bertazzoni.com](http://us.bertazzoni.com) or [ca.bertazzoni.com](http://ca.bertazzoni.com)

**Disclaimer:** while every effort has been made to ensure the accuracy of the information contained in this document, Fratelli Bertazzoni reserves the right to change it at any time without notice. For detailed installation instructions, consult the installation manual. Fratelli Bertazzoni, Bertazzoni and the winged wheel brand icon are registered trademarks of Bertazzoni Spa.