

Food Waste Disposers



Submittal Sheet

This model offers the following features and benefits:

- 1/3 Horsepower Heavy Duty Motor (Quiet Dura-Drive® Induction Motor)
- 1-Year *We Come To You*™ In-Home Parts And Labor Service Warranty
- Rugged Galvanized Steel Construction (For Disposer Durability)
- Space-Saving Compact Design

Specifications

Type of Feed	Continuous
On/Off Control	Wall Switch
Motor	Single Phase
HP	1/3
Volts	120
HZ	60
RPM	1725
Amp. (Avg. Load)	6.7
Time Rating	Intermittent
Lubrication	Permanently Lubricated Upper & Lower Bearings
Shipping Weight (Approx.)	13 lbs. 8oz.
Unit Finish	Waterborne Grey Enamel
Overall Height	11-3/8"
Grind Chamber Capacity	32 oz.
Motor Protection	Manual Reset Overload
Average Water Usage	1/4 Gallon per Person Per Day
Average Electrical Usage	1/2 KWH per Month
Drain Connection	1-1/2" Cushioned Slip Joint
Dishwasher Drain Connection	Yes

Dimensions

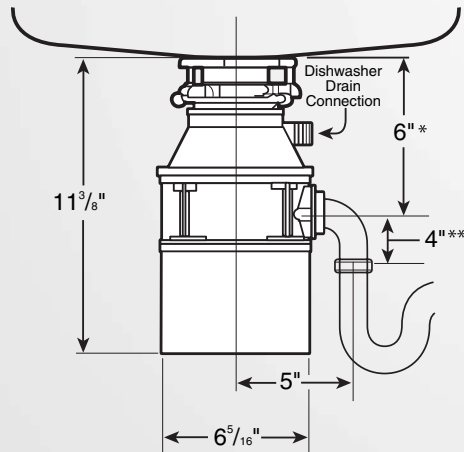

- * Distance from bottom of sink to center line of disposer outlet. Add 1/2" when stainless steel sinks are used.
 ** Length of tailpipe from center line of disposer outlet to end of tailpipe.
 NOTE: Plumb waste line to prevent standing water in disposer motor housing.

Sample Specification

Food Waste Disposer(s) shall be InSinkErator Badger 1, continuous feed, with 1/3 H.P. motor, galvanized steel grinding elements with two stainless steel 360° swivel lugs. Exclusive self-service wrench.

Warranty:
 1-Year parts and in-home service.

* The complete InSinkErator warranty is included in the Care & Use Booklet packed with each unit.

Job Specifications

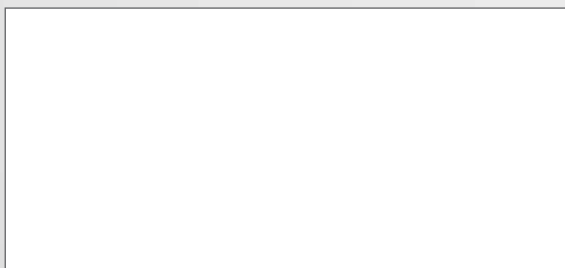

1-800-558-5700
www.insinkerator.com



The Emerson logo is a trademark and service mark of Emerson Electric Co.
 InSinkErator is a division of Emerson Electric Co.