

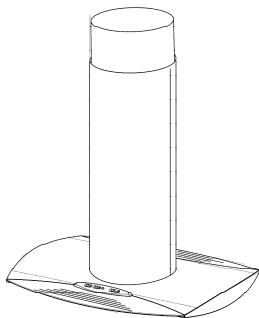

FABER



Axia Isola^{plus}

Island Mount Canopy Rangehood

- Installation Instructions
- Use and Care Information

READ AND SAVE THESE INSTRUCTIONS

The Installer must leave these instructions with the homeowner. The homeowner must keep these instructions for future reference and for local electrical inspectors' use.

READ THESE INSTRUCTIONS BEFORE YOU START INSTALLING THIS RANGEHOOD

WARNING: - TO REDUCE THE RISK OF A RANGE TOP GREASE FIRE: a) Never leave surface units unattended at high settings. Boilovers cause smoking and greasy spillovers that may ignite. Heat oils slowly on low or medium setting. b) Always turn hood ON when cooking at high heat or when flambeing food (i.e. Crepes Suzette, Cherries Jubilee, Peppercorn Beef Flambé). c) Clean ventilating fans frequently. Grease should not be allowed to accumulate on fan or filter. d) Use proper pan size. Always use cookware appropriate for the size of the surface element.

WARNING: - TO REDUCE THE RISK OF INJURY TO PERSONS IN THE EVENT OF A RANGE TOP GREASE FIRE, OBSERVE THE FOLLOWING: SMOTHER FLAMES with a close-fitting lid, cookie sheet, or metal tray, then turn off the burner. **BE CAREFUL TO PREVENT BURNS.** If the flames do not go out immediately **EVACUATE AND CALL THE FIRE DEPARTMENT. NEVER PICK UP A FLAMING PAN - You may be burned. DO NOT USE WATER, including wet dishcloths or towels - a violent steam explosion will result. Use an extinguisher ONLY if:** 1. You know you have a Class ABC extinguisher, and you already know how to operate it. 2. The fire is small and contained in the area where it started. 3. The fire department is being called. 4. You can fight the fire with your back to an exit.

ALL WALL AND FLOOR OPENINGS WHERE THE RANGEHOOD IS INSTALLED MUST BE SEALED.

This rangehood requires at least 24" of clearance between the bottom of the rangehood and the cooking surface or countertop. This minimum clearance may be higher depending on local building code. For example, for gas ranges, a minimum of 30" may be required. The maximum depth of overhead cabinets is 13". Overhead cabinets on both sides of this unit must be a minimum of 18" above the cooking surface or countertop. Consult the cooktop or range installation instructions given by the manufacturer before making any cutouts. **MOBILE HOME INSTALLATION** The installation of this rangehood must conform to the Manufactured Home Construction and Safety Standards, Title 24 CFR, Part 3280 (formerly Federal Standard for Mobile Home Construction and Safety, Title 24, HUD, Part 280). Four wire power supply must be used and the appliance wiring must be revised. See Electrical Requirements.

LISEZ BIEN CETTE FICHE AVANT D'INSTALLER LA HOTTE

AVERTISSEMENT - POUR MINIMISER LE RISQUE D'UN FEU DE GRAISSE SUR LA TABLE DE CUISSON : a) Ne jamais laisser un élément de la table de cuisson fonctionner sans surveillance à la puissance de chauffage maximale; un renversement/débordement de matière grasseuse pourrait provoquer une inflammation et le génération de fumée. Utiliser toujours une puissance de chauffage moyenne ou basse pour le chauffage d'huile. b) Veiller à toujours faire fonctionner le ventilateur de la hotte lors d'une cuisson avec une puissance de chauffage élevée ou lors de la cuisson d'un mets à flamber (i.e. Crepes Suzette, Cherries Jubilee, Peppercorn Beef Flambé). c) Nettoyer fréquemment les ventilateurs d'extraction. Veiller à ne pas laisser de la graisse s'accumuler sur les surfaces du ventilateur ou des filtres. d) Utiliser toujours un ustensile de taille appropriée. Utiliser toujours un ustensile de taille adapté à la taille de l'élément chauffant.

AVERTISSEMENT: - POUR PRÉVENIR LES BLESSURES EN CAS DE FEU SUIVRE LES RECOMMANDATIONS SUIVANTES: ÉTOUFFEZ LE FEU avec un couvercle métallique et fermez le brûleur. Si le feu ne s'éteint pas tout de suite, **QUITTEZ LES LIEUX ET APPELEZ LES POMPIERS. NE TOUCHEZ JAMAIS UNE CASSEOLE EN FLAMMES. N'UTILISEZ JAMAIS DE L'EAU** ou un torchon mouillé pour éteindre le feu - ce qui pourrait causer une explosion de vapeur. N'utilisez un extincteur que si: 1. Vous avez un modèle ABC et vous connaissez bien son mode d'emploi. 2. Le feu est petit et peu répandu. 3. Les pompiers sont déjà prévenus. 4. Vous avez une sortie derrière vous.

TOUTE OUVERTURE DANS LE MUR OU LE PLANCHER À PROXIMITÉ DE LA HOTTE DOIT ÊTRE SCELLÉ

Gardez 24 po. de hauteur entre le bas de la hotte et la surface de cuisson. Cette hauteur minimum peut être plus haute suivant le code municipal. Par exemple, les cuisinières à gaz peuvent requérir 30 po. de hauteur. Les armoires au-dessus ne dépasseront pas 13 po. de profondeur. Les armoires au-dessus de chaque côté devront être au moins à 18 po. au-dessus de la surface de cuisson. Consultez la fiche technique avant de découper les armoires. L'installation de cette hotte doit être conforme aux Règlements de Manufactured Home Construction and Safety Standards, titre 24 CFR, Section 3280 (anciennement Federal Standard for Mobile Home Construction and Safety Standards, titre 24 CFR, Section 3280 (anciennement Federal Standard for Mobile Home Construction and Safety, titre 24, HUD, Section 280). Le branchement électrique se fait avec une raccordement à 4 fils. Consultez la fiche technique électrique.

VENTING REQUIREMENTS

Determine which venting method is best for your application. Ductwork can extend either through the wall or the roof.

The length of the ductwork and the number of elbows should be kept to a minimum to provide efficient performance. The size of the ductwork should be uniform. Do not install two elbows together. Use duct tape to seal all joints in the ductwork system. Use caulking to seal exterior wall or floor opening around the cap.

Flexible ductwork is not recommended. Flexible ductwork creates back pressure and air turbulence that greatly reduces performance.

Make sure there is proper clearance within the wall or floor for exhaust duct before making cutouts. Do not cut a joist or stud unless absolutely necessary. If a joist or stud must be cut, then a supporting frame must be constructed.

FOR MORE SPECIFIC DUCTWORK INFORMATION, GO TO PAGE 4.

WARNING - To Reduce The Risk Of Fire, Use Only Metal Ductwork.



WARNING

- Venting system MUST terminate outside the home.
- DO NOT terminate the ductwork in an attic or other enclosed space.
- DO NOT use 4" laundry-type wall caps.
- Flexible-type ductwork is not recommended.
- DO NOT obstruct the flow of combustion and ventilation air.
- Failure to follow venting requirements may result in a fire.

ELECTRICAL REQUIREMENTS

A 120 volt, 60 Hz AC-only electrical supply is required on a separate 15 amp fused circuit. A time-delay fuse or circuit breaker is recommended. The fuse must be sized per local codes in accordance with the electrical rating of this unit as specified on the serial/rating plate located inside the unit near the field wiring compartment. THIS UNIT MUST BE CONNECTED WITH COPPER WIRE ONLY. Wire sizes must conform to the requirements of the National Electrical Code, ANSI/NFPA 70 - latest edition, and all local codes and ordinances. Wire size and connections must conform with the rating of the appliance. Copies of the standard listed above may be obtained from:

National Fire Protection Association
Batterymarch Park
Quincy, Massachusetts 02269

For residential use only.

This appliance should be connected directly to the fused disconnect (or circuit breaker) through flexible, armored or nonmetallic sheathed copper cable. Allow some slack in the cable so the appliance can be moved if servicing is ever necessary. A UL Listed, 1/2" conduit connector must be provided at each end of the power supply cable (at the appliance and at the junction box).

When making the electrical connection, cut a 1 1/4" hole in the wall. A hole cut through wood must be sanded until smooth. A hole through metal must have a grommet.

WARNING - TO REDUCE THE RISK OF FIRE OR ELECTRIC SHOCK, do not use this fan with any solid-state speed control device.

WARNING - TO REDUCE THE RISK OF FIRE, ELECTRICAL SHOCK, OR INJURY TO PERSONS, OBSERVE THE FOLLOWING: Use this unit only in the manner intended by the manufacturer. If you have any questions, contact the manufacturer.

Before servicing or cleaning unit, switch power off at service panel and lock the service disconnecting means to prevent power from being switched on accidentally. When the service disconnecting means cannot be locked, securely fasten a prominent warning device, such as a tag, to the service panel.

CAUTION: For General Ventilating Use Only. Do Not Use To Exhaust Hazardous or Explosive Materials and Vapors.

WARNING - TO REDUCE THE RISK OF FIRE, ELECTRICAL SHOCK, OR INJURY TO PERSONS, OBSERVE THE FOLLOWING: Installation Work And Electrical Wiring Must Be Done By Qualified Person(s) In Accordance With All Applicable Codes And Standards, Including Fire-Rated Construction.

Sufficient air is needed for proper combustion and exhausting of gases through the flue (chimney) of fuel burning equipment to prevent backdrafting. Follow the heating equipment manufacturer's guideline and safety standards such as those published by the National Fire Protection Association (NFPA), and the American Society for Heating, Refrigeration and Air Conditioning Engineers (ASHRAE), and the local code authorities.

When cutting or drilling into wall or ceiling, do not damage electrical wiring and other hidden utilities.

Ducted fans must always be vented to the outdoors.



WARNING

- Electrical ground is required on this rangehood.
- If cold water pipe is interrupted by plastic, nonmetallic gaskets or other materials, DO NOT use for grounding.
- DO NOT ground to a gas pipe.
- DO NOT have a fuse in the neutral or grounding circuit. A fuse in the neutral or grounding circuit could result in electrical shock.
- Check with a qualified electrician if you are in doubt as to whether the rangehood is properly grounded.
- Failure to follow electrical requirements may result in a fire.

RÈGLEMENTS D'ÉVACUATION

Confirmer la sortie d'évacuation - soit par le mur, soit par le toit.

Utilisez une longueur de tuyauterie minimale avec les moindres de coudes pour la plus grande efficacité. Le diamètre de tuyauterie doit être uniforme. N'installez jamais 2 coudes ensemble. Scellez bien tous les joints avec un ruban adhésif métallique à l'intérieur et scellez bien le clapet extérieur avec du calfeutrage.

Utilisez un tuyau d'évacuation rigide lorsque possible. Un tuyau flexible égale deux fois plus qu'un tuyau rigide, ce qui réduit la puissance d'évacuation.

Veillez à ce que l'espace pour le tuyau soit ample - ainsi on n'aurait pas besoin de découper les supports de mur intérieur. Si ce découpage est nécessaire, veillez bien à ce qu'un renforcement soit mis en place.

RÈGLEMENTS D'ÉVACUATION ADDITIONNEL - PAGE 10.

AVERTISSEMENT - Pour Ne Pas Risquer Un Feu, Utilisez Seulement Les Matériaux Métalliques.

⚠ AVERTISSEMENT

- Le système d'évacuation DOIT sortir à l'extérieur.
- N'ÉVACUEZ PAS le conduit soit dans une mansarde soit dans un espace enfermé.
- N'UTILISEZ PAS un clapet de séchoir à 4 pouces.
- N'utilisez pas un conduit flexible.
- N'ENCOMBREZ PAS la circulation d'air.
- Faute de suivre cet avertissement pourrait occasionner un feu.

FICHE TECHNIQUE ÉLECTRIQUE

Le raccordement électrique doit se faire avec un circuit séparé de 15 ampères fusible à 120V, 60 Hz, courant alternatif. On recommande un coupe-circuit. La taille du fusible doit se conformer aux codes municipaux suivant la spécification électrique sur la plaque intérieure. Le diamètre du fil devra aussi se conformer aux règlements du code national électrique, ANSI/NFPA 70 - ainsi qu'aux règlements locaux et les spécifications de cet appareil. On peut obtenir ces informations chez:

L'Association Nationale de la Prévention du Feu
Batterymarch Park
Quincy, Massachusetts 02269

Raccordez cet appareil directement au coupe-circuit avec un fil flexible couvert en cuivre en laissant un peu de lâchement dans le fil pour permettre le déplacement de l'appareil. Veillez à ce qu'un contact d'un demi-pouce (1/2 po.) soit installé à chaque bout de fil (soit à l'appareil ainsi qu'à la boîte à fusible).

Faites un trou de 1 1/4 po. dans le mur. S'il s'agit d'un trou en bois - sablez-le bien, tandis qu'un trou passant par le métal demande un bouche-trou.

AVERTISSEMENT - POUR RÉDUIRE LE RISQUE D'INCENDIE OU DE CHOC ÉLECTRIQUE, ne pas utiliser ce ventilateur en conjonction avec un dispositif de réglage de vitesse à semi-conducteurs.

AVERTISSEMENT – POUR MINIMISER LES RISQUES D'INCENDIE, CHOC ÉLECTRIQUE OU DOMMAGES CORPORELS, OBSERVER LES PRESCRIPTIONS SUIVANTES: Suivez les recommandations du fabricant et entre en communication avec lui pour toute information.

Fermez le courant avant tout entretien et veillez à ce qu'il reste fermé. Si on ne peut pas verrouiller le panneau du service électrique, affichez un avis de danger sur la porte.

AVIS: Pour L'évacuation Générale - Veillez à Ne Pas Evacuer Des Matériaux Ou Vapeurs Explosif.

AVERTISSEMENT – POUR MINIMISER LES RISQUES D'INCENDIE, CHOC ÉLECTRIQUE OU DOMMAGES CORPORELS, OBSERVER LES PRESCRIPTIONS SUIVANTES: L'installation Et Le Raccordement Electrique Doivent Se Faire Par Un Technicien Qualifié Selon Tous Les Codes Municipaux.

Afin d'obtenir un rendement maximal en ce qui a trait à la combustion ainsi qu'à l'évacuation des gaz par la conduite de cheminée, une bonne aération est nécessaire pour tous les appareils à combustion. Suivez les conseils et mesures de sécurité du fournisseur tels que ceux publiés par l'Association Nationale de la Sauvegarde contre l'Incendie et l'Association Américaine d'Ingénieurs de Chauffage, Frigorifaction et Air Climatisé ainsi que les codes municipaux.

En perçant un mur veillez à ne pas perforer un autre fil électrique.

Une ventilateur à évacuation extérieure doit être raccordée à l'extérieur.

⚠ AVERTISSEMENT

- Une prise à terre est nécessaire pour cette hotte.
- N'utilisez pas un tuyau à l'eau froide pour la mise à terre s'il est branché à un joint plastique, non-métallique ou autre.
- NE JOIGNEZ PAS la mise à terre à conduit de gaz.
- N'INSTALLEZ PAS un fusible dans le circuit de mise à terre - ce qui peut causer une secousse électrique.
- Vérifiez avec un électricien certifié à ce que la hotte soit bien mise à terre.
- Faute de suivre ces recommandations pourrait occasionner un feu.

Uniquement pour usage menager.

TOOLS NEEDED FOR INSTALLATION

- Saber Saw or Jig Saw
- Drill
- 1 1/4" Wood Drill Bit
- Pliers
- Phillips Screwdriver
- Flat Blade Screwdriver
- Wire Stripper or Utility Knife
- Metal Snips
- Measuring Tape or Ruler
- Level
- Pencil
- Caulking Gun
- Duct Tape

PARTS SUPPLIED FOR INSTALLATION

- 1 Hardware Package
- 1 Literature Package

PARTS NEEDED FOR INSTALLATION

- 2 Conduit Connectors
- Power Supply Cable
- 1 Wall or Roof Cap
- All Metal Ductwork

OPTIONAL ACCESSORIES AVAILABLE

• ***Ductless Conversion Kit**

For non-vented installations only
 * it is highly recommended that professional style cooking always be vented to the outside part # 620000042 - Stainless

• **Replacement Charcoal Filter**

For non-vented installations only, replace charcoal filter as needed part # 620000041

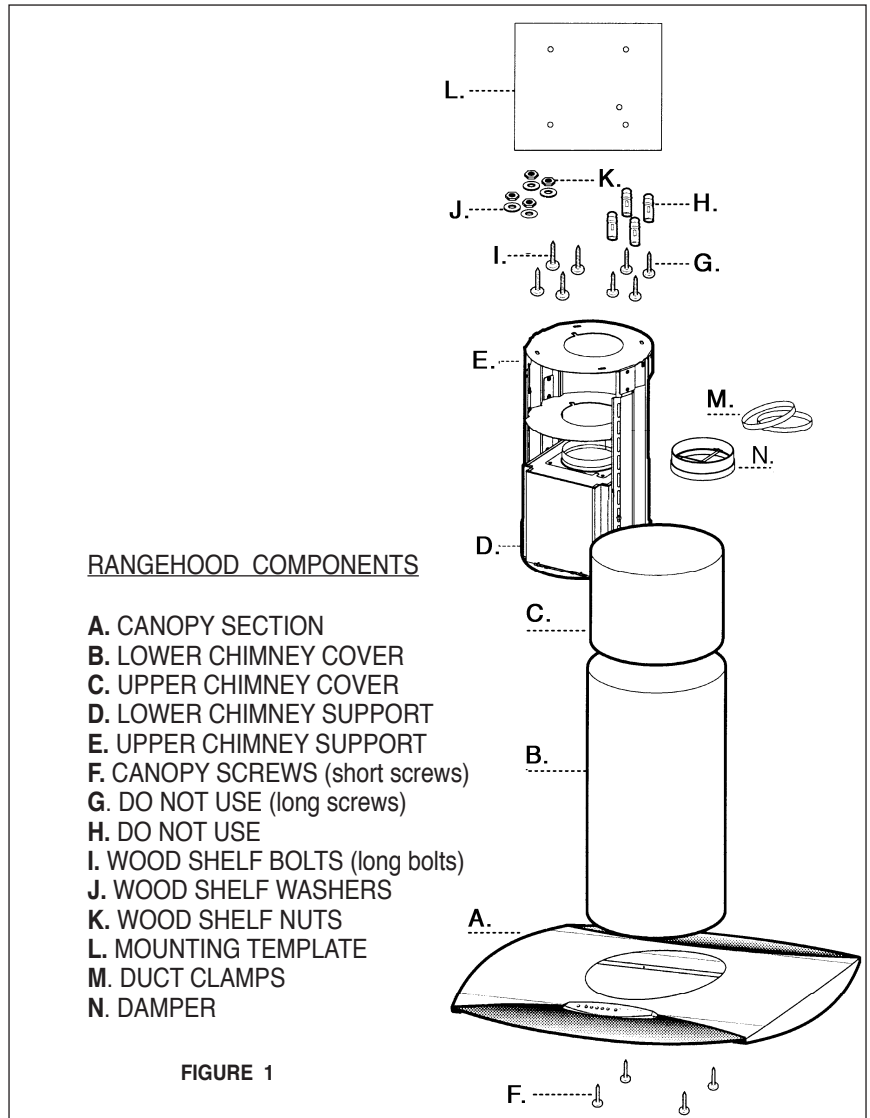

RANGEHOOD COMPONENTS

- A. CANOPY SECTION
- B. LOWER CHIMNEY COVER
- C. UPPER CHIMNEY COVER
- D. LOWER CHIMNEY SUPPORT
- E. UPPER CHIMNEY SUPPORT
- F. CANOPY SCREWS (short screws)
- G. DO NOT USE (long screws)
- H. DO NOT USE
- I. WOOD SHELF BOLTS (long bolts)
- J. WOOD SHELF WASHERS
- K. WOOD SHELF NUTS
- L. MOUNTING TEMPLATE
- M. DUCT CLAMPS
- N. DAMPER

FIGURE 1

UNPACK THE RANGEHOOD

Remove the rangehood from the carton and place on a flat surface for assembly. Before discarding the packaging, check to make sure that no mounting hardware or parts are missing. **DO NOT REMOVE THE PLASTIC COVERING ON THE CHIMNEYS AT THIS TIME!** This plastic covering protects the chimney from scratches during installation.

For safe packaging, the entire chimney section of the hood is shipped assembled. It must be disassembled completely for installation. Disassemble packaged chimney components by sliding apart the chimney covers (**B and C in FIGURE 1**). Remove the UPPER CHIMNEY COVER (**C**) from the UPPER CHIMNEY SUPPORT (**E**) by removing the 2 philips screws on the outside top of the chimney cover.

PREPARING TO ATTACH THE CHIMNEY

The rangehood attaches to the ceiling by a metal support structure (**D and E in FIGURE 1**). This support must be attached to the ceiling before the canopy is attached. This structure must be firmly attached to the ceiling.

FOR WOOD CEILINGS: Use four 4" long wood screws and washers.

FOR PLASTER OR SHEET ROCK CEILINGS: If possible, the support must be attached to the ceiling joists. If not, a supporting structure behind the sheet rock must be built.

FOR WOOD SHELVES: Use items I, J, & K in FIGURE 1.

CALCULATE THE DUCTRUN LENGTH

The ductrun should not exceed 35 equivalent feet if ducted with the required minimum of 6" round duct. Calculate the length of the ductwork by adding the equivalent feet in FIGURE 2 for each piece of duct in the system. An example is given in FIGURE 3.

45° Elbow	3.0 feet
90° Elbow	5.0 feet
90° Flat Elbow	12.0 feet
Wall Cap	0.0 feet

FIGURE 2

For best results, use no more than three 90° elbows. Make sure that there is a minimum of 24" of straight duct between elbows if more than one is used. Do not install two elbows together. If you must elbow right away, do it as far away from the hood's exhaust opening as possible.

9 Feet Straight Duct	9.0 feet
2 - 90° Elbows	10.0 feet
Wall Cap	0.0 feet
Total System	19.0 feet

FIGURE 3

PLAN THE INSTALLATION

This rangehood can be installed as either ducted or ductless. When installed ductless, the rangehood vents out of a grate on the back of the lower chimney. Ductless installations require a **Ductless Conversion Kit**, available from your dealer.

WARNING! BEFORE MAKING ANY CUTS OR HOLES FOR INSTALLATION, DETERMINE WHICH VENTING METHOD WILL BE USED AND CAREFULLY CALCULATE ALL MEASUREMENTS.

(vented to the outside) **DUCTED** INSTALLATION DIMENSIONS

The Axia Isola Plus chimney is highly adjustable and designed to meet varying ceiling heights as indicated in **FIGURE 4**. The chimney can be adjusted for ceilings between 7' 5 5/8" and 8' 10 5/8" depending on the distance between the bottom of the hood and the cooktop (distance **x** in **FIGURE 4**).

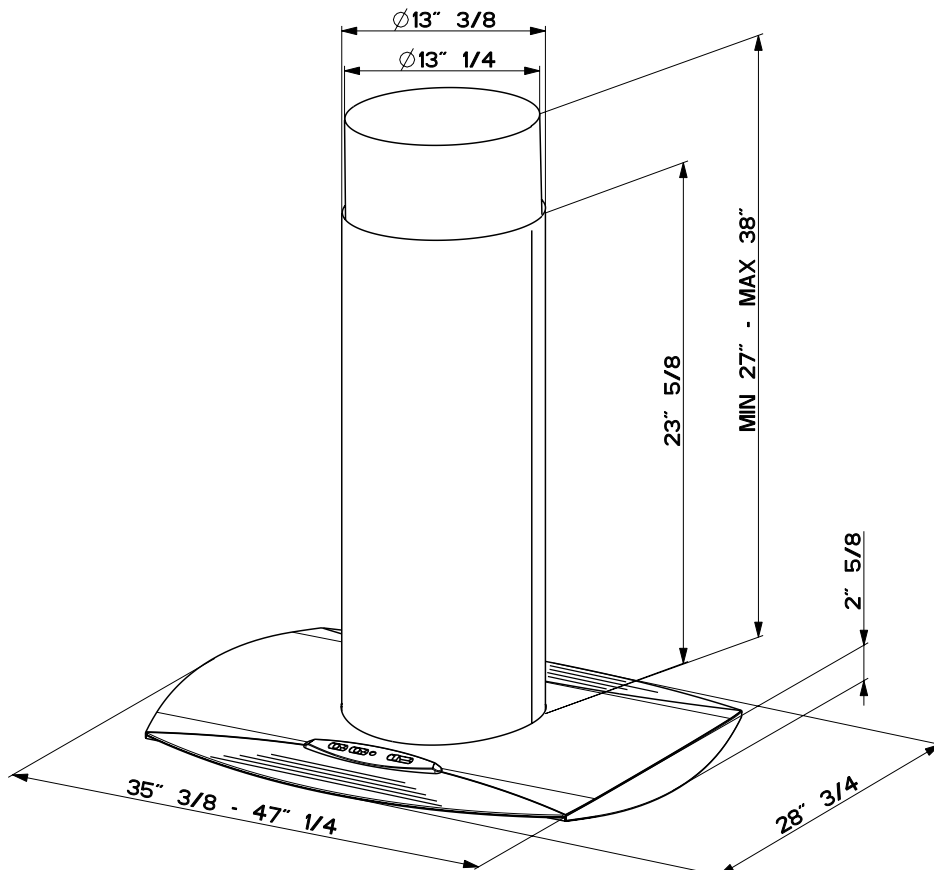
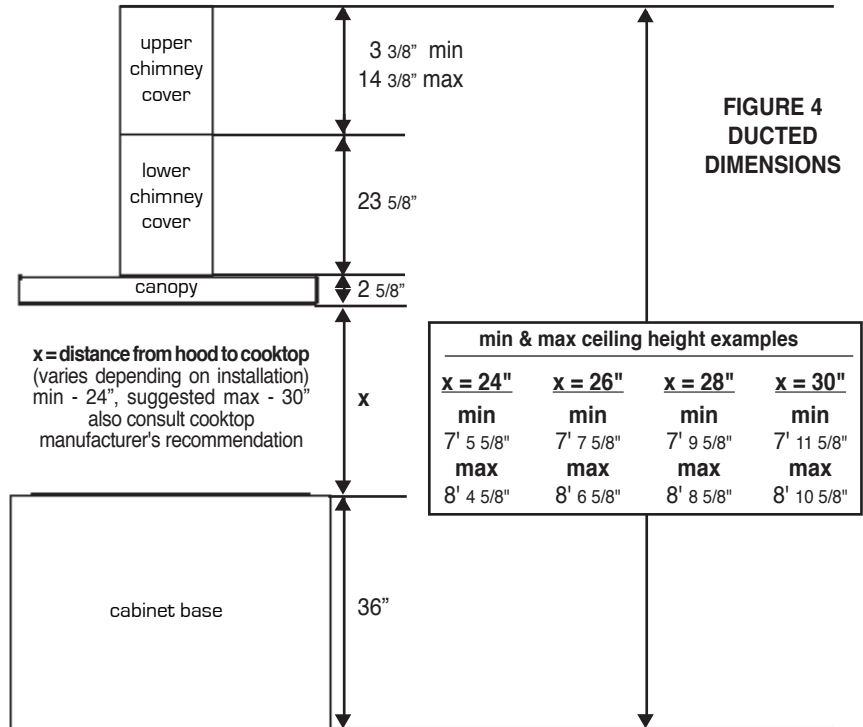

WARNING

DUE TO THE SIZE AND WEIGHT OF THIS RANGEHOOD, THE SUPPORT MUST BE FIRMLY ATTACHED TO THE CEILING. For plaster or sheet rock ceilings, the support must be attached to the joists. If this is not possible, a support structure must be built behind the plaster or sheet rock. The manufacturer assumes no responsibility for injury or damage caused by improper installations.

PLAN THE INSTALLATION

This rangehood can be installed as either ducted or ductless. When installed ductless, the rangehood vents out of a grate on the back of the lower chimney. Ductless installations require a **Ductless Conversion Kit**, available from your dealer.

WARNING! BEFORE MAKING ANY CUTS OR HOLES FOR INSTALLATION, DETERMINE WHICH VENTING METHOD WILL BE USED AND CAREFULLY CALCULATE ALL MEASUREMENTS.

(not vented to the outside) **DUCTLESS** INSTALLATION DIMENSIONS

The ductless Axia Isola Plus chimney is adjustable for varying ceiling heights as indicated in **FIGURE 5**. The chimney can be adjusted for ceilings between 7' 10 5/8" and 8' 10 5/8" depending on the distance between the bottom of the hood and the cooktop (**distance x** in **FIGURE 5**).

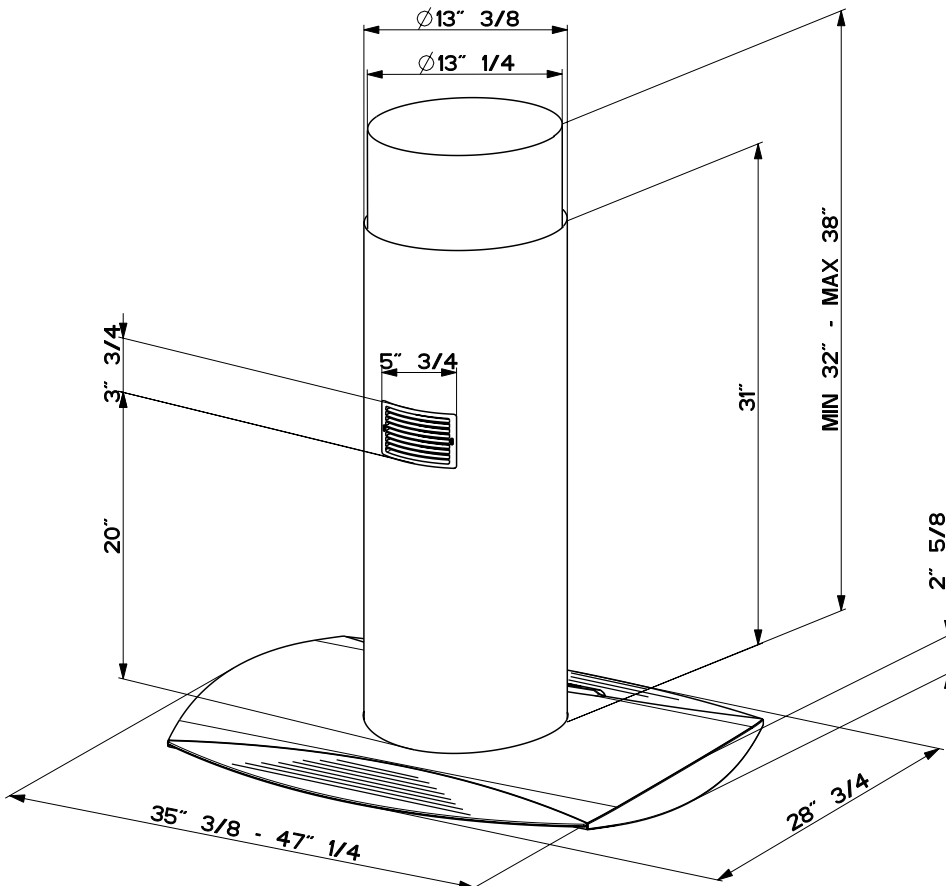
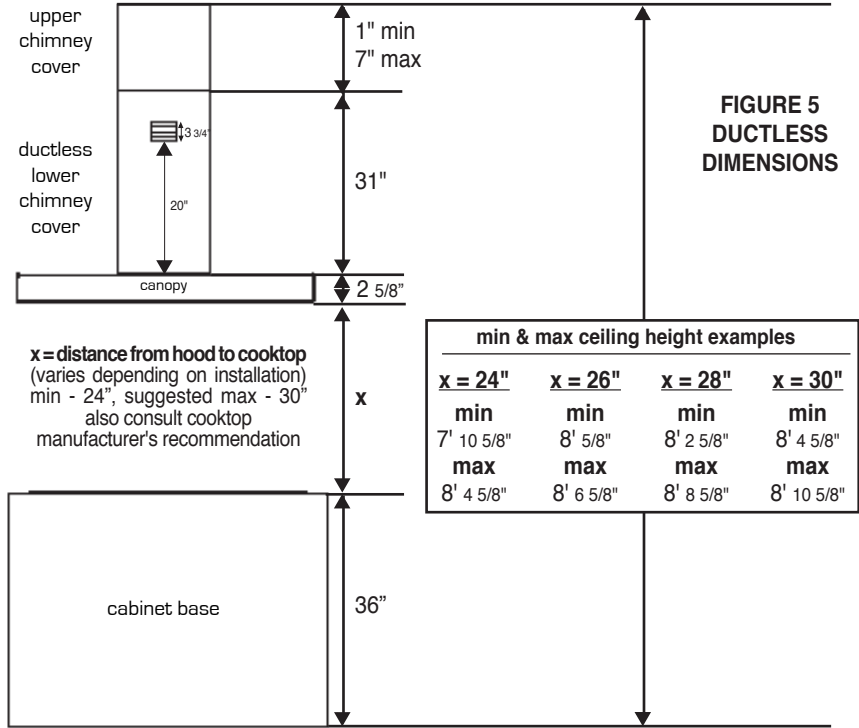

WARNING

DUE TO THE SIZE AND WEIGHT OF THIS RANGEHOOD, THE SUPPORT MUST BE FIRMLY ATTACHED TO THE CEILING. For plaster or sheet rock ceilings, the support must be attached to the joists. If this is not possible, a support structure must be built behind the plaster or sheet rock. The manufacturer assumes no responsibility for injury or damage caused by improper installations.

ATTACH THE SUPPORT

1. Put a thick, protective covering over cooktop, set-in range or countertop to protect from damage or dirt.

2. Determine and clearly mark with a pencil on the ceiling where the rangehood will be installed.

3. A template (L in FIGURE 6) for mounting the support is supplied in the carton with the support. Use this template to mark holes for support on the ceiling.

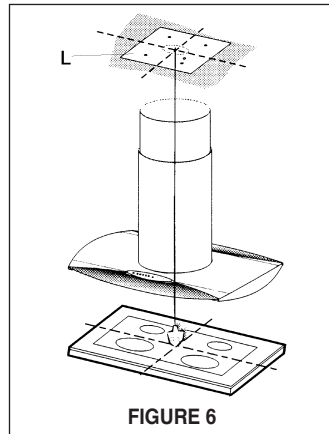

FIGURE 6

4. Determine and make necessary cuts for the ductwork. The duct opening is shown on the mounting template (L in FIGURE 6). Install ductwork before mounting the support.

IMPORTANT NOTE: BE CAREFUL WHEN DETERMINING THE LOCATION FOR THE HOLE IN YOUR CEILING FOR THE DUCT WORK. THIS HOLE SHOULD NOT BE CENTERED OVER THE CENTER OF THE COOKING SURFACE AS THE DUCT WORK THAT RUNS UP INSIDE THE CHIMNEY AND THROUGH THE CEILING IS NOT IN THE EXACT CENTER OF THE CHIMNEY.

5. Determine the proper location for the Power Supply Cable as indicated on the template. Use a 1 1/4" Drill Bit to make this hole. Run the Power Supply Cable. Use caulking to seal around the hole. **DO NOT turn on the power until installation is complete!** A knockout is provided at the top of the UPPER CHIMNEY SUPPORT (E in FIGURE 7).

6. For ducted installations, place the round DAMPER (A in FIGURE 7) into the exhaust opening of the rangehood and press down.

7. Before attaching the support to the ceiling, you must determine the desired length of the support structure and adjust the length of the support by removing the eight screws (indicated in FIGURE 7) with a flat head screwdriver. Once the length of the support is determined, install and tighten the eight screws.

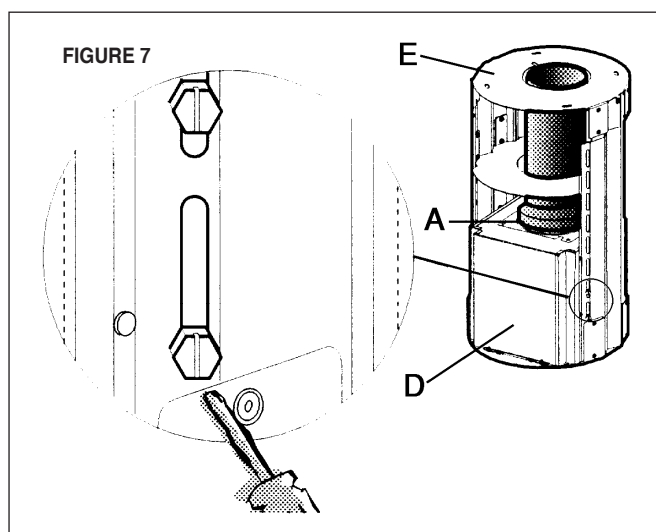

FIGURE 7

8. Slide the UPPER CHIMNEY COVER (C in FIGURE 1 for ducted installations - the upper chimney that came with the rangehood, or G in FIGURE 8 for ductless installations - the upper chimney that came with the ductless kit) down over the UPPER CHIMNEY SUPPORT (E in FIGURE 7) until it rests on the motor box (D in FIGURE 7). Attach the entire support to the ceiling. Make sure that the support is firmly attached to the ceiling.

FOR DUCTLESS INSTALLATIONS

Ductless installations require a **Ductless Conversion Kit** whose components are pictured in FIGURE 8. Do not use the DAMPER (A in FIGURE 7) for ductless installations. The LOWER CHIMNEY COVER (B in FIGURE 1) should be discarded and replaced by the new one with the hole from the **Ductless Conversion Kit** (F in FIGURE 8). The UPPER CHIMNEY COVER (C in FIGURE 1) should be discarded and replaced by the shorter one from the **Ductless Conversion Kit** (G in FIGURE 8).

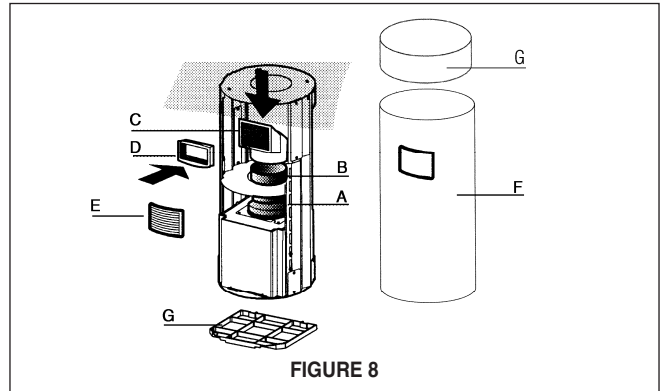

FIGURE 8

As indicated in FIGURE 8, place the FLANGE (A) into the exhaust opening of the rangehood and press down. Fit the DUCTLESS DIVERTER EXTENSION VERTICAL (B) over the FLANGE (A) and fit the DUCTLESS DIVERTER (C) over the EXTENSION (B). Fit the DUCTLESS DIVERTER EXTENSION HORIZONTAL (D) into the DIVERTER (C).

MAKE THE ELECTRICAL CONNECTION

Remove the cover from the field wiring compartment. **DO NOT turn on the power until installation is complete!** Connect the Power Supply Cable to the rangehood. Attach the White lead of the power supply to the White lead of the rangehood with a twist-on type wire connector. Attach the Black lead of the power supply to the Black lead of the rangehood with a twist-on type wire connector. Connect the Green (Green and Yellow) ground wire under the Green grounding screw.

INSTALLING THE RANGEHOOD

1. The UPPER CHIMNEY COVER (C in FIGURE 9) attaches using two screws provided (G in FIGURE 9). Slide up and attach the UPPER CHIMNEY COVER.

2. Attach the duct work to the DAMPER (A in FIGURE 7). Make sure to seal all joints with duct tape to prevent leaks.

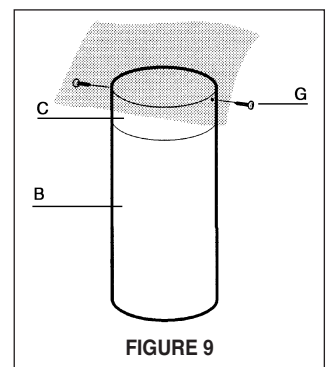

FIGURE 9

3. The LOWER CHIMNEY COVER (B in FIGURE 9) rests on the top of the CANOPY SECTION (A in FIGURE 1) once it is installed. Install the LOWER CHIMNEY COVER by sliding it up over the support.

For ductless installations, line up the DUCTLESS DIVERTER EXTENSION HORIZONTAL (D in FIGURE 8) with the hole in the LOWER CHIMNEY COVER (F in FIGURE 8) and snap in the VENT GRID (E in FIGURE 8).

⚠ WARNING

DUE TO THE SIZE AND WEIGHT OF THIS RANGEHOOD, THREE PEOPLE ARE REQUIRED TO INSTALL THE CANOPY. Two people must hold the canopy in place while the third person installs the screws that attach the canopy to the chimney. The manufacturer assumes no responsibility for injury or damage caused by improper installations.

4. From below, attach the CANOPY SECTION (A in FIGURE 10) to the assembled chimney support using the four screws provided (F in FIGURE 10).

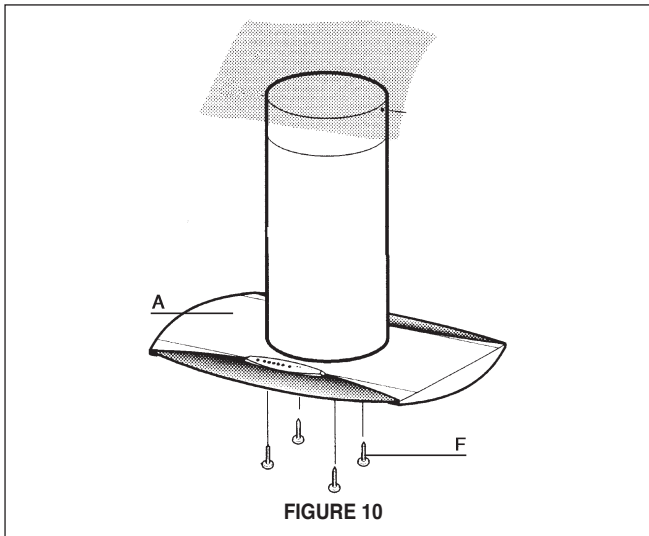

FIGURE 10

MAKE THE INTERNAL ELECTRICAL CONNECTIONS

5. Remove the metal brackets located on the top and bottom of the underside of the rangehood by removing the screws (FIGURE 11). Removing these brackets provides access to the control and lighting cables which must connect to the control and lighting cables from the inside of the chimney (FIGURE 12).

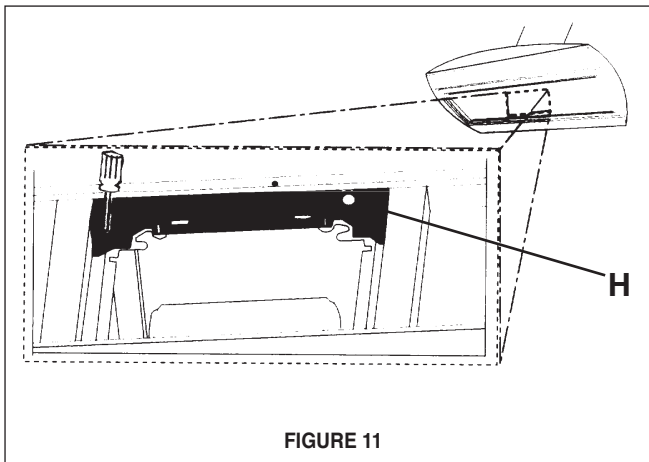

FIGURE 11

6. Run the control cable (A in FIGURE 12) from inside the chimney through the hole (H in FIGURE 11) in the appropriate bracket. Be sure to place the black rubber grommet around the cable inside the hole to protect the cable from being nicked by the metal hole. Connect the control cables together as indicated in FIGURE 12. Tuck them away under the brackets and reinstall the brackets. Repeat this process for the lighting cables (B in FIGURE 12).

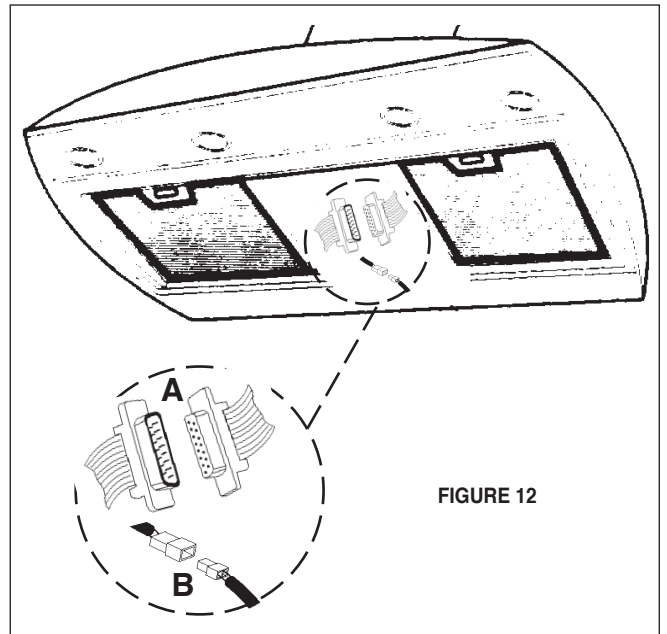

FIGURE 12

For ductless installations, install the CHARCOAL FILTER (G in FIGURE 8) behind the center grease filter opening by inserting and locking into place.

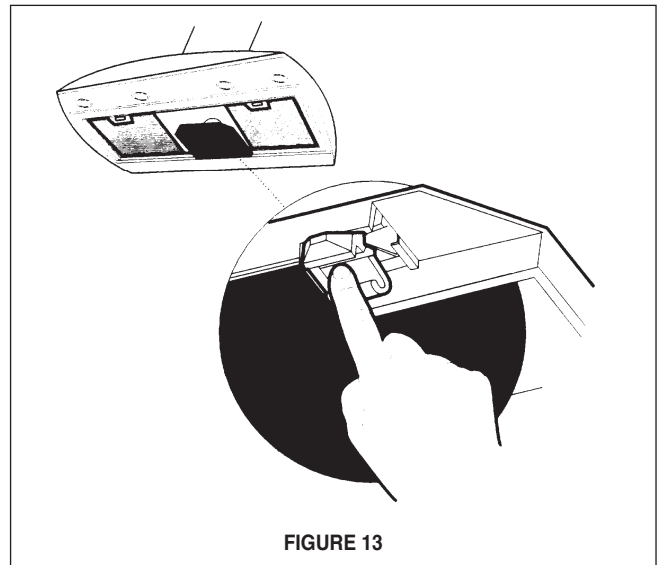

FIGURE 13

7. Install the grease filters using two hands by first pulling and turning the knob to the left so that the locking lever does not protrude from the filter (as in FIGURE 14). Insert the opposite end of the filter into the retaining channel. Insert the knob end next, then turn knob to the right to lock the filter into place.

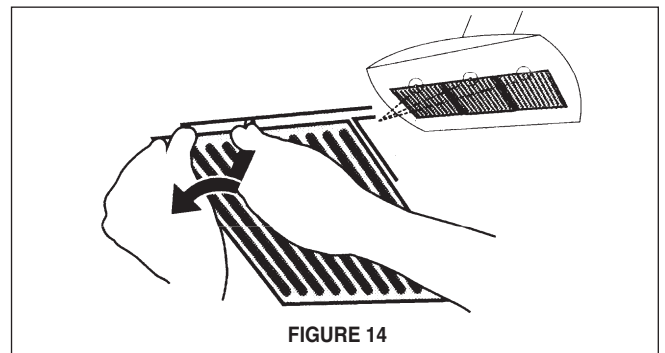

FIGURE 14

8. Turn the power supply on. Turn on blower and lights. If the rangehood does not operate, check that the circuit breaker is not tripped or the house fuse blown. If the unit still does not operate, disconnect the power supply and check that the wiring connections have been made properly.

WARRANTY & SERVICE

All Faber products are warranted against any defect in materials or workmanship for the original purchaser for a period of 1 year from the date of original purchase. This warranty covers labor and replacement parts. The warranty does not cover consumable parts such as filters and light bulbs. This warranty does not apply if this product has been subjected to faulty installation, misuse, or neglect. This warranty excludes any consequential expense or damage resulting from any use or malfunction of the product. All implied warranties are limited to the duration of this warranty.

To obtain warranty service, contact the dealer from whom you purchased the rangehood, or the local Faber distributor. If you cannot identify a local Faber distributor, contact us at (508) 358-5353 for the name of a distributor in your area.

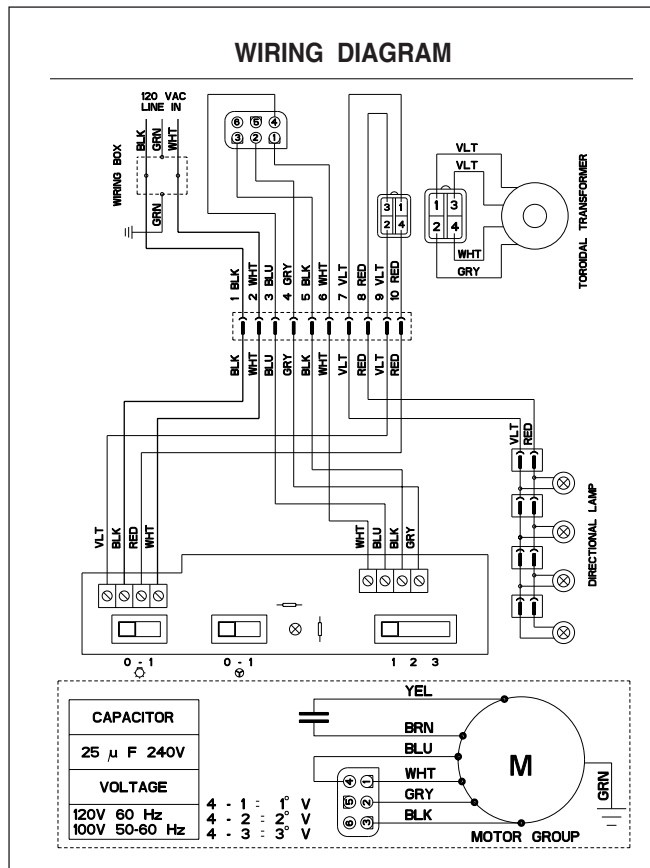

- This rangehood uses 20 watt halogen lamps.

USE AND CARE INFORMATION

This rangehood system is designed to remove smoke, cooking vapors and odors from the cooktop area.

Rangehood Control Panel

The control panel is located on top of the rangehood canopy. The position and function of each control button are indicated in **FIGURE 15**.

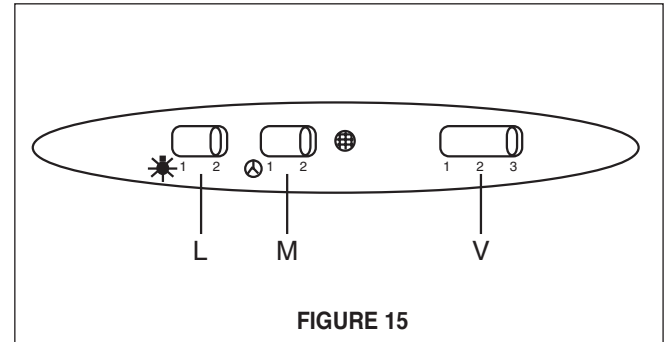

Light On/Off Button (L)

On/Off switch for the halogen light. Move the switch to "1" to turn the light ON and to "0" to turn it OFF.

Blower On/Off Button (M)

On/Off switch for the blower. Move the switch to "1" to turn the blower ON and to "0" to turn it OFF.

Blower Speed Button (V)

Speed control for blower. Moving the switch to the 1 Position turns the blower on LOW. Moving the switch to the 2 Position turns the blower on MEDIUM. Moving the switch to the 3 Position turns the blower on HIGH.

For Best Results

Start the rangehood several minutes before cooking to develop proper airflow. Allow the unit to operate for several minutes after cooking is complete to clear all smoke and odors from the kitchen.

Cleaning

The stainless steel grease filters should be cleaned frequently in hot detergent solution or washed in the dishwasher. Stainless steel cleaner should be used on stainless rangehoods. Abrasives and scouring agents can scratch stainless steel finishes and should not be used to clean finished surfaces.

Replacing the Lamps

Before attempting to replace the lamps, make sure that the light switch is turned off. Remove the 2 screws (as indicated in **FIGURE 16**) that hold the light support and gently pull the support down from the hood. Remove the lamp from the light support and replace with new lamp. Replace the light support and fix it into place with the 2 screws.

