

Installation Instructions / Warranty

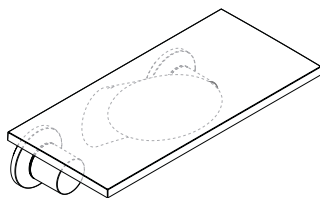

Axor Massaud
18112001

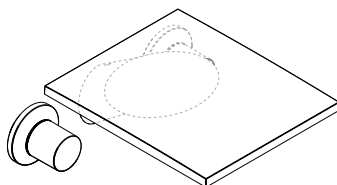

Axor Massaud
18115001

AXOR[®]
hansgrohe

Axor Massaud 3-Hole Lavatory Mixer Trim with Short Spout 18112001

Axor Massaud 3-Hole Lavatory Mixer Trim with Long Spout 18115001

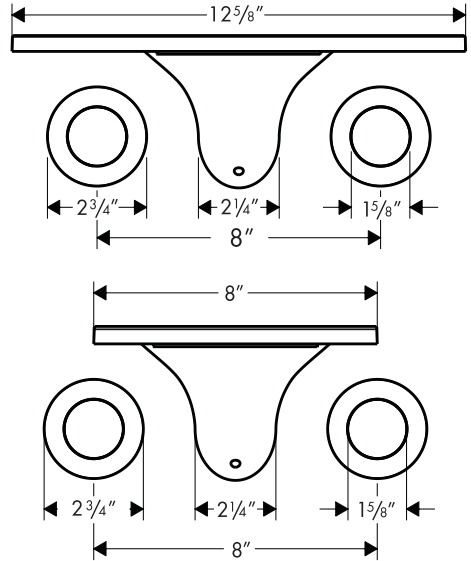
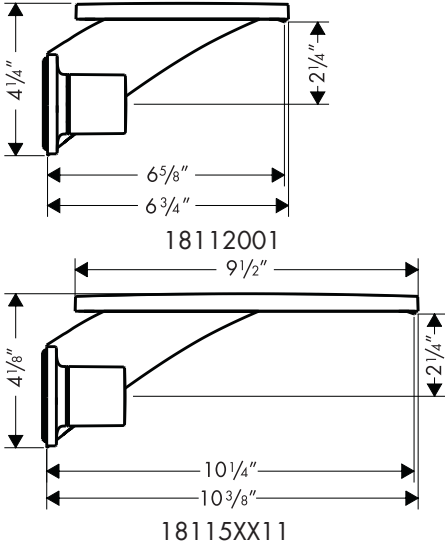

Product Specification

Max. Flow Rate	2.2 gpm
Max. incoming water pressure	145 psi
Recommended water pressure	14.5 - 72 psi
Max. hot water temperature	176° F*
Recommended hot water temp	120°F - 140°F*

No drain is included.

This unit can be used with continuous flow water heaters if the flow pressure is at least 20 psi.

This unit is listed by IAPMO.

*Know and follow all applicable local plumbing codes when setting the temperature on the water heater.

Installation Considerations

- Rough 18113181 (not included) must be installed. The finished wall surface (tile, etc.) must be installed, and the wall made watertight prior to installation of this faucet.
- Do not place more than 8 lbs on the spout.
- Prolonged exposure to residues from soap, shampoo, toiletries, or cosmetics can damage the finish. Such damage is not covered by the Hansgrohe warranty.

Installation

Remove the caps from the plaster shields on the rough valve (1).

Cut the plaster shields so that they extend $1/16''$ outside the surface of the finished wall (2).



Seal the wall around the plaster shields with waterproof sealant.



Failure to seal the wall can lead to possible water damage.

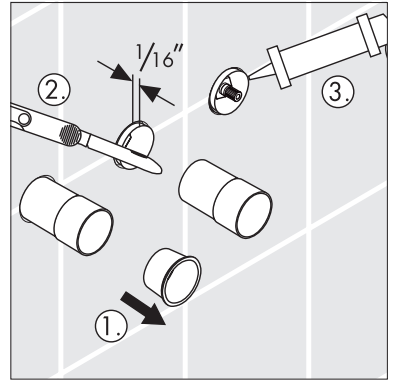

Remove the plug from the spout outlet using a 17 mm socket wrench (1).

Install the valve slip coupling on one of the valves (2).

Mark a point on the slip coupling $3/16''$ from the surface of the finished wall. Cut the slip coupling at that point (3).

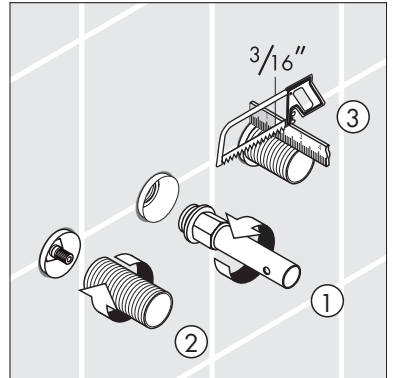

Install the spindle extension (1).

Mark a point on the spindle extension $9/16''$ from the surface of the finished wall. Cut the spindle extension at that point (2).

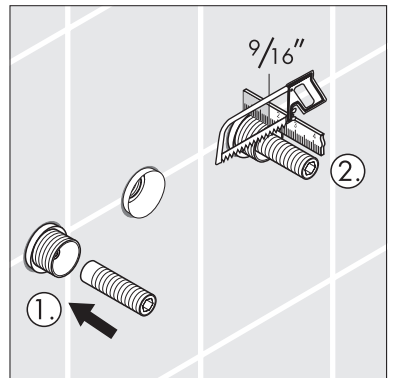

Insert a measuring device in the spout outlet. Measure from the port on the rough to the end of the plaster shield. Record this measurement (X). Add 2" to X. Cut the spout connector so that it is $X + 2"$ long.

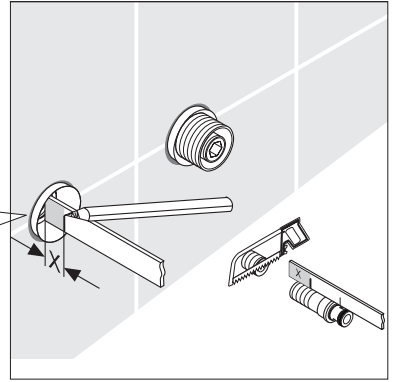
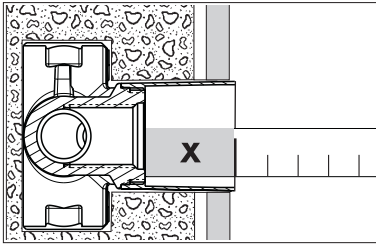

Wrap the threads on the spout connector with Teflon thread tape (1).

Screw the spout connector into the spout port with a 12 mm Allen wrench (not included) (2). The spout connector should extend $1 \frac{3}{16}"$ outside the surface of the finished wall.

Install the handle sealing rings, escutcheons, nuts, snap connectors and screws, and color rings (3). The blue color ring should be on the right, the red color ring on the left.

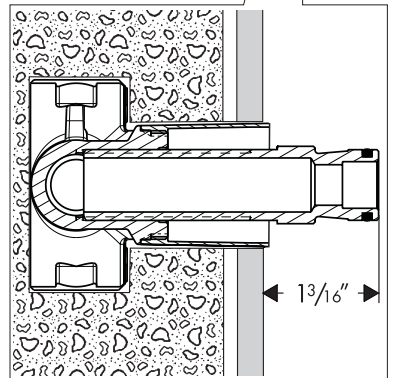
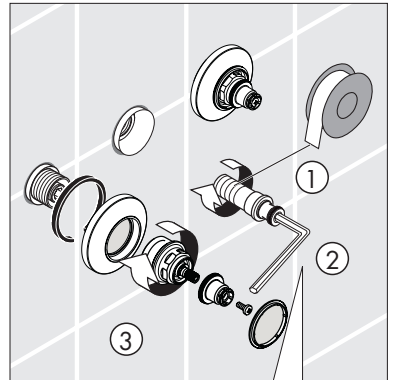

Make sure that the snap connectors are firmly screwed to the nuts.

Place the handles over the snap connectors and press very firmly into place.

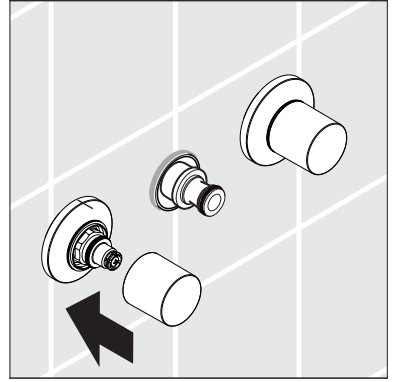

Position the spout adapter and seal over the spout connector.

Secure the adapter to the rough with the screws.

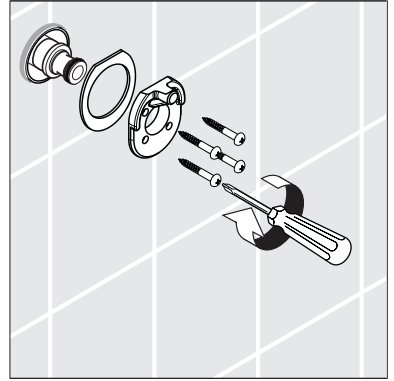

Slide the spout into place over the adapter and connector (1).

Tighten the top set screw with a 3 mm Allen wrench (included) (2).

Tighten the bottom set screw (3).

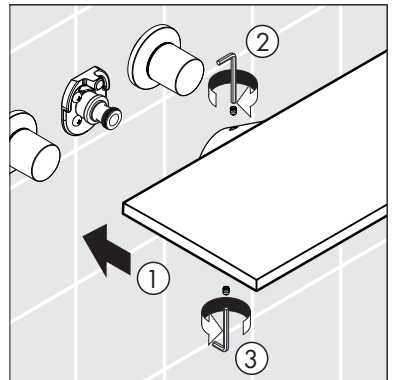

Replacement Parts

18112001

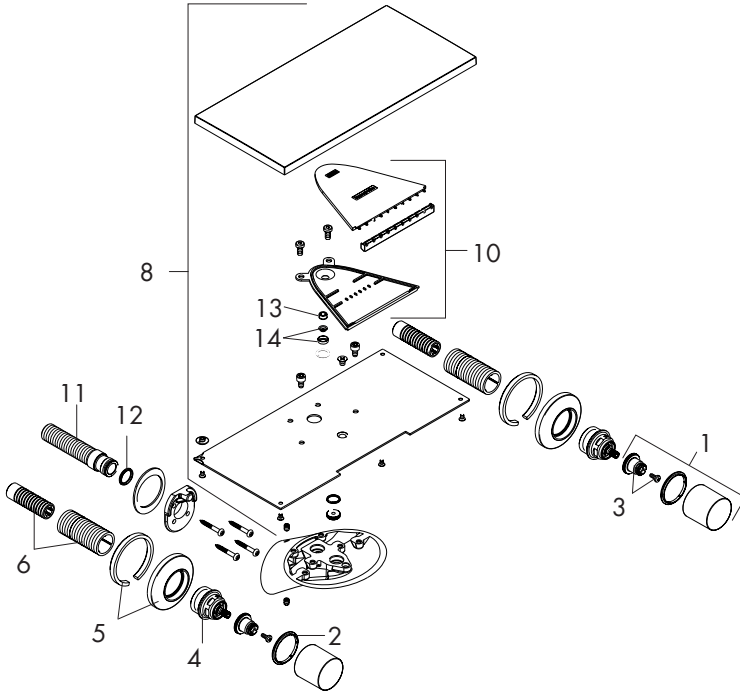

1	handle	18098000
2	color ring set	98698000
3	snap connector	94184000
4	nut	98677000
5	handle escutcheon	98697000
6	fixing set	96392000
7	spout	98700000
8	spout	98658000
9	spray former	97448000
10	spray former	97446000
11	spout connector	97228000
12	16 x 2.5 o-ring	98134000
13	flow limiter	13968000
14	filter	98516000

18115001

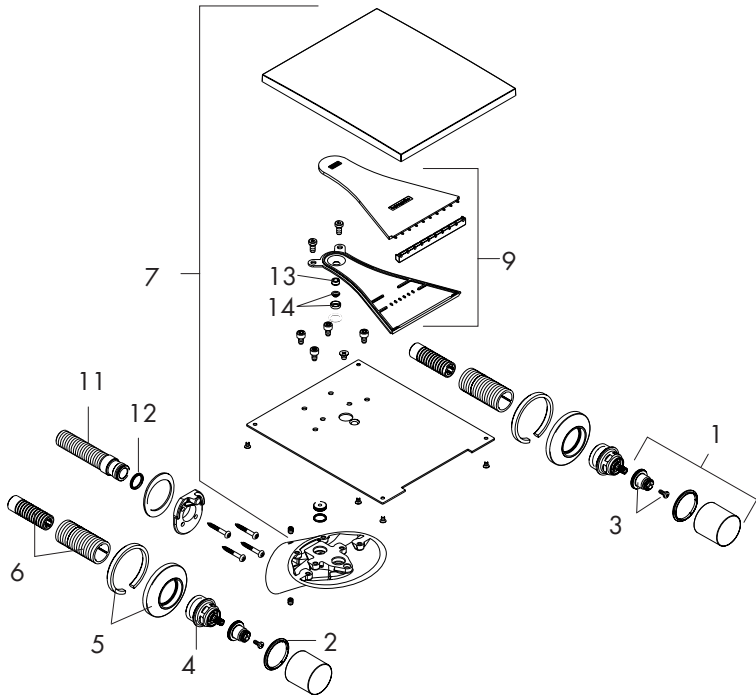

Cleaning Recommendation for Hansgrohe Products

Modern lavatory faucets, kitchen faucets, and showers consist of very different materials to comply with the needs of the market with regard to design and functionality. To avoid damage and returns, it is necessary to consider certain criteria when cleaning.

Cleaning Materials for Faucets and Showers

Acids are a necessary ingredient of cleaning materials for removing lime, however please pay attention to the following points when cleaning faucets and showers:

- Only use cleaning materials which are explicitly intended for this type of application.
- Never use cleaning materials which contain hydrochloric, formic, phosphoric, or acetic acid, as they cause considerable damage.
- Never mix one cleaning material with another.
- Never use cleaning materials or appliances with an abrasive effect, such as unsuitable cleaning powders, sponge pads, or micro fiber cloths.

Cleaning Instructions for Faucets and Showers

Please follow the cleaning material manufacturer's instructions. In addition, pay attention to the following points:

- Clean the faucets and showers as and when required
- Use the amount of cleaning product and the amount of time recommended by the manufacturer. Do not leave the cleaner on the fixture longer than necessary.
- Regular cleaning can prevent calcification.
- When using spray cleaners, spray first onto a soft cloth or sponge. Never spray directly onto the faucet as droplets can enter openings and gaps and cause damage.
- After cleaning, rinse thoroughly with clean water to remove any cleaner residue.

Important

Residues of liquid soaps, shampoos, and shower foams can also cause damage, so rinse with clean water after using.

Please note: if the surface is already damaged, the effect of cleaning materials will cause further damage.

Components with damaged surfaces must be replaced or injury could result.

Damage caused by improper treatment is not covered under the warranty.

Limited Lifetime Consumer Warranty

This product has been manufactured and tested to the highest quality standards by Hansgrohe, Inc. ("Hansgrohe"). This warranty is limited to Hansgrohe products which are purchased by a consumer in the United States after March 1, 1996, and installed in either the United States or Canada.

WHO IS COVERED BY THE WARRANTY

This warranty extends to the original consumer purchaser only. This warranty is non-transferable.

WHAT IS COVERED BY THE WARRANTY

This warranty covers only your Hansgrohe manufactured product. Hansgrohe warrants this product against defects in material or workmanship as follows: Hansgrohe will repair at no charge for parts only or, at its option, replace any product or part of the product that proves defective because of improper workmanship and/or material, under normal installation, use, service and maintenance. If Hansgrohe is unable to provide a replacement and repair is not practical or cannot be timely made, Hansgrohe may elect to refund the purchase price in exchange for the return of the product.

LENGTH OF WARRANTY

Replacement or repaired parts of products will be covered for the term of this warranty as stated in the following two sentences. If you are a consumer who purchased the product for use primarily for personal, family, or household purposes, this warranty extends for as long as you own the product and the home in which the product is originally installed. If you purchased the product for use primarily for any other purpose, including, without limitation, a commercial purpose, this warranty extends only (i) for 1 year, with respect to Hansgrohe and Commercial products, and (ii) for 5 years, with respect to AXOR products.

THIS WARRANTY DOES NOT COVER, AND HANSGROHE WILL NOT PAY FOR:

- A. Conditions, malfunctions or damage not resulting from defects in material or workmanship.
- B. Conditions, malfunctions or damage resulting from (1) normal wear and tear, improper installation, improper maintenance, misuse, abuse, negligence, accident or alteration, or (2) the use of abrasive or caustic cleaning agents or "no-rinse" cleaning products, or the use of the product in any manner contrary to the product instructions. (3) Conditions in the home such as excessive water pressure or corrosion.
- C. Labor or other expenses for the disconnection, deinstallation, or return of the product for warranty service, or for installation or reinstallation of the product (including but not limited to proper packaging and shipping costs), or for installation or reinstallation of the product.
- D. Accessories, connected materials and products, or related products not manufactured by Hansgrohe.

TO OBTAIN WARRANTY PARTS OR INFORMATION

Contact your Hansgrohe retailer, or contact Technical Service at:

Hansgrohe Inc.
1492 Bluegrass Lakes Parkway
Alpharetta GA 30004
Toll-free (800) 334-0455.

In requesting warranty service, you will need to provide

1. The sales receipt or other evidence of the date and place of purchase.
2. A description of the problem.
3. Delivery of the product or the defective part, postage prepaid and carefully packed and insured, to Hansgrohe Inc. 1492 Bluegrass Lakes Parkway, Alpharetta, Georgia 30004, Attention: Technical Service, if required by Hansgrohe.

When warranty service is completed, any repaired or replacement product or part will be returned to you postage prepaid.

EXCLUSIONS AND LIMITATIONS

REPAIR OR REPLACEMENT (OR, IN LIMITED CIRCUMSTANCES, REFUND OF THE PURCHASE PRICE) AS PROVIDED UNDER THIS WARRANTY IS THE EXCLUSIVE REMEDY OF THE PURCHASER. HANSGROHE NEITHER ASSUMES NOR AUTHORIZES ANY PERSON TO CREATE FOR IT ANY OBLIGATION OR LIABILITY IN CONNECTION WITH THIS PRODUCT.

HANSGROHE SHALL NOT BE LIABLE TO PURCHASER OR ANY PERSON FOR ANY INCIDENTAL, SPECIAL, OR CONSEQUENTIAL DAMAGES, ARISING OUT OF BREACH OF THIS WARRANTY OR ANY IMPLIED WARRANTY (INCLUDING MERCHANTABILITY).

Some States do not allow the exclusion or limitation of incidental or consequential damages, so the above limitation or exclusion may not apply to you. This warranty gives you specific legal rights, and you may have other rights which vary from State to State. You may be required by law to give us a reasonable opportunity to correct or cure any failure to comply before you can bring any action in court against us under the Magnuson-Moss Warranty Act.

PRODUCT INSTRUCTIONS AND QUESTIONS

Upon purchase or prior to installation, please carefully inspect your Hansgrohe product for any damage or visible defect. Prior to installing, always carefully study the enclosed instructions on the proper installation and the care and maintenance of the product. If you have questions at any time about the use, installation, or performance of your Hansgrohe product, or this warranty, please call or write to us or call us toll-free at 800 334 0455.

hansgrohe

Hansgrohe, Inc. • 1490 Bluegrass Lakes Parkway • Alpharetta, GA 30004
Tel. 770 360-9880 • Fax 770 360 9887

www.hansgrohe-USA.com