

# Office Pro 60

<b>Cooling Capacity</b>	Btu/hr. @ 95°	
	At 60% Relative Humidity	59,500
<b>Dimensions</b>	Width (Inches)	30
	Depth (Inches)	52
	Height (Inches)	64
	Weight (Pounds)	625
	Shipping Weight	755
<b>Electrical Characteristics</b>	Power Supply (Volts)	208/230/1
	Power Consumption (Kilowatts)	7.1
	Current Consumption (Amperes)	33
	Fuse Size (Amperes)	50
	NEMA Plug Configuration	6-50
	Min-max Voltage	195-250 Volt
	Power Cord Gauge	6AWG (3 Core)
	Power Cord Length (Feet)	6
<b>Compressor Characteristics</b>	Compressor Type	Hermetic Scroll
	R 22 Charge (Pounds)	6.83
	Operating Conditions: Min-max °F	65°-105°F, 50% RH
<b>Fan Characteristics</b>	<b>Evaporator:</b>	
	Fan Type	Centrifugal
	Air Flow (CFM) High/Low	1940/1770
	Max. External Static Pressure (Inches Of Water Gauge)	0.9
	<b>Condenser:</b>	
	Fan Type	Centrifugal
	Air Flow (CFM) High/Low	2830/2650
	Max. External Static Pressure (Inches Of Water Gauge)	0.85
<b>Safety Devices</b>	Compressor Overload Relay	Yes
	Fan Motor Protection	Yes
	Anti-freeze Thermostat	Yes
	Automatic Tank Shut-off	N/A
	Condensate Tank Capacity (Gallons)	Auto Pump Included
	High-pressure Switch	Yes
	Compressor Short-cycle Protection	Yes
	Fan Mode Switch	Yes
	Automatic Restart	Yes
	Thermostat	Yes
	Control Panel	Programmable
Thermostat Control	Electronic	
<b>Miscellaneous Features</b>	Operating Cost	\$0.504
	Humidity Removed @ 60% RH	1.97
	Accommodates Condensate Pump	Included
	Sound Level (Db) High/Low	69/67
	Max Evaporator Ducting Length*(Ft.)	40
	Max Condenser Ducting Length*(Ft.)	100

*\*subtract 10 Ft. For Every 90° Bend*

**800.367.8675 • www.spot-coolers.com**

Copyright © 2004 Spot Coolers, Inc. All rights reserved.

Spot Coolers

# Office Pro 60

**Power Supply** 208/230 volts 60 hertz 1 phase 33 amperes

**Width** 30 inches

**Depth** 52 inches

**Height** 64 inches

**Weight** (net/shipping) lbs 625/755

All models are backed by a 12-month warranty with 36 months for the compressor.

All coils are treated with an acrylic resin coating for extended life and corrosion resistance.

**TOP**

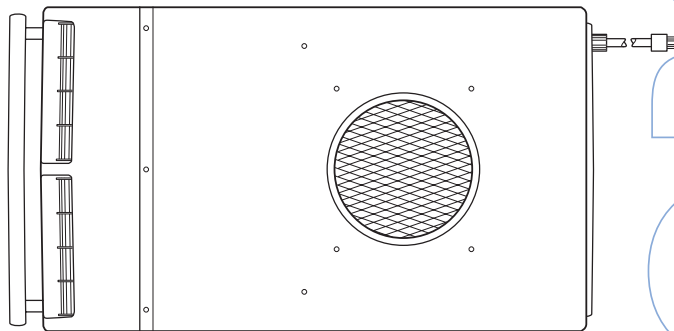

**FRONT**

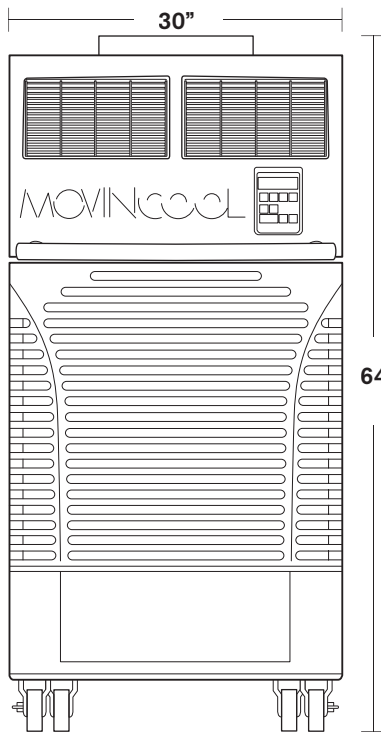

**SIDE**

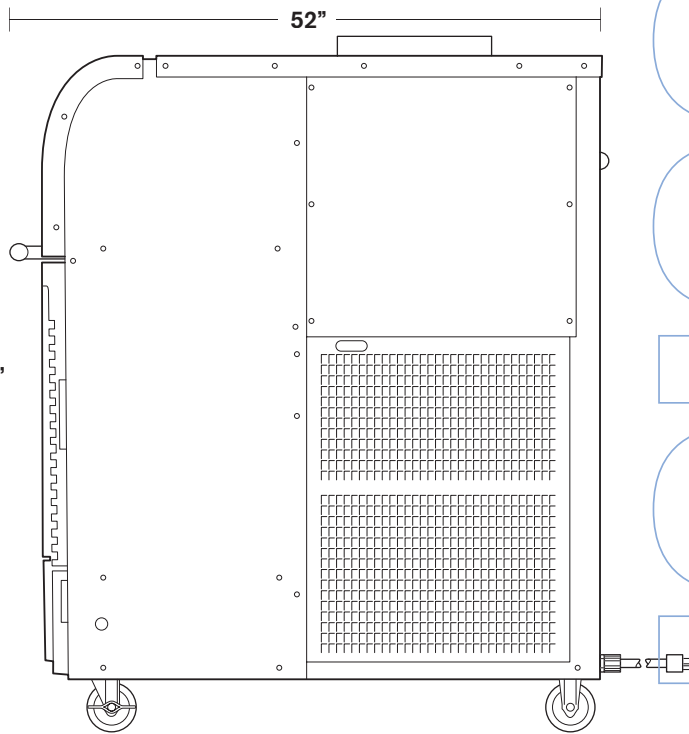

Spot Coolers

# Office Pro 60

## Accessories

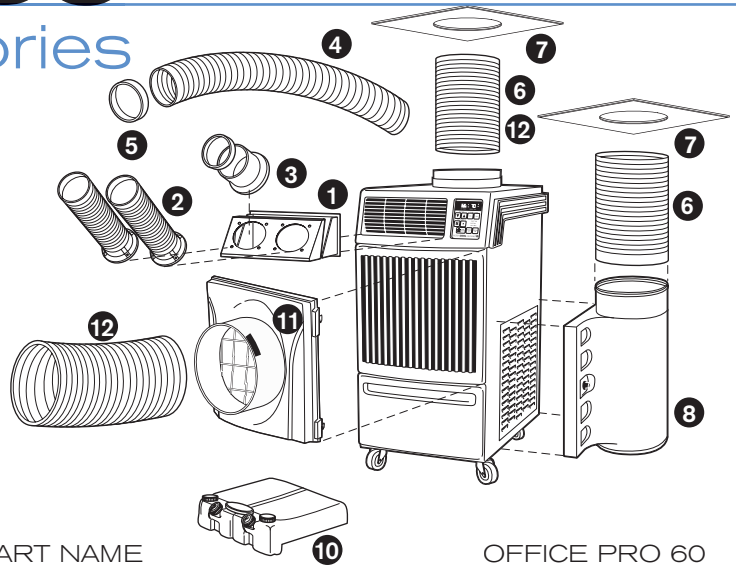

### AUTO CONDENSATE REMOVAL

#### PART NAME

#### OFFICE PRO 60

##### Condensate Pump Kit

220V pump includes 3/8" diameter x 20' length of hose.

**Included**

##### Condensate Tank

Drain tank storage for condensation. Requires condensate float, sold separately.

**OP60-10**

### CONDENSER AIR REMOVAL

Removing exhaust is easy. Simply replace the existing ceiling tile with ceiling tile accessory and 16" flexible hose. That's it!

##### Warm Air Flexible Duct

16" diameter wire-reinforced, accordion-style duct in 7' length for condenser exhaust or evaporator intake. Includes clamp.

**OP60-6**

##### Ceiling Tile

24" x 24" white tile with 16" hole for warm air duct.

**OP60-7**

### MAKE-UP AIR

When balanced air flow is required, attach the air plenum with a duct from the side of the unit to an outside air source. The air to the condenser is pulled from outside the room to eliminate problems associated with negative air pressure.

##### Air Duct

16" diameter wire-reinforced, accordion-style duct in 25' lengths for condenser exhaust or evaporator intake. Includes clamp.

**OP60-6, 12**

##### Ceiling Tile

24" x 24" white tile with 16" hole for warm air duct.

**OP60-7**

##### Condenser Air Plenum

White plastic plenum for return air to condenser. Hinged for filter cleaning.

**OP60-8**

### SPOT or REMOTE COOLING

To use the Office Pro to spot cool specific areas, use the nozzle adapter in place of the standard louvers. Attach cold air ducts to the adapter to cool remote hot spots. Trim rings give a finished look and keep the ducts from unraveling. To improve efficiency, use the evaporator air plenum to recirculate cool air.

##### Nozzle Adapter Kit

Two-piece metal frame converts air-flow from louvers to four 6" nozzles or two 8" cold air ducts. Includes mounting screws.

**OP60-1**

##### Nozzle Kit

6" diameter white plastic ducts that extend up to 3.5' in length. Includes flange, mounting screws and trim ring.

**OP60-2**

##### Cold Air Flange Kit

6" diameter gray metal flange with wire clamp and mounting screws. Use with cold air ducts.

**OP60-3**

##### Cold Air Self-Supported Duct

6" or 8" adjustable diameter white polypropylene duct that extends from 6.5' to 10' in length.

**OP60-4**

##### Cold Air Flexible Duct

8" diameter wire reinforced, accordion-style duct in 25' lengths (not shown).

**OP60-4A**

##### Trim Ring

6" diameter black end-cap for cold air self-supported duct.

**OP60-5**

##### Evaporator Air Plenum

White plastic plenum for return air to evaporator.

**OP60-11**

**800.367.8675 • www.spot-coolers.com**

Copyright © 2004 Spot Coolers, Inc. All rights reserved.

# Office Pro 60

## Construction Diagram

All models are backed by a 12-month warranty with 36 months for the compressor.

All coils are treated with an acrylic resin coating for extended life and corrosion resistance.

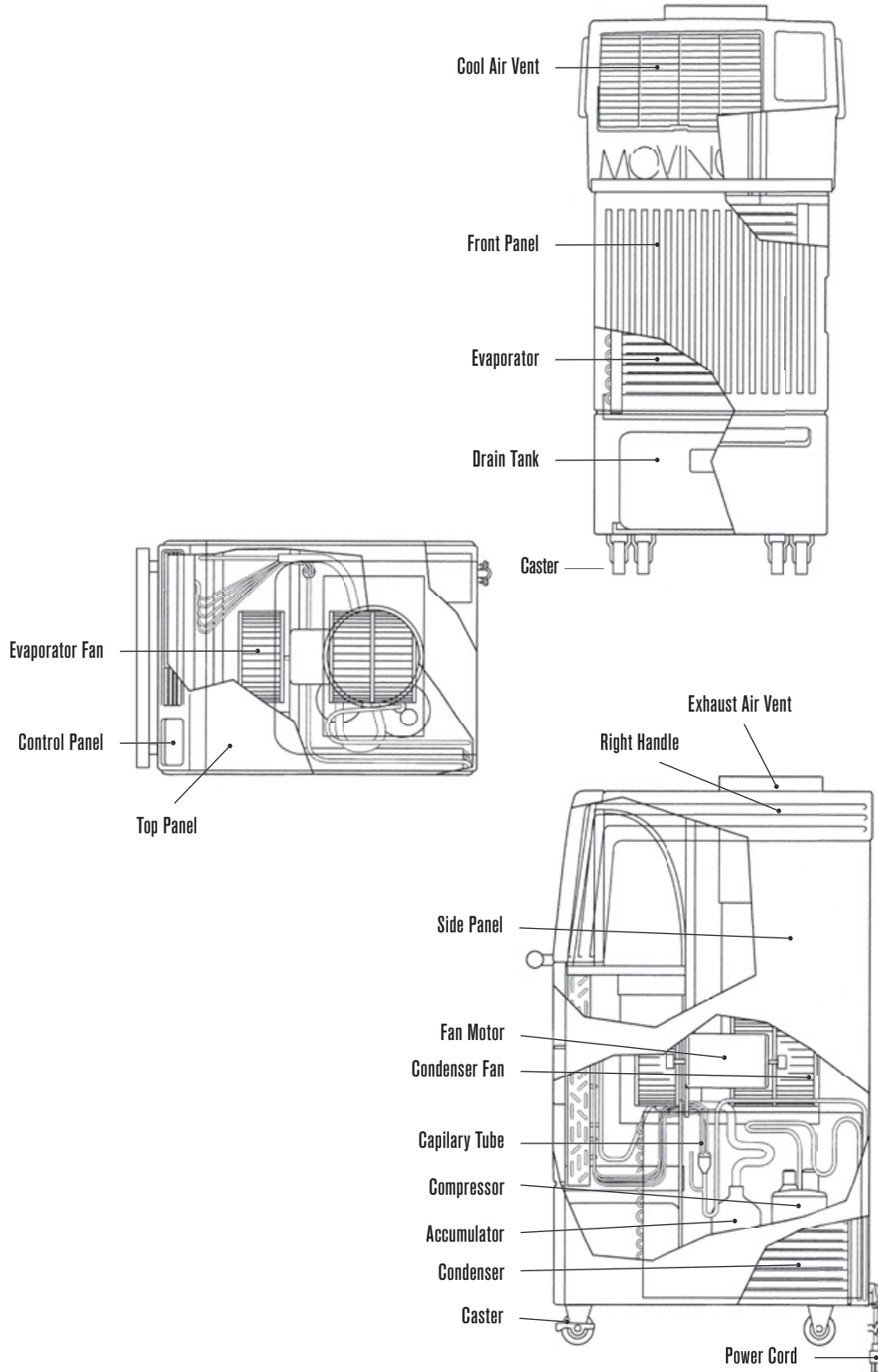

SPOT COOLERS