

Drink Caddy Assembly

The drink caddy is an accessory that is easy to assemble and install. This accessory helps keep beverages in a convenient position so it is easier to grab while maximizing shelf space.

The drink caddy is compatible with Zephyr 15" and 24" Compact Beverage Coolers. Please follow the instructions below to assemble and install the drink caddy.

1. There are slots shown in (A) and (B) that are present on each end of the drink caddy rows (1) and rails (2).
2. Thread the drink caddy rows (1) and rails (2) onto the frame (3) through the (A) & (B) slots.
3. Alternate the installation of the drink caddy rows and rails.
4. To remove each component from the frame, carefully pull each component apart by shimmying the pieces.

NOTE: To accommodate larger diameter beverage containers, remove a drink caddy row.

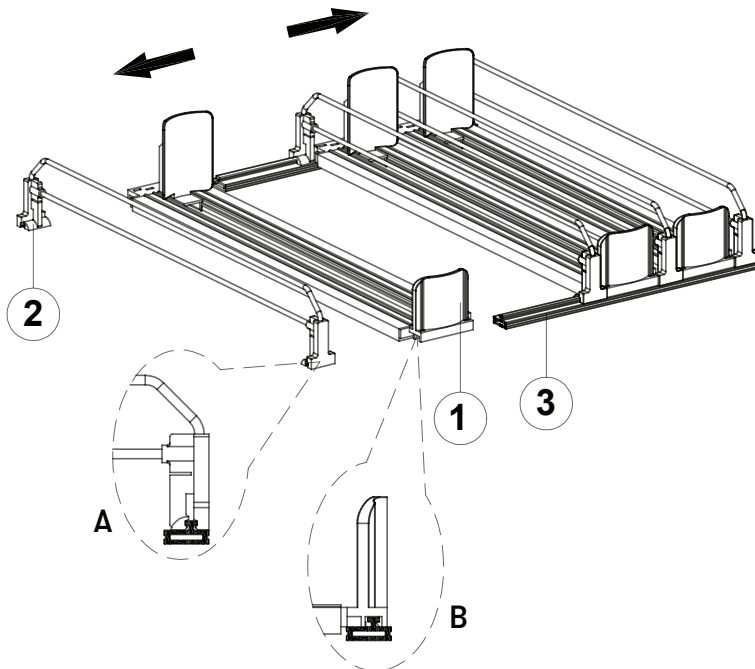

Dimensions

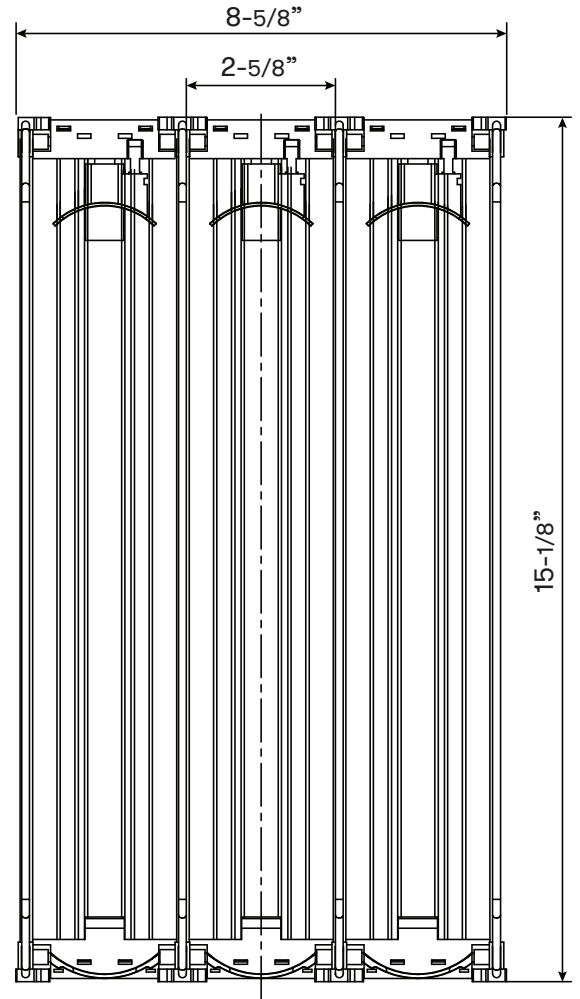

TOP VIEW

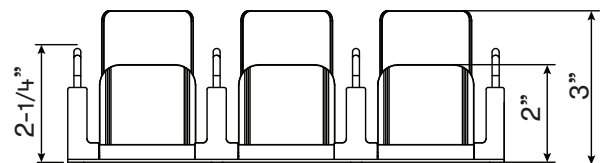

FRONT VIEW

Installation Instructions

Drink Caddy Installation

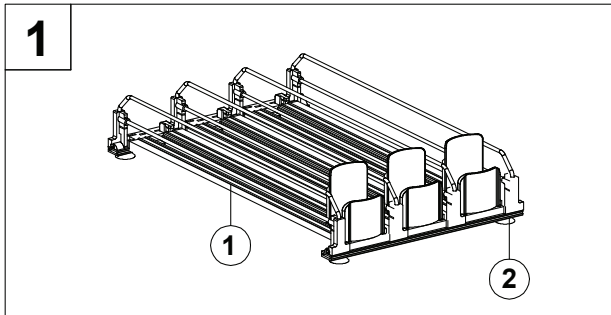

1. 4 suction cups (2) are present at the bottom of the drink caddy (1).

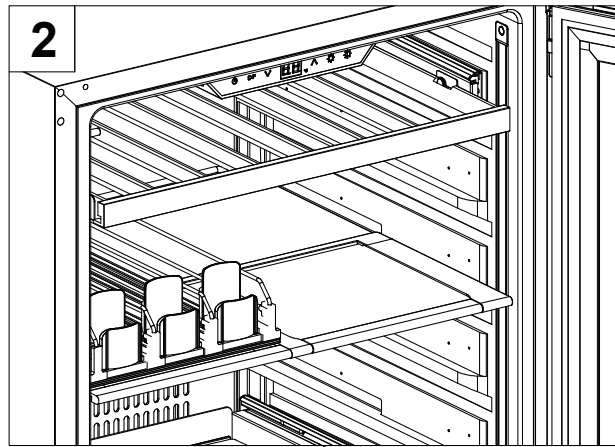

2. Place the drink caddy (1) onto the glass shelf (3) and press gently against the glass shelf to adhere the drink caddy.

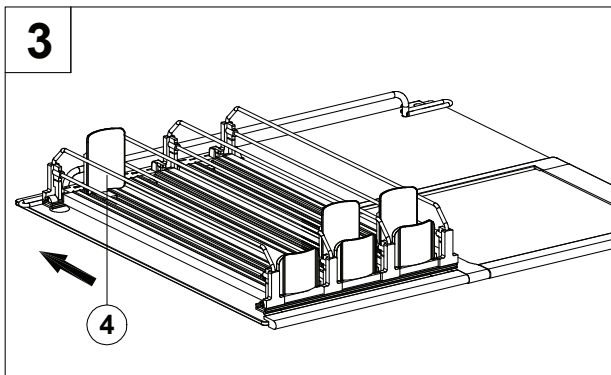

3. Push the push plate (4) to the back of the drink caddy to lock it.

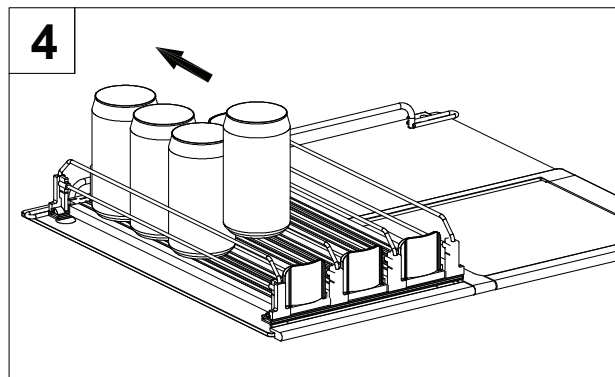

4. Place the beverages onto the drink caddy.

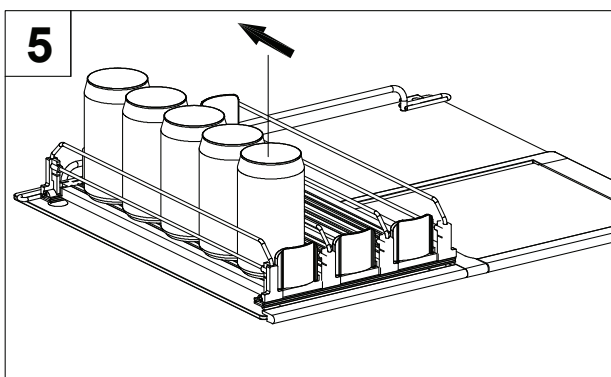

5. Carefully push the front beverage in the front against all the other beverages to unlock the push plate, allowing the beverages to slide forward.

TO OBTAIN SERVICE UNDER WARRANTY OR FOR ANY SERVICE RELATED QUESTIONS

United States Customers please call: 1-888-880-8368 or contact us at: zephyronline.com/contact

Canada Customers please call: 1-800-361-0799 or Email: service@distinctive-online.com

Zephyr Ventilation, LLC (referred to herein as “we” or “us”) warrants to the original consumer purchaser (referred to herein as “you” or “your”) of Zephyr products (the “Products”) that such Products will be free from defects in materials or workmanship as follows:

One Year Limited Warranty for Parts: For one year from the date of your original purchase of the Products, we will provide, free of charge, Products or parts to replace those that failed due to manufacturing defects subject to the exclusions and limitations below. We may choose, in our sole discretion, to repair or replace parts before we elect to replace the Products.

To Obtain Service Under Limited Warranty: To qualify for warranty service, you must: (a) notify us at the address or telephone number stated below within 60 days of the discovery of the defect; (b) give the model number and serial number (if applicable); and (c) describe the nature of any defect in the Product or part. At the time of the request for warranty service, you must present evidence of your proof of purchase and proof of the original purchase date. If we determine that the warranty exclusions listed above apply or if you fail to provide the necessary documentation to obtain service, you will be responsible for all shipping and other costs related to the services. This warranty is not extended or restarted upon warranty repair or replacements.

Warranty Exclusions: This warranty covers only repair or replacement, at our option, of defective Products or parts and does not cover any other costs related to the Products including but not limited to: (a) normal maintenance and service required for the Products and consumable parts such as gaskets, filters, light bulbs, fuses; (b) any Products or parts which have been subject to freight damage, misuse, negligence, accident, faulty installation or installation contrary to recommended installation instructions, improper maintenance or repair (other than by us); (c) commercial or government use of the Products or use otherwise inconsistent with its intended purpose; (d) natural wear of the finish of the Products or wear caused by improper maintenance, use of corrosive and abrasive cleaning products, pads, and oven cleaner products; (e) chips, dents or cracks caused by abuse or misuse of the Products; (f) service trips to your home to teach you how to use the Products; (g) damage to the Products caused by accident, fire, floods, acts of God; or (h) Custom installations or

alterations that impact serviceability of the Products. (l) Damage to personal property or food spoilage from use of this product. If you are outside our service area, additional charges may apply for shipping costs for warranty repair at our designated service locations and for the travel cost to have a service technician come to your home to repair, remove or reinstall the Products. All Products must be installed by a qualified professional installer to be eligible for warranty repairs or service.

Limitations of Warranty: OUR OBLIGATION TO REPAIR OR REPLACE, AT OUR OPTION, SHALL BE YOUR SOLE AND EXCLUSIVE REMEDY UNDER THIS WARRANTY. WE SHALL NOT BE LIABLE FOR INCIDENTAL, CONSEQUENTIAL OR SPECIAL DAMAGES ARISING OUT OF OR IN CONNECTION WITH THE USE OR PERFORMANCE OF THE PRODUCTS. THE EXPRESS WARRANTIES IN THE PRECEDING SECTION ARE EXCLUSIVE AND IN LIEU OF ALL OTHER EXPRESS WARRANTIES. WE HEREBY DISCLAIM AND EXCLUDE ALL OTHER EXPRESS WARRANTIES FOR THE PRODUCTS, AND DISCLAIM AND EXCLUDE ALL WARRANTIES IMPLIED BY LAW, INCLUDING THOSE OF MERCHANTABILITY AND FITNESS FOR A PARTICULAR PURPOSE.

Some states or provinces do not allow limitations on the duration of an implied warranty or the exclusion or limitation of incidental or consequential damages, so the above limitations or exclusions may not apply to you. To the extent that applicable law prohibits the exclusion of implied warranties, the duration of any applicable implied warranty is limited to the same two-year and one-year periods described above if permitted by applicable law. Any oral or written description of the Products is for the sole purpose of identifying the Products and shall not be construed as an express warranty. Prior to using, implementing or permitting use of the Products, you shall determine the suitability of the Products for the intended use, and you shall assume all risk and liability whatsoever in connection with such determination. We reserve the right to use functionally equivalent refurbished or reconditioned parts or Products as warranty replacements or as part of warranty service. This warranty is not transferable from the original purchaser and only applies to the consumer residence where the Product was originally installed located in the United States and Canada. This warranty is not extended to resellers.

Please check our website for any additional Product information, www.zephyronline.com.

Zephyr Ventilation Service Department, 2277 Harbor Bay Parkway, Alameda, CA 94502 1-888-880-8368