

ZLINE

ATTAINABLE LUXURY[®]

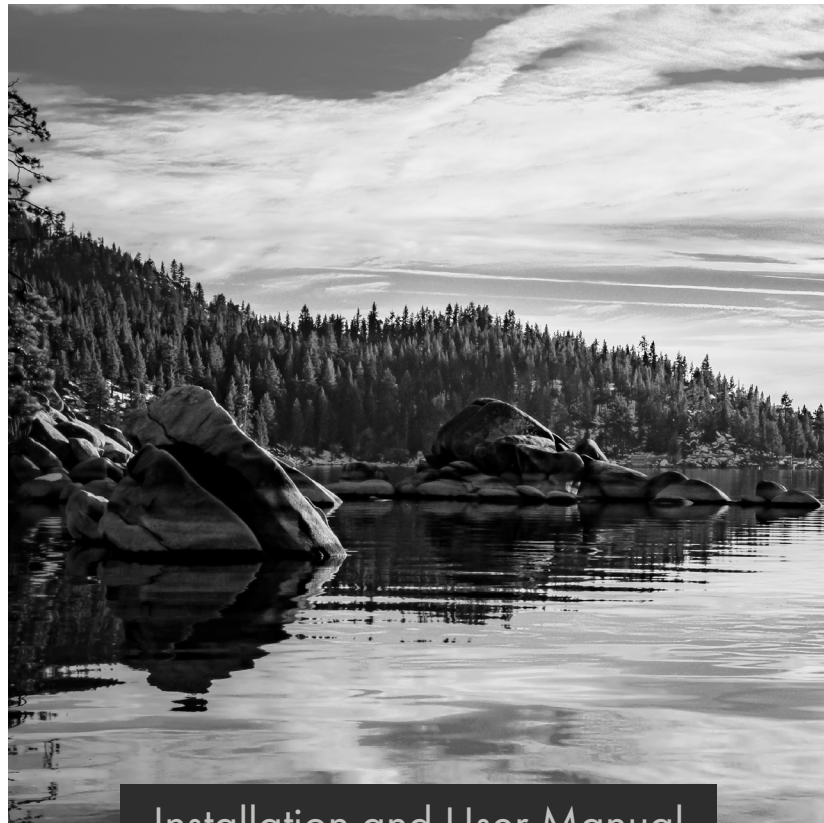

Installation and User Manual

ICE MAKERS

IGMD-ST-15, IGMDP-15, ICCD-ST-15, & ICCDP-15 MODELS

zlinekitchen.com



ZLINE Kitchen and Bath provides Attainable Luxury, where the kitchen and bath of your dreams is never out of reach. Through our unique designs and unparalleled quality, we're dedicated to providing you an elevated experience in the heart of your home. With an endless selection of features and finishes, our inspiration is your reality.

ZLINE
ATTAINABLE LUXURY®



ZLINE is fueled by a passion for innovation; A relentless pursuit of bringing the highest end luxury designs and professional features into everyone's homes.

Because we continually strive to improve our products, we may change specifications and designs without prior notice.

Scan the QR code to view the most up-to-date version of the Installation Manual and User Manual.

⚠ WARNING: This product can expose you to chemicals including nickel, which is known to the State of California to cause cancer. For more information, go to www.P65Warnings.ca.gov.

TABLE OF CONTENTS

- IMPORTANT SAFETY INSTRUCTIONS 1
 - Power Cord Precautions 3
 - Installation Precautions 4
 - Moving Precautions. 5
 - Cleaning and Maintenance Precautions. 5

- BEFORE INSTALLATION.....7
 - Product Specifications 7
 - Included Parts 8
 - Tools Needed 8

- INSTALLATION9
 - Leveling the Unit 11
 - Installing the Anti-Tip System. 12
 - Connecting the Water Supply 13
 - Filter Installation/Replacement 14
 - Electrical Connection 15
 - Reversing the Door 17
 - Custom Panel Installation - Models IGM DP-15 and ICCDP-15 20

- OPERATION 22
 - Controls - All Models. 22
 - Panel Display Notification 26
 - Ice Production. 27

- CARE AND MAINTENANCE..... 28

- TROUBLESHOOTING..... 32

- WARRANTY..... 36

IMPORTANT SAFETY INSTRUCTIONS

- **IMPORTANT:** Read all instructions before using this appliance. Use this appliance only for its intended purpose as described in this manual. Always exercise basic safety precautions, as described below. After reading this manual, store it in an accessible place where users and services can easily reference it.
- The words **DANGER**, **WARNING**, **CAUTION** and **NOTICE** are used throughout this manual to highlight important information. Be certain that the meanings of these alerts are known to all who operate and install the appliance.
- The purpose of these safety precautions is to ensure safe and correct use of the product to minimize risks that could cause serious damage and injury to you or others. Precautions are split into **WARNINGS** and **CAUTIONS**. Incidences where improper handling of the unit could lead to death or serious injury are listed under the **WARNING** heading. Incidences listed under **CAUTION** could lead to serious injury. **NOTICE** indicates a situation that can cause damage to the appliance and/or the environment or cause the appliance to operate improperly.



DANGER

Risk of fire or explosion. **FLAMMABLE REFRIGERANT** used.

- Do not use mechanical devices to defrost refrigerator.
- Do not puncture refrigerant tubing.
- This appliance is to be repaired only by trained service personnel.
- Consult the appliance's user and installation manuals before attempting service.
- All safety precautions must be followed.



CAUTION

CAUTION - Risk of fire or explosion. Dispose of refrigerator properly in accordance with the applicable federal or local regulations. Flammable refrigerant used.



CAUTION

Risk of fire or explosion if refrigerant tubing is punctured. **FLAMMABLE REFRIGERANT** used. Follow handling instructions carefully.



DANGER

DANGER - Risk of fire or explosion. Flammable refrigerant used. Do not use mechanical devices to defrost refrigerator. Do not puncture refrigerant tubing.

IMPORTANT SAFETY INSTRUCTIONS



WARNING

Do not use mechanical devices or other means to accelerate the defrosting process, other than those recommended by the manufacturer.



WARNING

Keep ventilation openings, in the appliance enclosure or in the built-in structure, clear of obstruction.



WARNING

Do not damage the refrigerant circuit.



WARNING

Do not use electrical appliances inside the food storage compartments of the appliance unless they are explicitly recommended by the manufacturer.



DANGER

DANGER - Risk of fire or explosion. Flammable refrigerant used. To be repaired only by trained service personnel. Use only manufacturer-authorized service parts. Any repair equipment used must be designed for flammable refrigerants. Follow all manufacturer repair instructions. Do not puncture refrigerant tubing.



CAUTION

CAUTION - Risk of fire or explosion due to puncture of refrigerant tubing; follow handling instructions carefully. Flammable refrigerant used.



WARNING

WARNING: Do not locate multiple portable socket-outlets or portable power supplies at the rear of the appliance.



WARNING

- Installation and service should be performed by a qualified installer. The appliance should not be adjusted or repaired by anyone except qualified service personnel. Attempting to perform these yourself could result in fire, malfunction, or injury.
- Never splash water directly onto the appliance or wash it with water without unplugging it from power, as a short circuit could result. If the appliance is installed outdoors in a humid or rainy environment, a water-proof covering is imperative.
- Never store flammable, explosive, or volatile substances inside or on top of the unit, as an explosion and fire could result.

IMPORTANT SAFETY INSTRUCTIONS

POWER CORD PRECAUTIONS

- Do not use the appliance if the power cord is damaged. If the power cord is damaged, have a qualified electrician replace the power cord.
- Never lift, carry, or drag the appliance by the power cord.
- Do not damage, modify, excessively bend, strain, twist or bundle the power cord. Avoid hot, sharp, or aggressive surfaces. Placing heavy objects on the cord or binding it could damage the cord, possibly resulting in electrical shock and/or fire.
- Use a dedicated wall outlet. Do not use an extension cord or multiple-outlet adapter, as this could result in electrical shock, overheating, and fire.
- Never use flammable spray cans or leave flammable substances near the unit. Sparks from electrical switches could result in an explosion and/or fire.
- If a combustible gas is present near the appliance, turn off the source of the gas, then open the windows and doors to allow the gas to dissipate. To avoid an explosion, do not pull the plug or switch off the unit.
- The electrical socket must be properly grounded and the plug should always be accessible. The ground wire cannot be connected with a gas pipe, heating pipe, water pipe, telephone line, or lightning rod. It cannot be replaced with the neutral wire of single-phase power.
- For standard indoor installation, it's recommended that a dedicated electrical circuit suitable for a NEMA 5-15 outlet serving only your appliance be used; please ensure the outlet is easily accessible.
- In addition to the ground wire, an electrical leakage circuit breaker is required if the unit is installed outdoors.
- An electrician-installed ground fault circuit interrupter (GFCI) electrical outlet is also required for outdoor installation. If no GFCI is installed, electrical shock could result.
- Never climb onto or inside the unit. The unit could tip over or fall and cause material damage or personal injury.
- Disconnect the power cord plug from the wall outlet before moving the unit and make sure that the power cord is not damaged during transport. A damaged power cord could result in electrical shock and/or fire.
- Never unplug the unit by pulling on the power cord. Always grip the plug firmly and pull straight out from the outlet. Pulling the cord could cause wire breakage, possibly resulting in overheating and fire. Never pull out plug when hands are wet.
- Have a qualified technician repair or replace any cord that is frayed or damaged. Do not use a cord that shows cracks or abrasions along its length.
- Keep the appliance's ventilation openings, whether in the appliance enclosure or in the built-in structure, clear of any obstruction.

IMPORTANT SAFETY INSTRUCTIONS

INSTALLATION PRECAUTIONS



CAUTION

- This unit must be properly installed in accordance with the installation instructions including in this manual, along with adhering to all local government codes, before it is used. See electrical instructions on page 15.
- Connect to potable water supply only.
- Built-in units vent air out of the grill located at the bottom front of the ice maker. To ensure proper service access and ventilation, all units should not have the grill openings covered. There are no additional requirements for venting at the top, side, or rear of the unit.
- Install the unit in a location where the floor is sturdy enough to support the load of the unit. If the floor is not sturdy enough or installation is incorrectly performed, the unit could tip over and cause personal injury.
- Never place heavy objects or items containing water on top of the unit. Objects could fall and cause injury, and spilled water or other liquids could cause the deterioration of the insulation of electrical components and result in electrical shock.
- Disconnect the unit if it is behaving abnormally, and do not reconnect until the situation is corrected. If normal troubleshooting measures do not work, contact ZLINE at 1-614-777-5004 for assistance.
- Unplug the appliance before performing any maintenance to avoid electric shock.
- This unit is not intended for the storage of medicines, vaccines, or chemical reagents.
- Keep all packing materials away from children.



WARNING

Risk of child entrapment. To avoid safety and suffocation risks for children or pets, before you dispose of the appliance, take off the doors and drawers and leave the shelves in place so children or pets may not climb inside.

- Condenser water from the appliance evaporator drains into a hole in the floor of the storage compartment and is channeled into a drain pan located at the back of the appliance on the compressor. Heat transferred from the compressor evaporates any water that has collected in the pan. Be sure the drain hole in the floor of the unit is clear and unobstructed.
- This appliance is CFC- and HFC-free and contains small quantities of propane (R290), an environmentally friendly refrigerant.

IMPORTANT SAFETY INSTRUCTIONS

- During long absences, remove the unit's contents, unplug the unit, clean it, and leave the door open slightly to avoid possible formation of condensation, mold, or odors. Use a cover to protect the unit and prolong its lifespan.
- Leave disassembly and disposal of the unit to qualified experts. The manufacturer will not be responsible for any damage to property or to persons caused by incorrect installation, improper use of the appliance, or failure to heed the warnings listed, and the warranty will be voided.
- The manufacturer reserves the right to make changes to its products when considered necessary and useful, without affecting the essential safety and operating characteristics.
- This appliance has been designed for non-commercial, domestic use only.
- Please observe all local, state, and national codes and ordinances. Please ensure the appliance is properly grounded. The plug should always be accessible.
- Never use an appliance with a damaged cooling system. If system is damaged upon arrival, contact ZLINE at 1-614-777-5004.

DISPOSAL

The appliance cannot be treated as normal domestic trash and must be disposed of at a collection point for recycling electric and electronic appliances. Your contribution to the correct disposal of this product protects the environment. Further information about the recycling of this product can be obtained from your local municipal authority.

MOVING PRECAUTIONS

- When moving the appliance, do not turn it upside-down and do not tilt it more than 45°.
- Do not move the appliance without emptying it and securing the door in the closed position.

CLEANING AND MAINTENANCE PRECAUTIONS

- Never clean the appliance parts with flammable fluids. Do not store or use gasoline or other flammable vapors and liquids in the vicinity of this appliance or any other appliances. The fumes can create a fire hazard or explosion.
- Do not use solvent-based cleaning agents or abrasives on the interior. These cleaners may transmit taste to the ice cubes, or damage or discolor the interior.
- If the appliance will not be used for a long time, thoroughly clean it before the next use. Carefully follow any instructions provided for cleaning or the use of sanitizing solution. Do not leave any solution inside the appliance after cleaning.

IMPORTANT SAFETY INSTRUCTIONS

OTHER PRECAUTIONS

- To ensure proper ventilation for the appliance, keep obstructions away from the front of the unit.
- Keep fingers out of the “pinch point” areas. Clearances between the door and cabinet are necessarily small. Be careful closing the door when children are in the area.
- Do not touch the evaporator with your hand when the appliance is operating.
- Do not attempt to repair or replace any part of your appliance unless this manual specifically recommends it. Have a qualified technician perform all other service on the unit.
- Never allow children to operate, play with, or crawl inside the appliance.
- Never allow children to clean and maintain the machine without supervision.
- Do not use the appliance other than for its intended purpose.
- Do not touch the condenser surfaces. They are sharp and can be easily damaged.
- Never turn off the water supply while the unit is running. During installation, turn the water supply on prior to turning on the unit. Always turn the unit off prior to turning off the water supply.
- Except to take ice from the unit, keep the door closed to reduce melting and ensure proper ice formation.

BEFORE INSTALLATION

PRODUCT SPECIFICATIONS



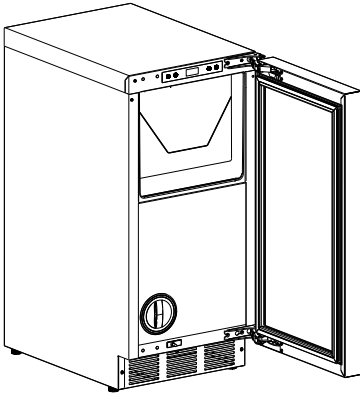
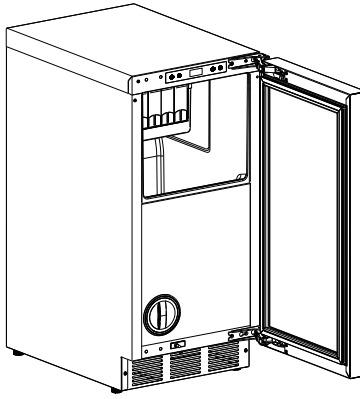





NOTE: Technical data and performance information are provided for reference only and subject to change.

Model	ICCD-ST-15 & ICCDP-15	IGMD-ST-15 & IGMDP-15
Image		
Electrical requirements	115 VAC/60 Hz	
Maximum amp fuse	15 amps	
Indoor/Outdoor	Indoor/outdoor* *The unit cannot be directly exposed to water or elements such as snow or ice. For areas subject to freezing, follow the instructions for "Extended periods of non-use" on page 30 .	
IP rating	IPX4	
Ambient operating range	50 °F–110 °F (10 °C–43 °C)	
Water operating range	40 °F–90 °F (4 °C–32 °C)	
Water pressure operating range	20~80 psi (0.138~0.55MPa)	
Water inlet adapter	1/4" OD compression fitting	
Ice shape	Cube	Octagon/Gourmet
Ice production capacity (70 °f/50 °f)	75 lb (34 kg)** **The actual quantity of ice produced per day will vary with ambient room and water conditions.	66 lb (30 kg)** **The actual quantity of ice produced per day will vary with ambient room and water conditions.
Ice storage capacity	26 lb (12 kg)	
Ice size (W × D × H)	7/8" W × 7/8" D × 7/8" H	1 1/4" W × 1 1/4" D × 1" H
Ice weight	About 0.4oz (11g) per cube	About 0.81oz (23g) per cube
Ice cube quantity per cycle	40	24
Unit dimensions (W × D × H) [Not including handle]	ICCD-ST-15 & IGMD-ST-15 14 7/8" W × 23 1/4" D × 34" H 378 mm W x 591 mm D x 864 mm H	
	ICCDP-15 & IGMDP-15 14 7/8" W × 22 1/2" D × 34" H 378 mm W x 572 mm D x 864 mm H	
Net weight	ICCD-ST-15 95 lb (43 kg)	IGMD-ST-15 97 lb (44 kg)
	ICCDP-15 86 lb (39 kg)	IGMDP-15 88 lb (40 kg)

BEFORE INSTALLATION

BEFORE USING YOUR ICE MAKER

INCLUDED PARTS

DESCRIPTION	IMAGE	QUANTITY
Ice scoop		1
Installation and user manual		1
Anti-tip brackets		2
Screws for anti-tip brackets		6
Foot adjustment wrench		1
* Door limiting pins		2
** Screws for custom panel installation (models IGMDP-15 and ICCDP-15 only)		6
Decorative plugs		4
Allen key		1

** Not needed for stainless steel door models; see page 20 for panel-ready information.

TOOLS NEEDED

- 1 Phillips screwdriver

INSTALLATION

PLUMBING AND ELECTRICAL TIPS

- A licensed plumber must install this appliance.
- This appliance must be installed with all electrical and water connections in accordance with state and local codes.
- This unit requires a standard electrical supply properly grounded in accordance with National Electrical Code and local codes and ordinances.
- The fuse (or circuit breaker) size should be 15 amperes for 115 V.
- We recommend that you provide a dedicated circuit that services only your appliance. Use receptacles that cannot be turned off by a switch or pull chain.
- Plug the appliance into a grounded three-prong outlet. Do not remove the grounding prong, do not use an adapter, and do not use an extension cord.
- Do not kink, pinch, or damage the power supply cord between the ice maker and wall or cabinet.
- Before connecting the ice maker to the power source, let it stand upright for approximately 4 hours. Following this step will reduce the possibility of a malfunction in the cooling system brought on by handling during transportation.
- Make sure to install on level surface and ensure drain line and waterline are not kinked.

TIPS ON MOVING AND SETTING UP THE UNIT

- Use two or more people to move and install the appliance. Failure to do so can result in back or other injury.
- Remove the packing materials and clean the appliance before using it.
- Do not tip the unit beyond 45°.

INSTALLATION

BUILT-IN INSTALLATION

A built-in installation will allow you to install the ice maker under a counter or in a kitchen cabinet if you follow the required clearance space around the clear ice maker. The appliance must be located in a manner that allows clearance for water, drain, and electrical connections in the rear of the unit.

BUILT-IN CABINET DIMENSIONS

A built-in installation requires for a water line and plug clearance for proper operation. A built-in unit is designed for zero clearance at the top and each side of the unit. The unit uses fan-forced condenser cooling, which requires air circulation through the lower section of the unit. To ensure proper service access and ventilation, the unit should not have the grill openings covered. There are no additional requirements for venting at the top, side, or rear of the unit.

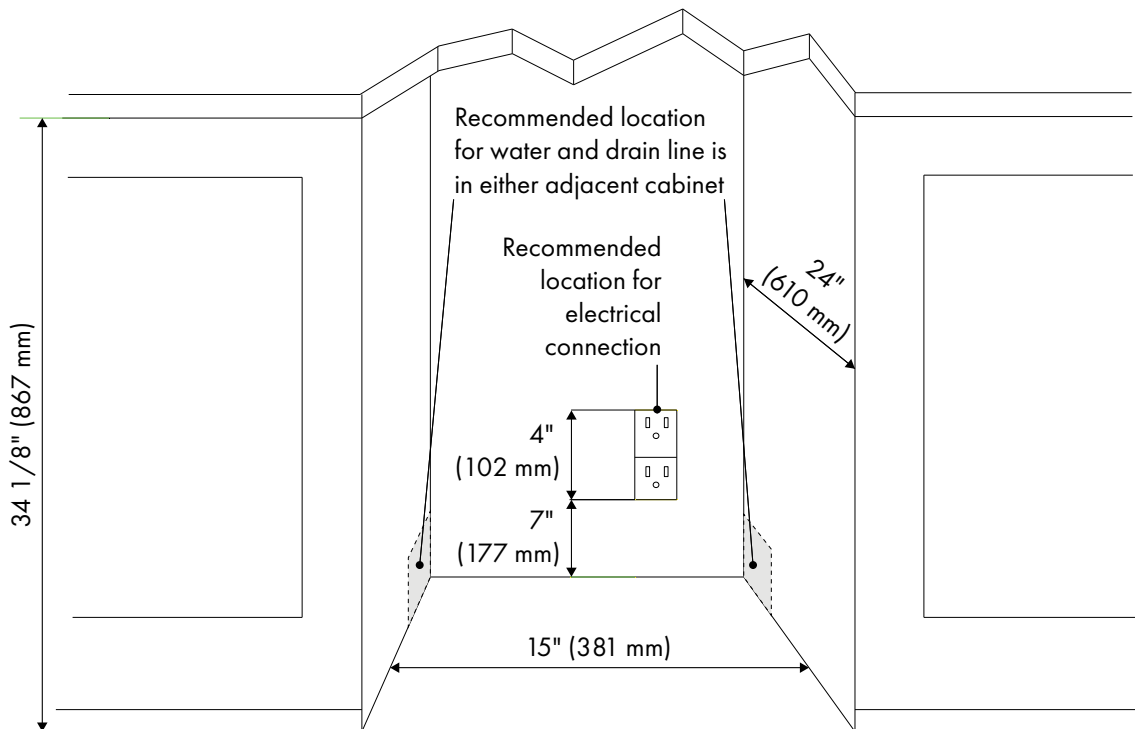

NOTICE

- Ensure that the air path for the grill remains unrestricted. Any restriction of air flow through the grill will disrupt normal operation of the unit, resulting in damage to components, which voids the warranty.
- Connect the unit to a potable water supply only.

INSTALLATION

LEVELING THE UNIT



CAUTION

The unit will be significantly heavier once it is operational and fully loaded.

Place your ice maker on a level surface that is strong enough to support the ice maker when it is fully loaded. Level your ice maker by adjusting the legs at the front of the ice maker with the foot adjustment wrench. If necessary, raise or lower the unit by turning the four leveling feet on the bottom.

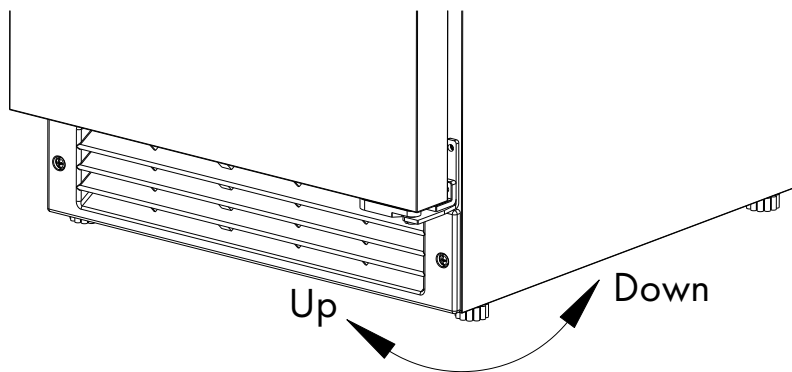

INSTALLATION

INSTALLING THE ANTI-TIP SYSTEM

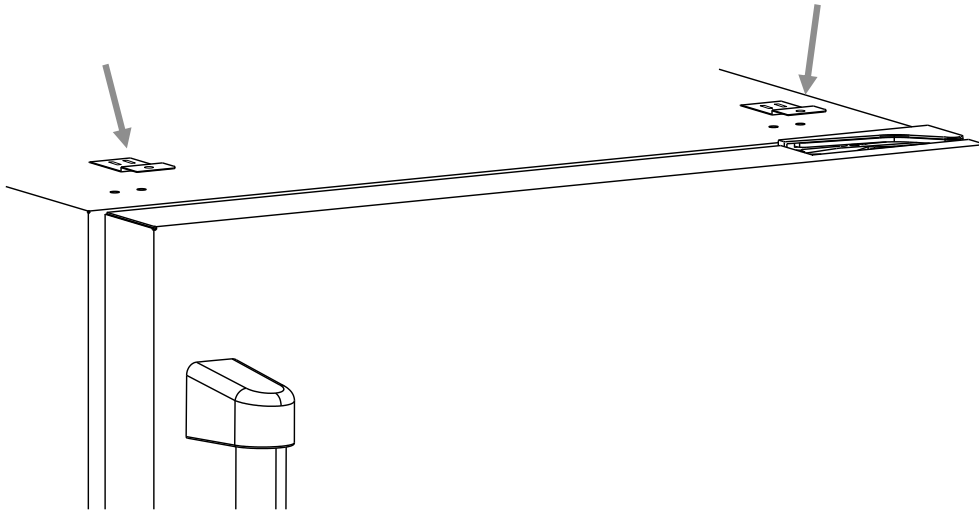

1. With built-in installations, once you've determined the appropriate height and have ensured the appliance is level, position the unit at the front of the cutout to install the anti-tip system, which is necessary to reduce risk of tipping.
2. Using a Phillips-head screwdriver or drill, secure the 2 anti-tip brackets to the top of the unit using 4 of the provided screws, 2 for each bracket, making sure the lips of the brackets are facing up and out, as outlined in the image above. **NOTE:** The unit comes with small plastic plugs that fit in the screw holes. The plugs will need to be removed from the screw holes before proceeding.
3. Plug the power cord into the wall and push the unit into the cutout, using care to not tangle or damage the power cord.
4. Once the appliance is in the cutout, secure the anti-tip brackets into the countertop above using the last 2 screws.



WARNING The anti-tip system must be properly engaged with built-in installations to avoid the unit tipping over and increasing risk of serious injury or death.

INSTALLATION



ELECTRICAL SHOCK HAZARD

WARNING

Always disconnect power at the source before working on the unit. Failure to unplug the ice maker could result in electrical shock or personal injury.

- Do not touch the power plug when your hands are wet.
- Never unplug the unit by pulling on the cord. Grasp the plug and pull out firmly.

WATER SUPPLY TIPS

- Check for leaks after connecting the water line.
- The ice maker requires a continuous water supply with a minimum pressure of 20 psi (0.138 MPa) and a static pressure not to exceed 80 psi (0.55 MPa).
- Using a reverse osmosis filter may cause the water pressure to be lower than the minimum the ice maker requires.
- Ensure that the water supply hose is not pinched, kinked, or damaged during installation.

CONNECTING THE WATER SUPPLY

1. Turn off the main water supply. Turn on the nearest faucet long enough to clear a line of water.
2. Find a 1/2" to 3/4" vertical cold-water pipe near the installation location. The distance should be less than 9' (2743 mm).
3. Install a shut-off valve to the main water supply. If the water pipe has a plain piece of copper tubing, attach a 1/4" O.D. compression union to the tubing and remove the nut.
4. Thread the nuts of the supplied water supply hose to the tap and water inlet valve. Access to the water inlet valve is through the opening in the rear panel. Tighten firmly by hand, then one-half turn with a wrench.
5. Turn on the main water supply and tap. Check for leaks in the water supply connection. Tighten all connections.

INSTALLATION

FILTER INSTALLATION/REPLACEMENT

The water filter must be installed in accordance with manufacturer's recommended procedures and guidelines to reduce the risk associated with property damage due to water leakage. You must read and follow installation and use instructions before installation and use this product.



Visit www.zlineparts.com and search "IMP-013" to order a replacement.

1. Rotate the water filter cover 90° counterclockwise. Remove the cover.
2. Grasp the base of the water filter. Rotate the filter counterclockwise until it feels loose.
3. Pull the water filter out of the machine.

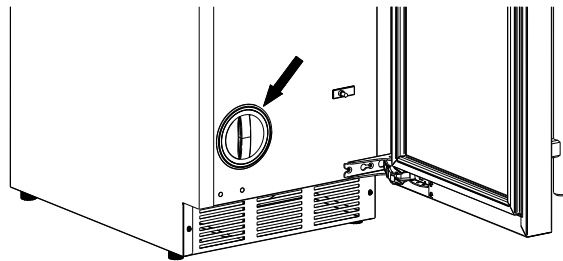

4. Using a new water filter, first remove its cap, then insert the filter into the machine aligning tabs on the filter with slots in the water filter head.
5. Push in the filter and rotate it clockwise to let the tabs lock in to the slots.
6. Install the water filter cover by rotating the cover 90° clockwise.

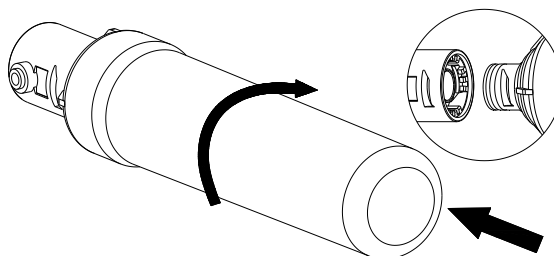

WARNING

The water filters come with a cap. Do not install with the cap on, as it will be difficult to remove.



CAUTION

The ice maker will NOT work if the filter is not properly installed.

INSTALLATION

ELECTRICAL CONNECTION

Do not, under any circumstances, cut or remove the third (ground) prong from the power cord. For personal safety, you must properly ground this appliance. The power cord of this appliance features a three-prong grounding plug that mates with a standard three-prong grounding wall outlet to minimize the possibility of electric shock hazard from the appliance.

Have a qualified electrician check the wall outlet and circuit to make sure the outlet is properly grounded. It is your responsibility and obligation to have a standard two-prong wall outlet replaced with a properly grounded three-prong wall outlet.

Always plug the appliance into its own individual electrical outlet. The voltage rating of the outlet must match the rating label on the appliance. This provides the best performance and prevents overloading the electrical circuits, which could cause a fire hazard from overheated wires. Never unplug your appliance by pulling on the power cord. Always grip the plug firmly and pull straight out from the outlet.

Repair or replace immediately all power cords that have become frayed or damaged. Do not use a cord that shows cracks or abrasion damage along its length or at either end. When moving the appliance, take care not to damage the power cord. If the supply cord suffers damage, have the manufacturer, its service agent, or similarly qualified, persons replace the supply cord to avoid a hazard.

AVOIDING USE OF EXTENSION CORDS

Because of potential safety hazards under certain conditions, the manufacturer strongly recommends that you do not use an extension cord with this appliance.

INSTALLATION

DRAIN PUMP TIPS



ELECTRICAL SHOCK HAZARD

Be sure the floor surfaces surrounding the appliance are dry before plugging in and removing the power cord to the outlet to prevent electrical shock.

Follow these steps to test the operation of the drain pump before final installation:

1. Check the power cord and make sure it is not plugged into the outlet.
2. Place the drain hose into a suitable container that can hold at least one gallon.
3. Pour one gallon of water into the ice storage bin.
4. Plug the power cord into a properly grounded, polarized electrical outlet.
5. The drain pump should start and pump the water into the container.
6. Unplug the power cord.



Drain pump operation should be tested every time the appliance is cleaned and sanitized. If the drain pump is not operating properly, water could back up and overflow, leading to costly water damage.

INSTALLATION

REVERSING THE DOOR

This appliance has the capability of the door opening from either the left or right side. The appliance is delivered to you with the door opening from the left side. Follow these instructions should you desire to reverse the opening direction.



CAUTION

Before operating, check the power cord and make sure it is not plugged into the outlet.

NOTE: THE HANDLE DOES NOT NEED TO BE REMOVED TO REVERSE THE DOOR.

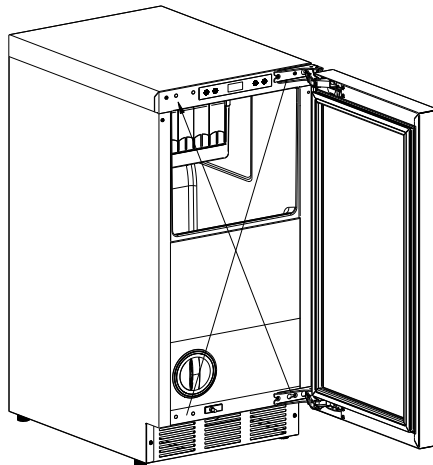

1. With the door open, carefully remove the 4 plugs at the top and bottom of the left side of the appliance cabinet face. Save the plugs to reinstall once the door reversal is complete.
2. Loosen but do not remove the outer top and bottom screws on the right-side hinges.
3. Completely remove the inner top and bottom screw on the right-side and install the 2 removed screws about three turns into the left-side outer top and bottom screw locations where the plastic plugs were removed.
4. Carefully slide and lift the door off of the 2 remaining screws on the right-side. Then turn/rotate the door 180° and reposition the hinges on the 2 partially installed left-side screws.
5. Remove the outer top and bottom screws from the right-side hinges and install them in the open inner holes in the left-side hinge location. Tighten all screws.
6. Close the door and check for good alignment with the cabinet. If needed, loosen the 4 screws enough to slide the door a bit to fine tune the alignment, then re-tighten all 4 screws and install the plugs into the four open holes on the right side.

INSTALLATION

DOOR SWING

All units come with doors installed at the pre-set maximum door swing of 135°. If you desire to limit the door swing to 90°, insert the 2 provided door limiting pins into the pin hole on the top and bottom door hinges, as show in the image below.



Door Limiting Pin Location

DOOR HINGE TIGHTENING

The appliance's door hinges may loosen over time, which is normal with regular use. Use the provided Allen key to loosen or tighten screws securing the hinges to the door as necessary, as outlined in the image below for ICCDP-15 and IGMDP-15 models. For ICCD-ST-15 and IGMD-ST-15 models, hinge screws are located behind the rubber door seal. You can easily remove the upper corners of the seal by hand to access the screws.

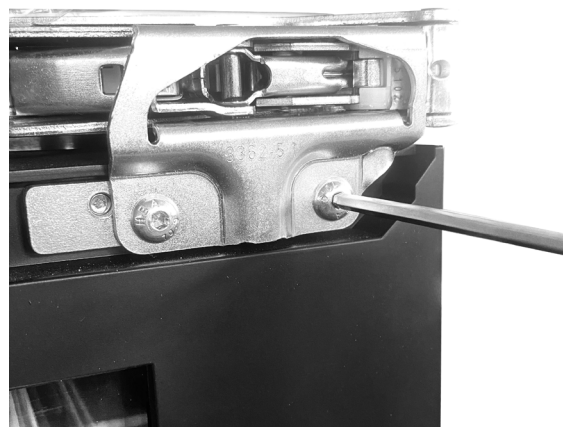

INSTALLATION

HANDLE INSTALLATION

Prior to installing a custom panel, handle(s) need to be affixed to the panel first. If you wish to install a ZLINE Autograph Edition handle onto your custom panel, reference the measurements displayed in the diagrams below regarding where to affix the mounting studs.

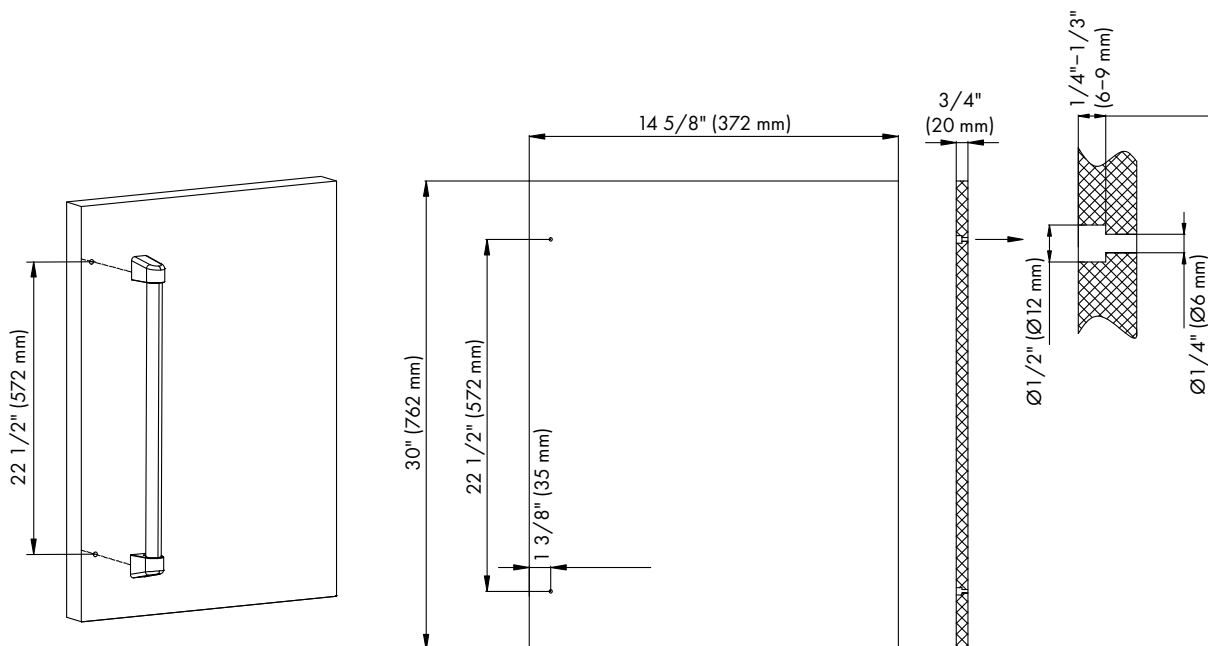

INSTALLATION

CUSTOM PANEL INSTALLATION - MODELS IGMDP-15 AND ICCDP-15

A custom door panel/frame can be fabricated for the appliance. Handle hardware must also be provided, if needed.

Finish all sides of the custom panel. They may be visible when the door is open.

NOTE: Hole pattern dimensions for blind pilot holes only.

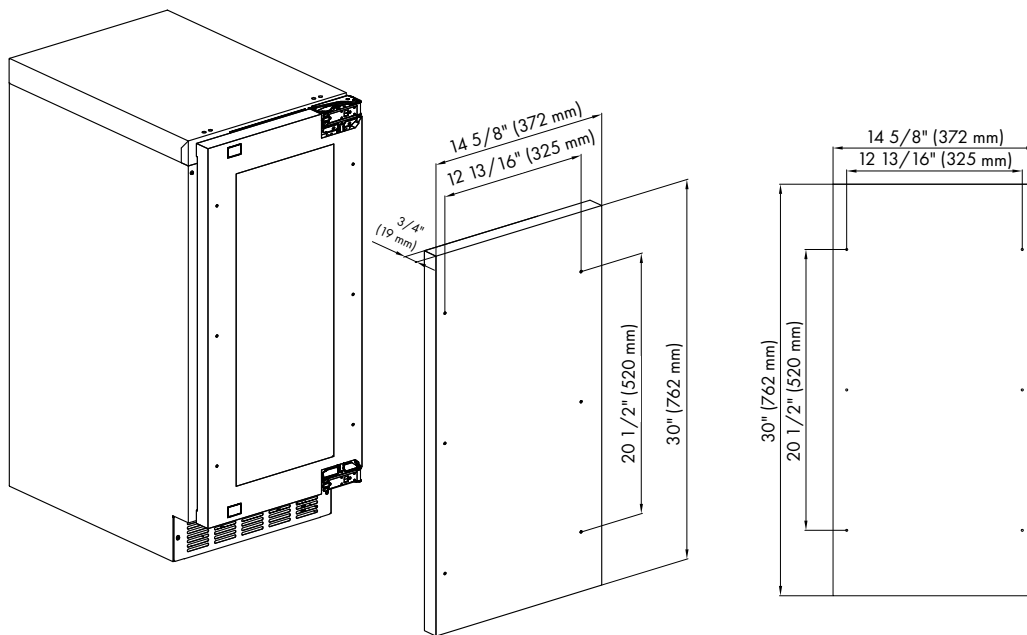

Maximum panel weight: 25 lb (11 kg)

Minimum panel thickness: 3/4" (19 mm)*

INSTALLING THE CUSTOM PANEL

1. Remove the door from the unit.
2. Remove the door seal to gain access to the custom door panel mounting holes.
3. Align the top of the custom door panel flush with the top of the door.
4. Adjust the overlap of the custom door panel so it is equal on both sides of the door.
5. Secure the custom door panel to the door using 6 wood screws (provided).
6. Reinstall the door seal. Be sure the seal is properly seated.
7. Reinstall the door to the unit.

* Take into account the thickness of the custom panel, as the provide screws may penetrate through the face of the custom panel.

INSTALLATION

INTEGRATED GRILL/PLINTH

An integrated grill/plinth can be fabricated, if desired. The thickness of the panel should be between 1/4" to 3/8" (6 mm to 9 mm) and the height will vary between 3 5/16" to 4 5/16" (84 mm to 110 mm) depending on your grill/plinth height. Be sure to fabricate slots in the custom plinth to prevent venting issues.

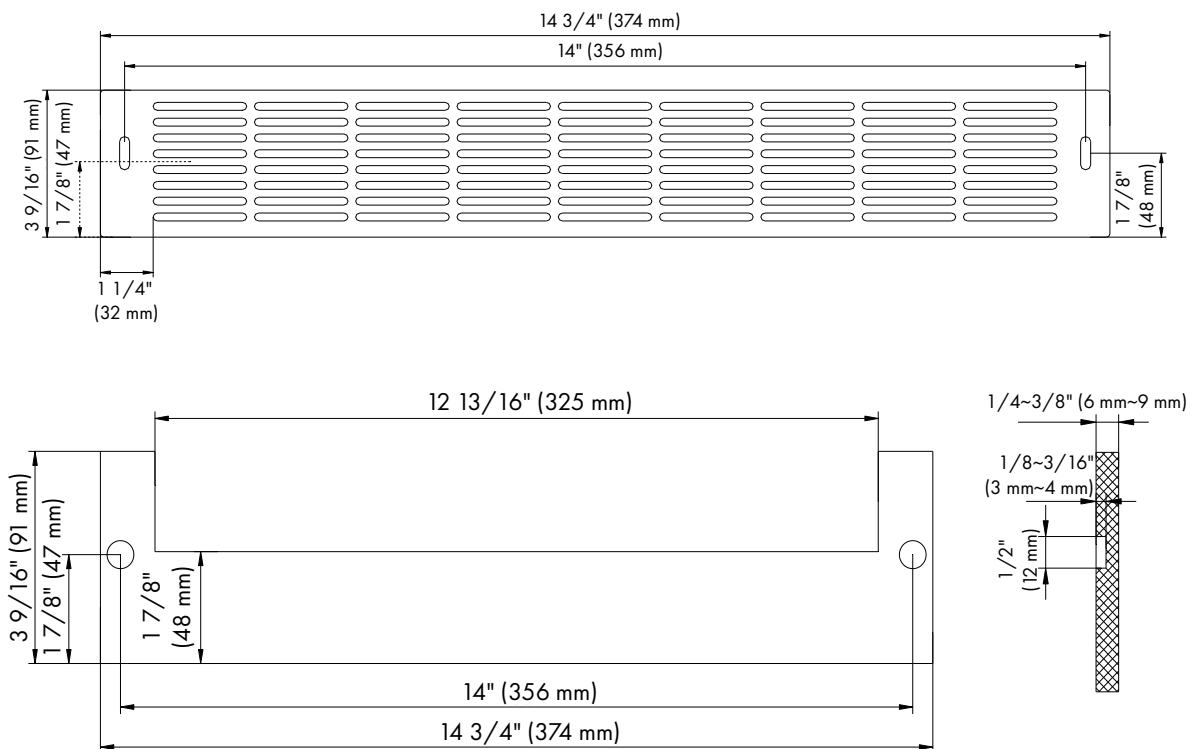

NOTE: When finishing the grill/plinth, be sure to stain front, back, and all edges to prevent warping.

OPERATION

CONTROLS - ALL MODELS

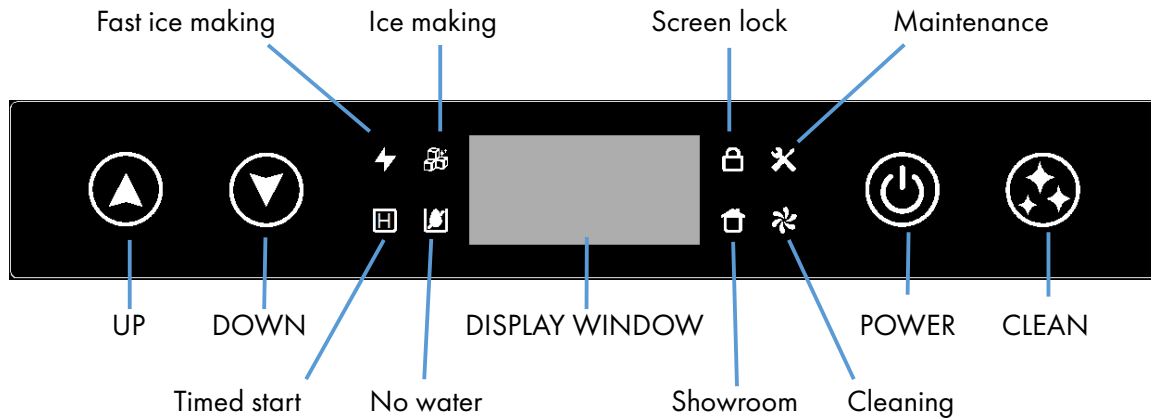

The control panel is located at the top of the cabinet. It includes a display window, 4 buttons, and 8 indicators.

Turn ON (☰): Press **POWER** to turn **ON** the unit.

- The unit will automatically start making ice and display:
 - ☰ during ice making
 - ☰ during ice harvesting
 - FULL when the bin is full of ice
- The ice making symbol will illuminate when making ice.
- **NOTE:** When the unit is initially powered on, it will display 888, then FULL. 888 is a Self-Diagnosis pass that only occurs when the unit is initially powered on. FULL states that the unit is filling with water in preparation for making ice.

Turn OFF/Standby (⏻): Press and hold **POWER** for 3 seconds to immediately turn **OFF** the unit.

- The unit will be in standby and will display OFF.

Adjust the ice cube size (⏻): Press and hold **DOWN** for over 3 seconds to enter **Ice Size Adjustment**. Then press **UP** or **DOWN** to adjust.

- The display will show 1 to 5 (min to max). 3 is the default ice size.
- The setting will be saved after 7 seconds.

OPERATION

ICE CUBE SIZE SETTINGS

ICCD-ST-15 & ICCDP-15 MODELS

For ICCD-ST-15 & ICCDP-15 models, the hollow shape inside each cube will increase or decrease depending on which size level is chosen. For example, Level 1 produces the smallest cube, while Level 6 produces the largest, as outlined below.

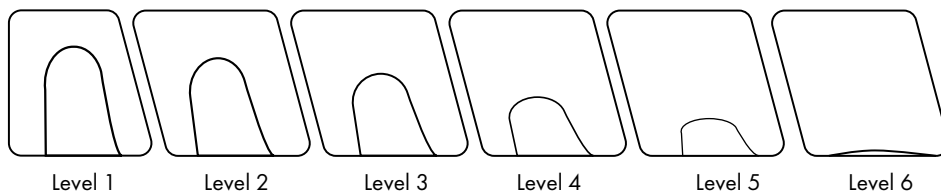

IGMD-ST-15 & IGMDP-15 MODELS

For IGMD-ST-15 & IGMDP-15 models, the hollow shape inside each cube will increase or decrease depending on which size level is chosen. For example, Level 1 produces the smallest cube, while Level 6 produces the largest, as outlined below.

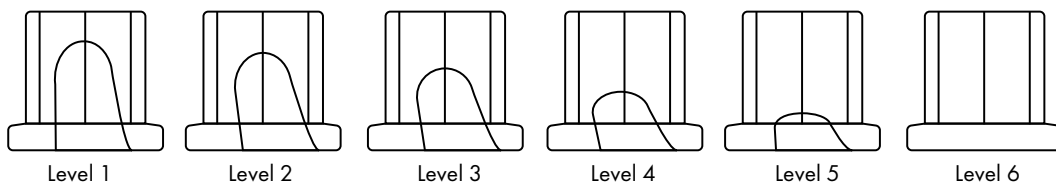

OPERATION

Fast Ice Making (⬆️⬇️): Press and hold UP and DOWN for over 3 seconds to toggle ON/OFF Fast Ice Making.

- The fast ice-making symbol will illuminate — during this mode the ice-making cycle will be shorter.

Timed Ice Making (⏻⬆️⬇️): When in Standby, press and hold POWER and CLEAN for over 3 seconds to toggle ON/OFF Timed Ice Making.

- Once toggled ON, press UP or DOWN to select between 1 to 12 hours for the timer. The setting will auto-save after 10 seconds, the window will display the countdown time in hours, and the timed ice-making symbol will illuminate.
 - For example, if you set the timer to 6 hours, the unit will wait 6 hours before starting the ice-making process.
- Pressing POWER will skip the countdown and immediately start ice making.

Cleaning (⬆️⬇️): When in Standby, press and hold CLEAN for over 3 seconds to turn ON/OFF the SELF CLEANING CYCLE.

- Once started, the window will display 30 and the clean indicator will illuminate. The clean cycle will run for 30 minutes and then the unit will return to standby.
- This function can only be started from standby.

Sabbath Mode (⬆️⬇️): Press and hold UP and CLEAN for over 6 seconds to turn ON/OFF SABBATH MODE.

- When in Sabbath Mode, the display, interior light, and any audible tone will be disabled.

Showroom Mode (⬇️⬆️): When in Standby, press and hold DOWN and CLEAN for over 6 seconds to toggle ON/OFF SHOWROOM MODE

- The Showroom indicator will illuminate.
- Showroom Mode allows you to the display the unit without operation.

Control Lock (⏻⬆️⬇️): Press and hold POWER and CLEAN for over 6 seconds to LOCK/UNLOCK the controls.

- The screen lock indicator will illuminate and the controls will be locked. Repeat this action to unlock the controls.

OPERATION

Filter Reset (▲ ⏻): After replacing the water filter, press and hold UP and POWER for over 6 seconds to reset the filter timer.

- The display flashes F 1 1 as a filter replacement reminder.
- This function can only be performed while the unit is on standby. Only reset this after replacing the water filter

Factory Reset (▼ ⏻): Press and hold DOWN and POWER for over 6 seconds to reset all the settings to default.

EXPECTING NORMAL SOUNDS

Your new ice maker may make sounds that are not familiar to you. Hard surfaces like the floor and walls can make the sounds seem louder than they actually are. The following describes the kinds of sounds that might be new to you and the source of those sounds, which are normal as part of the machine's operation:

- The high-efficiency compressor may make a pulsating or high-pitched sound.
- Water running from the evaporator to the water reservoir may make a splashing sound.
- As each cycle ends, you may hear a gurgling sound due to the refrigerant flowing through your ice maker.
- Rattling noises may come from the flow of the refrigerant or the water line or items stored on top of machine.
- You may hear the sound of the condenser fan forcing air over the condenser.
- During the harvest cycle, you may hear the sound of ice cubes falling into the ice bin.

OPERATION

PANEL DISPLAY NOTIFICATION

Self-diagnosis pass	888	Only displays on the beginning of the working progress.
Filling water	FIL	
Ice bin is full	FULL	If the ice storage bin is full, the unit will automatically stop. Remove the ice and the unit will start making ice after 3 minutes.
Door ajar alarm	dr	If the door is not closed completely for 5 minutes, the panel will flash dr with alarm sounds. The alerts will stop when the door is closed or any button is pressed.
Clean reminder	CLE	When the unit has worked for approximately 6 months without running the CLEANING program, the panel will flash CLE as the reminder. Run CLEANING to clear the alarm.
Filter replace reminder	F I I	When the unit has worked for approximately 6 months, the panel will flash F I I as the reminder. Replace the filter and reset the filter timer to clear the alarm.

OPERATION

IMPORTANT: ENSURING ICE FRESHNESS AND QUALITY

- Although the unit has been tested and cleaned at the factory, discard the first batch of ice cubes due to long-term transit and storage.
- If you do not use the ice maker regularly, empty the ice bin periodically to ensure ice freshness.
- The ice maker produces ice in layers resulting in a clear cube. The ice may appear wet when first produced. Ice in the bin may develop surface frost which appears when the cube is placed in liquid.

ICE PRODUCTION

ICCD-ST-15 & ICCDP-15 - The ice maker will continue to produce ice until the ice in the bin reaches the discharge location, not allowing the harvested ice to enter the bin. Once the ice level in the bin drops, the ice maker will continue to produce ice.

IGMD-ST-15 & IGMDP-15 - The ice maker will continue to produce ice until the ice in the bin contacts the fill indicator in the bin. Once the ice level drops below the fill indicator, the ice maker will continue to produce ice.



Out of the Ordinary Ice Production

Please note that the ice production following a cleaning cycle could produce excessive splashing and or uneven/irregular shaped ice cubes. This is normal and should correct after several harvests.

OTHER OPERATING TIPS

- Keep the air intake and exhaust free of dust and lint to allow free air flow with hard water, cleaning may have to be more frequent. **NOTE:** Ensure that custom kick plates allow for ventilation.
- Never touch the evaporator when the unit is running.
- Keep the door closed to reduce ice melting and to promote proper ice formation. Open the door only when taking ice from the appliance.
- Turn on the water supply tap before switching on the ice maker. Never turn the water supply tap off when the ice maker is working.

CARE AND MAINTENANCE

CLEANING AND MAINTAINING THE UNIT

Perform periodic cleaning and proper maintenance to ensure efficiency, top performance, and long life. Maintenance should be performed every 3 to 12 months depending on usage and environment:

- Regularly inspect plumbing connections to ensure that no leaks exist.
- Disconnect the water supply line if the ice maker will not be used for a long period of time.
- Never keep anything in the ice storage bin that is not ice. Objects such as wine and beer bottles are not sanitary and could damage the bin liner.

CONDENSER CLEANING

Periodically vacuum dust and dirt from the condenser, which is located behind the grill at the bottom front of the unit. A condenser that is dirty or clogged will prevent proper airflow and reduces ice making capacity.



WARNING

Do not use solvent-based or abrasive cleaners. Use a soft sponge and rinse the unit with clean water. Wipe the unit with a soft, clean towel to prevent water spotting.

CLEANING THE UNIT'S INTERIOR

When necessary, defrost and thoroughly clean the inside of the unit with mild soap and water. Do not use electrical heating devices or sharp or pointed tools when defrosting the unit. When defrosting or leaving the unit turned off, leave the door propped open. Leaving the door open allows air to dry the inside of the cabinet, reducing the chance for mildew and mold damage to mechanisms or components.

CLEANING THE UNIT'S EXTERIOR

Clean the door and cabinet with a mild detergent and warm-water solution, such as 1 oz. (28 g) of dish-washing liquid mixed with 2 gallons (7.5 L) of warm water. Clean stainless steel with a mild detergent, a warm-water solution, and a damp cloth. Never use an abrasive cleaning agent.

RUNNING THE CLEANING CYCLE

Minerals that are removed from water during the freezing cycle will eventually form a hard, scaly deposit in the water system; cleaning the system regularly helps remove mineral buildup. How often to clean the system depends upon how hard your water is or how effective a water filtration system may be. With hard water of 15 to 20 grains/gal, you may need to clean the system more often. Normal timing will range from 3 to 12 months depending on water, use and environment.

CARE AND MAINTENANCE



Failure to regularly clean and maintain your ice maker may result in component failures or damage, which will void your warranty.

STEPS TO CLEAN AND SANITIZE THE ICE MAKER

1. Turn off the ice maker – press power on/off button.
2. Remove ice from bin and evaporator:
 - a. Wait for ice to melt off the evaporator and leave the door open (approximately 30 to 60 minutes).
 - b. Remove remaining ice from the bin. Discard or store in a freezer until cleaning is complete.
3. Remove evaporator cover to expose evaporator and water trough.
4. Pour 1 oz. to 2 oz. (28 g to 56 g) of nickel-safe ice maker cleaner in the water trough (more cleaner depending on scale and timing in between cleanings).
5. Press light button for over 3 seconds to enter cleaning cycle -  will be displayed:
 - a. The unit will now run a cleaning cycle for 30 minutes
 - b. If excessive scale has built up, a second cleaning cycle may be required. Repeat steps 4–5.
6. After the cleaning cycle is complete, check to see if scale is visible on other parts in the interior of the ice maker. If so, move to step 7 or, if no visible scale, move to step 8.
7. Dilute 1 oz. to 2 oz. (28 g to 56 g) of nickel-safe ice maker cleaner with 2 quarts (2 L) of warm water, then use a sponge or cloth to wipe the interior of the bin, water reservoir, tubing, evaporator cover, and back of the door. **DO NOT WIPE OR TOUCH THE EVAPORATOR.** For safety and effectiveness, use the solution immediately after dilution.
 - a. After wiping down is complete, dilute 1 tablespoon (15 ml) of chlorine bleach with 1 gallon (4 L) of warm water. This solution will remove the ice maker cleaner. Repeat the wipe down with this solution. (Be careful of using other cleaners to avoid possible chemical reactions.) For safety and maximum effectiveness, use the solution immediately after dilution.
 - b. Now using just water gently rinse the same parts. Again, **DO NOT TOUCH OR PUT WATER ON THE EVAPORATOR.**
8. Reinstall the evaporator cover.
9. Turn power on – press power on/off button. The machine will begin making ice
10. Discard the first 2 harvests of ice, which will take around 60 minutes. Your ice maker is now clean and ready to make ice again.

CARE AND MAINTENANCE

POWER FAILURE PROCEDURES

Most power failures are corrected within a few hours and should not affect the temperature of your ice maker if you minimize the number of times you open the ice maker door. If the power is going to be off for a longer period of time, take the proper steps to disconnect your appliance.

NOTE: When the ice maker is operating, the evaporator is only component that is cold to make ice. A power failure will only impact the machine making ice. The ice in the bin would slowly melt as normal.

EXTENDED PERIODS OF NON-USE



ELECTRICAL SHOCK HAZARD

WARNING Always disconnect power at the source before working on the unit.

NOTE: Do not winterize this unit with ANY type of anti-freeze; damage to the internal coating will occur, invalidating the warranty and creating a potential health hazard.

1. Turn off the water at the main water supply.
2. Disconnect the water supply line from the water inlet of the ice maker.
3. Remove any remaining ice from the storage bin.
4. Unscrew the drain nut of the water trough to drain the water into the bin, then let the remaining water drain out through the drain hole on the bottom of the bin. For models with a drain pump, listen for the pump to turn on and run, draining the remaining water. If you do not hear the drain pump run, pour some more water into the ice bin to trigger the pump to turn on. Once the pump has turned on, run, and then turned off, the water is sufficiently drained.
5. Turn the unit off and unplug the power cord.
6. Leave the door propped open to allow for circulation to prevent mold and mildew.
7. Leave the water supply line disconnected, and the power cord unplugged until ready for use.

NOTICE: Never pull on the power cord to unplug the appliance from the electrical outlet. Grasp the plug of the power cord and pull out firmly.

CARE AND MAINTENANCE

RECOMMISSIONING THE UNIT

1. If stored outside, it is recommended that the unit be thoroughly inspected to remove any dirt or debris as well as for animals/insects. **NOTE:** The unit cannot be directly exposed to water or elements such as snow or ice.
2. Connect the water supply line, turn on the water, check for leaks, and then restore power to the unit.
3. It is recommended to clean the unit after long-term storage.

STARTING UP THE UNIT

1. Turn on the water, check for leaks, and then turn on power.
2. Turn on the unit by pressing the power button.
3. The water inlet valve will turn on immediately to supply water to the unit. The water pump and compressor will turn on later (approximately 5 minutes) to initiate the ice making cycle. If the machine was shut off while in the ice-harvesting cycle, make sure the ice is harvested before starting up the unit.
4. The first harvest of ice should occur within 60 minutes of start-up.
5. After the unit purges air from the lines, normal harvesting and refilling occur every 40 minutes or less, under normal conditions.

TROUBLESHOOTING

BEFORE CALLING FOR SERVICE

If the unit appears to be malfunctioning, read through the operation section of this manual first. If the issue persists, check the troubleshooting guide on the following pages. Some of the problems mentioned in the troubleshooting guide can be solved easily without a service call.

FAULT ALARM AND ERROR CODES

When the unit detects error, it will sound the alarm with the ALARM indicator flashing and display the below error codes. Please provide the error codes when contacting customer service.

FAULT ALARM	ERROR CODES
Evaporator temperature sensor failure	E1
Condenser temperature sensor failure	E2
Ice full temperature sensor failure	E3
Long harvest alarm	E4
Low water alarm	E5
Long ice making alarm	E6
Drain pump failure	PUE
High ambient temperature	HIC

The ice maker will keep running on E1, E2 error with the RUN indicator flashing, and will completely stop working on the rest of errors.

TROUBLESHOOTING

ISSUE	POSSIBLE CAUSE	POSSIBLE SOLUTION
The machine won't operate.	The ice maker is unplugged.	Plug the ice maker in.
	The ice maker power switch is OFF.	Verify that the control unit is properly programmed.
	The ice storage bin is full of ice.	Remove some of the ice.
The compressor works abnormally with a buzzing noise.	The voltage is lower than recommended.	Stop the ice maker and do not restart until the voltage is normal.
The water doesn't feed in after the ice maker starts. (Possible error codes E4/E5)	The water supply tap is turned off.	Turn on the water supply tap.
	The water supply pipe is not properly connected.	Reconnect the water supply pipe.
	The water filter is not installed or not installed correctly.	Check that the water filter is installed correctly.
	Water inlet valve malfunction.	Contact ZLINE Customer Service at 1-614-777-5004 for assistance.
Machine makes ice, but at a very slow rate. (Possible error code HIG)	The condenser may be dirty.	Clean the condenser.
	The air flow to the ice maker may be obstructed.	Check the installation to ensure the air flow to the ice maker is not blocked.
	The ambient temperature and water temperature are high, or the unit is near some heat source.	Check the installation to ensure the ambient temperature is in the proper range.

TROUBLESHOOTING

ISSUE	POSSIBLE CAUSE	POSSIBLE SOLUTION
Water is leaking out of the unit. (Possible error codes E4/E5)	A few water droplets are on the door.	Under some conditions, humidity may condense on the door. Consider moving the unit or just be more careful when you open the door.
	The water supply connection is leaking.	Tighten water supply hose-fitting.
	Incorrect filter installation.	Check that the water filter is installed correctly.
Cubes are partially formed and are white at the bottom. (Possible error codes E4/E5)	There is not enough water in the water bin.	Check if the water supply pressure is below 20 psi.
		Check the water supply. It may be restricted.
		Check for a water leak at the water trough.
Noise during operation.	The feet are not leveled.	Level the feet. See "Leveling the unit" on page 11.
	Certain sounds are normal.	See "Expecting normal sounds" on page 25.
The ice made is too large and has pieces sticking together.	The water temperature in the storage tray or ambient is too low.	Stop the machine and reset the ice making cycle.
		Restart the machine after turning it off.
Conditions for ice making cycle are right but no ice is made.	The refrigerant leaks and/or the sealed system is blocked.	Contact ZLINE Customer Service at 1-614-777-5004 for assistance.
	Water pressure is not properly set.	The recommended water pressure is 58 psi. Pressures must not fall below 20 psi and static pressure must not exceed 80 psi.

TROUBLESHOOTING

ISSUE	POSSIBLE CAUSE	POSSIBLE SOLUTION
The ice maker stops suddenly while making ice.	The electricity is off.	Reconnect the power supply line.
	The room temperature is out of the stated range.	Cut off the electricity and let the ice maker stop working until the temperature returns within the stated range.
The body of the ice maker is electrified.	The ground line is not in the sockets.	Use the correct plug and outlet.
Scale builds up quickly inside the machine.	The calcium level in the water is too high.	Use a water-softening apparatus installed in front of the water inlet valve.

WARRANTY

COVERAGE

ZLINE Kitchen and Bath ("ZLINE") ice makers have a two year parts and service warranty and a five year parts warranty on the unit's sealed cooling system.

ZLINE warranty periods begin from the original date of product delivery and solely cover the original purchaser of the product, delivered new and in its original carton. The limited warranty covers all parts and labor for necessary repairs if any part of the product, or the product itself, proves to be defective in materials or workmanship.

The product must be deemed serviceable via troubleshooting with the ZLINE Customer Experience team. All service on ZLINE products under warranty must be performed by ZLINE-approved and ZLINE-certified service providers unless otherwise specified by ZLINE. Service will be provided during normal business hours.

Products must be unobstructed and accessible to the service provider at the time of service. ZLINE's liability is limited to the original purchase price of the product. Additional injuries, losses, damages, or other inconveniences caused by product malfunction or defects in materials are not covered under the terms of this warranty.

TERMS

ZLINE warranties apply only to the original purchaser of a ZLINE product installed for normal residential use. This is defined as a single-family, residential dwelling in a non-commercial setting. Any warranty claim stemming from installation, operation, or any other use within a commercial setting is not covered under this limited warranty. Commercial settings include, but are not limited to: schools, churches, hotels, restaurants, vacation rentals such as Airbnb, daycare centers, private clubs, fire stations, common areas in multi-family dwellings, nursing homes, food service locations, and institutional food service locations such as hospitals or correctional facilities.

This warranty is non-transferable and will not under any circumstance be extended based on the date of installation — the warranty period takes effect from the date of delivery and only covers the original purchaser. The warranty applies only to products installed in the contiguous United States and the District of Columbia.

WARRANTY

Failure to secure certified warranty service per these terms will result in a forfeiture of the remaining warranty. Out-of-pocket payments will not be reimbursed unless prior approval is received from ZLINE and/or ZLINE-certified service contract partners. Unapproved out-of-pocket payments for service will not be reimbursed. All warranty procedures must be followed to maintain warranty coverage.

If a product qualifies within the service window provided under these warranty terms, and ZLINE is unable to repair the product or a defective part of the product after a reasonable number of attempts, ZLINE reserves the right to offer to replace the defective part or the product or provide the original purchaser a full refund of the purchase price of the product (not including installation, removal, or other charges that were not included in the original purchase price).

The original purchaser of the product must provide the original proof of purchase, including the purchase date, when filing a claim to obtain replacement parts, service, or refunds. Additionally, the original purchaser of the product must provide the serial number of the product when filing a claim to obtain replacement parts, service, or refunds.

This warranty shall not apply to any ZLINE product in which the original factory serial number has been removed, altered, or cannot be readily determined for any reason. Further, ZLINE is not responsible for damage resulting from, but not limited to: shipment, delivery, or improper installation; negligence or improper maintenance, misuse, or abuse of the product; unauthorized alteration, modification, or tampering with the product; accident, fire, floods, pest infestations, pandemics, natural disasters, or any other unpreventable or unexplained acts of nature, commonly referred to as "acts of God"; flare-up fires or damages caused by improper electric supply, electrical line current, voltage, or power surges; and service to correct installation not in accordance with the instructions contained in ZLINE's product manuals and/or with local government codes.

In the event service is dispatched, and it is discovered that the reported issue is not covered under warranty based on the disclaimers above, the customer will be responsible for all service fees. Failure to pay these fees will result in the forfeiture of remaining warranty coverage.

WARRANTY

Information contained within ZLINE's installation and user manuals, in addition to product information included on ZLINE's website and all related digital listings, do not cover every possible condition and situation that may occur during the installation or operation of ZLINE products.

ZLINE reserves the right to make changes at any time to its products when considered safe, necessary, and useful. Always check the ZLINE website for the most up-to-date version of its product manuals: www.zlinekitchen.com/pages/manuals.

Do not install or operate any ZLINE product if it has missing or broken parts or if it arrives damaged due to shipping. If ZLINE products arrive damaged, contact ZLINE Customer Experience at 1-614-777-5004 for help. Failure to report a damaged appliance prior to installation or operation may void the warranty.

ZLINE disclaims responsibility for damage or injury caused by improper installation or use of any of its products. ZLINE is under no obligation, by law or otherwise, to provide concessions, including repairs, prorates, rebates, discounts, or replacements, once the warranty has expired.

SERIAL NUMBER LOCATION

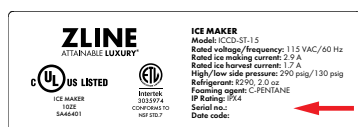
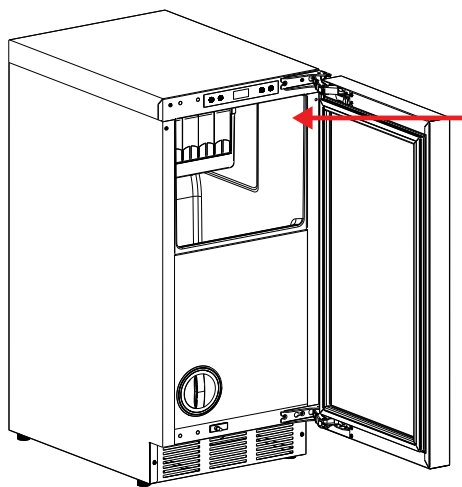

Please write down the model number and serial number of your appliance. The model number and serial number are located on the rating label, which is visible the right side of the cabin when the door is open. Both numbers are needed to obtain warranty service. Do not remove permanently affixed labels, warnings, or plates from the product. This will void the warranty. You may also consider attaching your receipt or proof of purchase to this manual.

WARRANTY



SERVICE

For warranty service, please contact our Customer Service team at 1-614-777-5004 or visit www.zlinekitchen.com/contact to utilize our online Customer Experience Portal.



Scan the QR code to view the most up-to-date version of our Installation Manual and User Manual.



Need to purchase a part or accessory for your ZLINE product? Visit www.zlineparts.com, ZLINE's official parts distribution partner.

1.3.4

zlinekitchen.com

1-614-777-5004

contact@zlinekitchen.com

ZLINE
ATTAINABLE LUXURY®