

GE Monogram® 12" Black Built-In Compactor with Reversible Panel and Safety Lock with Key



Model# ZCG3100VBB



FEATURES

Compression Ratio (Avg.)	75% Reduction or 4:1
Motor Horsepower	1/3 hp
Ram Force (lb.)	5000 lbs.
Automatic Anti-Jam	Yes
Lock/Start Control w/Removable Key	Yes
Slide-Out Drawer	Yes
Adjustable Front Leveling Legs	Yes
Bag Caddy	Yes

- 1/3 - Horsepower Motor
- 5,000-lb. Maximum Compacting Force
- Automatic Anti-Jamming Feature
- Slide-Out Compactor Drawer
- Lock/Start Control with Removable Key
- Adjustable Toekick
- Decorative Panel Options

To locate a GE Monogram dealer, call 1-800-626-2000

GE Monogram® 12" Black Built-In Compactor with Reversible Panel and Safety Lock with Key



Model# ZCG3100VBB

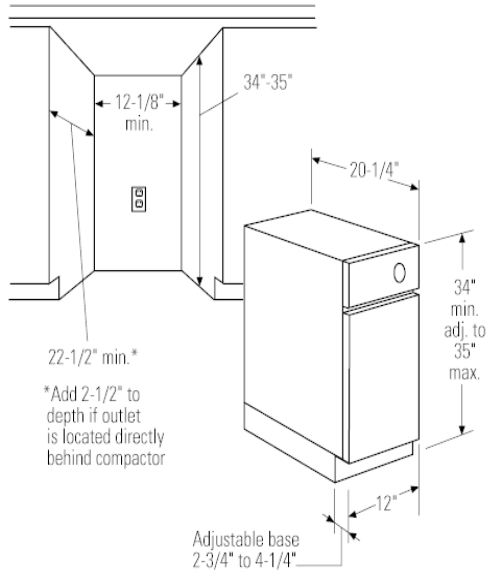

APPROXIMATE DIMENTIONS (HxDxW)

- 35 in x 20 1/4 in x 12 in

WARRANTY

- Parts Warranty - Limited 1-year entire appliance
- Labor Warranty - Limited 1-year entire appliance
- Warranty Notes - For models produced on or after January 1, 2006

See written warranty for full details