

# LIEBHERR

## Use and Care Manual

Cigar storage unit



XS 200  
7082 643-00

## **Thank you for your trust**

Congratulations on your purchase of this cigar storage unit. In buying this product, which is distinguished by its perfect user-friendliness, impeccable reliability and high quality, you have chosen a top class appliance. We hope that you enjoy your new cigar storage unit - and that you get a lot of pleasure from your exclusive cigars.

The features on your appliance have been designed to ensure maximum convenience - day in, day out.

This appliance has been manufactured with recyclable materials using an environmentally friendly process, so together we're making an active contribution to the preservation of our environment.

Please read the information in the operating instructions carefully to become familiar with all the benefits of your new appliance.

We know you will be pleased with your new appliance.

### **Additional benefits**

- CFC-free
- Energy-optimized refrigerant circuit
- Energy-efficient insulation
- Low energy consumption
- User-friendly electronic controls
- Display of functions switched on
- Temperature can be controlled within climate rating range, regardless of room temperature
- Audible door open alarm
- Easy to clean

## **Optimum humidity and temperature are key.**

The very best humidors keep cigars at an even and constant relative humidity. Experts put the ideal level at 68-75% at an interior temperature of between 61 and 68°F. These climatic conditions allow the characteristic flavours of the cigar to unfold, the cigar will burn evenly and your enjoyment of the cigar and its taste will be enhanced. With the Liebherr cigar storage unit you can ensure constant humidity and a constant temperature - and control each one individually.

## **Naturally Spanish cedarwood.**

The interior fittings of the Liebherr cigar storage unit are made of Spanish cedarwood. This top quality wood is used for the shelves and presentation boxes. Spanish cedarwood is used because it ensures an even climate inside the appliance, it helps the cigars to mature and its aroma enhances the unique flavour of exclusive cigars.

# TABLE OF CONTENTS

---

Keep these operating instructions in a safe place and pass them on to the next owner, where applicable.

<b>Contents</b>	<b>Page</b>
Safety .....	4
Disposal of Old Appliance .....	4
Electrical Safety .....	5
Important Safety Information .....	5
Safety Regulations.....	6
Unpacking .....	6
Safety Instructions and Warnings.....	6
Disposal of Carton .....	6
Wall mounting .....	6
Features .....	7
Dimensions .....	7
Leveling the appliance .....	7
Description of Appliance and Equipment .....	7
Operation.....	8
Operating and Control Elements .....	8
Switching on for the first time .....	8
Setting the Temperature.....	9
Adjusting the humidity.....	9
Lighting.....	9
Audible Warning Signal.....	9
Setup mode.....	10-11
Equipment .....	12
Equipment.....	12
Alternative interior layouts .....	13
Cleaning .....	14
Troubleshooting.....	15
Customer Service .....	15
Warranty .....	16
Appliance Information .....	16

## **IMPORTANT INFORMATION**

*After starting the appliance for the first time, allow it to reach the set temperature and humidity points before adding any cigars. It may take up to 24 hours to reach the set points.*

## **IMPORTANT**

*All types and models are subject to continuous improvement. The manufacturer reserves the right to make modifications in the shape, equipment and technology.*

# SAFETY

---

## Please read and follow these instructions

These instructions contain Warning and Caution statements. This information is important for safe and efficient installation and operation.

Always read and follow all Warning and Caution statements!

### DANGER

Danger indicates a hazard which will cause serious injury or death if precautions are not followed.

### WARNING

Warning indicates a potentially hazardous situation which, if not avoided, could result in death or serious injury.

### CAUTION

Caution indicates a potentially hazardous situation which, if not avoided, may result in minor or moderate injury.

### **IMPORTANT**

This highlights information that is especially relevant to a problem-free installation and operation.

Make sure incoming voltage is the same as the appliance rating.

To reduce the risk of fire, electric shock, or personal injury, installation work and electrical wiring must be done by a qualified electrician in accordance with all applicable codes and standards, including fire-rated construction.

## Disposal of Old Appliance

### DANGER

**Risk of child entrapment. Before you discard your old refrigerator or freezer:**

- Be sure to follow your local requirements for disposal of appliances. Discarded appliances can be dangerous.
- Remove the doors.
- Leave the shelves in place so that children may not easily climb inside.
- Cut off the power cable from the discarded refrigerator. Discard separately from the refrigerator.

Following these instructions reduces the possibility of causing personal injury, especially to children playing.

Contact the trash collection agency in your area for additional information.

## Electrical Safety

Connect this appliance to a 110-120 VAC, 15 amp circuit that is controlled by a circuit breaker or fuse. This appliance should have its own separate grounded circuit. Do not use an extension cord.

The power cord is equipped with a three-prong (grounding) plug for your protection against possible shock hazards. To maintain this protection:

- Do not modify the plug by removing the round grounding prong.
- Do not use a two-prong adapter. Where a two-prong wall receptacle is encountered, contact a qualified electrician and have it replaced with a three-prong receptacle in accordance with all local codes and ordinances.
- Do not use a power cord that is frayed or damaged.

## Important Safety Information

Follow the cautions and safety warnings throughout this instruction manual including the following:

- To prevent injury to you or damage to the unit, the appliance should be unpacked and set up by two people.
- If the appliance is damaged on delivery, contact the supplier immediately before connecting to the power source.
- To guarantee safe operation, ensure that appliance is set up and connected as described in these operating instructions.
- Disconnect the appliance from the power source if a fault occurs. Pull out the plug, turn off or disable the power source.
- When disconnecting the appliance, use the plug. Do not pull on the cord.
- Any repairs and work on the appliance should only be performed by the customer service department. Unauthorized work may be dangerous to the user. Changing the power source cable should only be done by the customer service department.
- Do not store explosives or sprays using combustible propellants such as butane, propane, pentane, etc. in the appliance. Electrical components might cause leaking gas to ignite. You may identify such sprays by the printed contents or a flame symbol.
- Do not use electrical appliances inside the appliance.
- Do not allow children to play with the appliance. Children must not climb, sit or stand on the racks or door.
- To prevent possible injury due to an electrical shock, be sure to disconnect the power cord or turn off the circuit breaker before cleaning the appliance.
- To avoid injury or damage to the appliance, do not use steam cleaning equipment to clean the appliance.
- Do not operate the appliance in the presence of explosive fumes.
- In the event of a power outage, minimize opening the door.
- To protect the appliance from possible damage, allow the appliance to stand 1/2 to 1 hour in place before turning the electricity on. This allows the refrigerant and system lubrication to reach equilibrium.

## Safety Regulations

The appliance is designed for storing cigars only. It is designed as a household appliance.

The appliance is set to operate within specific ambient temperature limits according to its climate rating. These temperature limits should not be exceeded. The correct climate rating for your appliance is indicated on the model plate.

This is explained as follows:

Climate Rating	Set for Ambient Temperatures of
SN	50°F to 90°F (10°C to 32°C)
N	61°F to 90°F (16°C to 32°C)
ST	61°F to 100°F (16°C to 38°C)
SN-ST	50°F to 100°F (10°C to 38°C)
SN-T	50°F to 109°F (10°C to 43°C)
T	61°F to 109°F (16°C to 43°C)

- The refrigerant circuit has been tested for leaks.
- The appliance complies with current safety regulations UL250 and CSA C22.2 #63.

We recommend cleaning the appliance before turning it on for the first time. See **Cleaning**.

### **WARNING**

**Do not allow children to play with the appliance. Children must not climb, sit or stand on the racks or door. Failure to follow these instructions may result in death or serious injury.**

# UNPACKING

## Safety Instructions and Warnings

Avoid placing the appliance in direct sunlight or near the stove, range top, radiators and similar heat sources. Do not place microwave ovens, toaster ovens or other heat-emitting appliances on top of this unit.

Keep the appliance out of the weather. The ventilation grilles should not be obstructed. Always ensure there is good ventilation all around the appliance.

As soon as you uncrate the unit:

- Examine the unit and packaging for shipping damage. Contact the carrier immediately if you suspect there is any damage.
- Note the type (model number), service number, serial number, date of purchase and where purchased on the spaces provided in the back of this manual.

## Disposal of Carton

The packaging is designed to protect the appliance and individual components during moving and is made of recyclable materials.

- Corrugated board/cardboard
- Molded polystyrene (foamed, CFC-free polystyrene)
- Polythene bags and sheets
- Polypropylene straps

### WARNING

**Keep packaging materials away from children. Polythene sheets and bags can cause suffocation!**

- Please take the packaging material to your local recycling facility.

## Wall mounting - Figure 1

The appliance can be wall-mounted. There are two mounting holes **1** at the back of the appliance.

### CAUTION

**Make sure the wall and fastenings can withstand the weight of the appliance when fully loaded. The empty appliance weighs 68.4 lbs.**

### IMPORTANT

To ensure sufficient ventilation through the ventilation slots, the four wall spacers **2** must always be inserted, regardless of whether the appliance is wall-mounted or standing on the floor against a wall.

Simply insert the spacers in the openings provided.

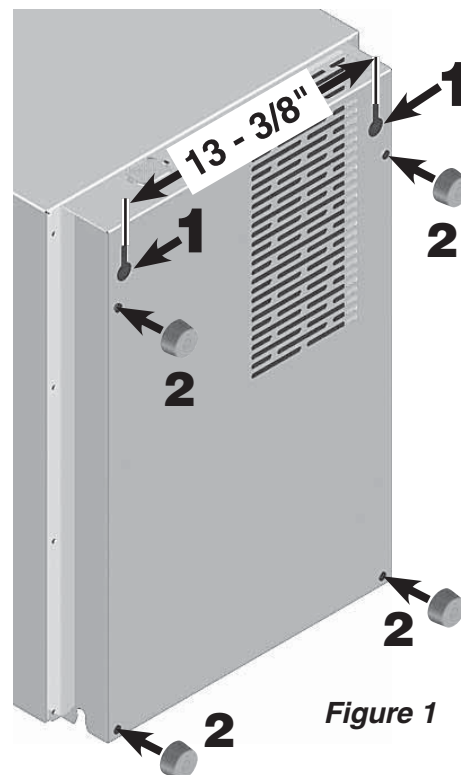

# FEATURES

## Dimensions - Figure 2

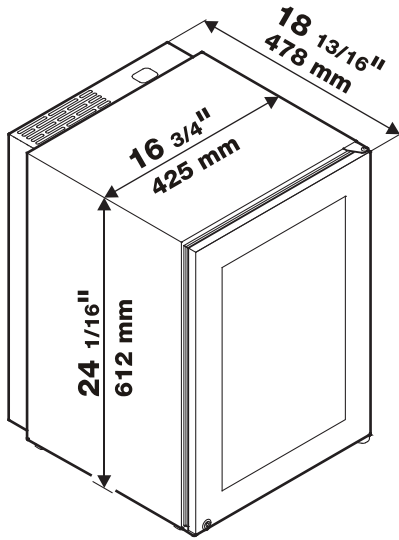

Figure 2

## Leveling the appliance - Figure 3

The floor should be level and even. You can compensate for an uneven floor surface by turning the adjustable feet.

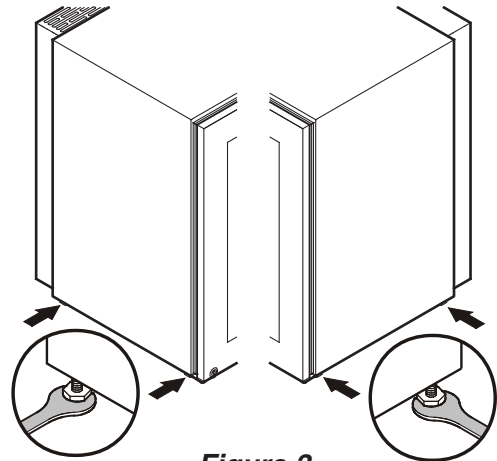

Figure 3

## Description of appliance and equipment - Figure 4



### Note

The type plate is located on the rear of the appliance.

Pull-out shelves for storing cigars in containers

Presentation boxes for individual cigar storage

Operating and control elements

Water tank behind front flap

Figure 4

# OPERATION

## Operating and Control Elements

### - Figure 5

The electronic control panel has the new “**Touch capacitance technology**”. Any function can be activated by a fingertip on the symbol of the operating icons.

The exact contact point is between the Symbol and its label .

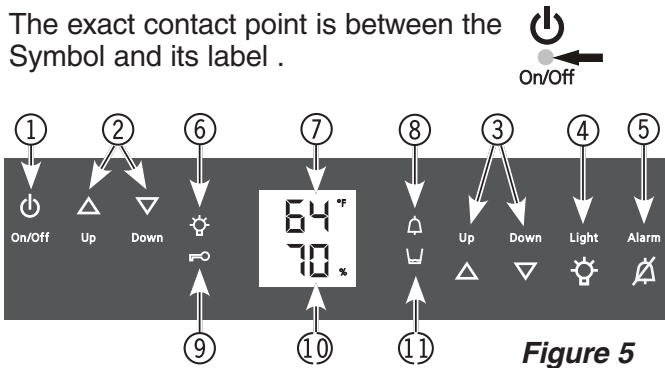

Figure 5

- ① Appliance ON/OFF
- ② Temperature setting buttons (for setting the interior temperature)
- ③ Humidity setting buttons (for setting the interior humidity)
- ④ Interior light ON/OFF
- ⑤ Mute alarm
- ⑥ Interior light On LED
- ⑦ Temperature display
- ⑧ Alarm LED (flashes to indicate a malfunction)
- ⑨ Child lock LED
- ⑩ Humidity display
- ⑪ Top up water tank

💡 LED lights up when the lighting is switched on.

🔒 LED lights up when the child lock is active.

🔔 LED flashes when the temperature or humidity inside the appliance is too high or too low.

🚰 LED lights up when the water tank needs topping up.

### Important!

This alarm will activate when the water level drops to 13 oz (sufficient to allow the appliance to run properly for another 6 weeks). When topping up the water, always remove any impurities such as cigar leaves. If the water tank is very dirty, clean it and refill.

## Switching on for the first time

Before switching on the appliance, fill the water tank with 32 oz of distilled water.

**Use distilled water only!**

Fold down the front flap completely and if necessary slide it into the appliance as far as it will go (**Figure 6**).

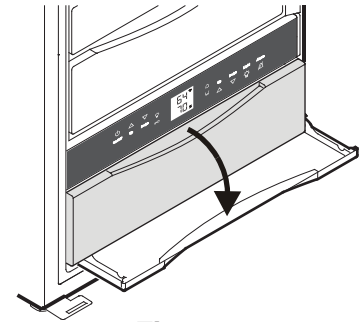

Figure 6

Lift the water tank slightly, remove and fill with water (**Figure 7**).



Figure 7

Replace the water tank, sliding it in as far as it will go. Pull out the front flap completely and fold upwards at a 90° angle.

**To switch on:** Press the **On/Off** button. The display will flash.

The appliance will take 24 hours to reach the correct level for storing cigars (temperature, humidity).

The factory setting is 64°F and 70% humidity.

**To switch off:** Press the **On/Off** button for 3 seconds until the display goes dark.



## Setting the Temperature - Figure 8

To reduce the temperature: Press the **Down** button.

To increase the temperature: Press the **Up** button.

- While you are entering the temperature, the set temperature will flash on the display.
- The electronic controls will switch over automatically about 5 seconds after the last time you pressed the button, and the actual temperature will be displayed.

The temperature can be set at between 61°F and 68°F.

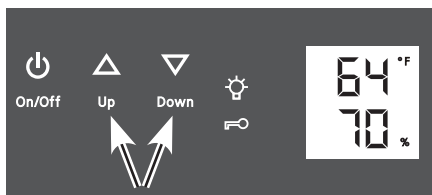

Figure 8

## Adjusting the humidity - Figure 9

To reduce the humidity: Press the **Down** button.

To increase the humidity: Press the **Up** button.

- While you are setting the humidity, the display will flash.
- About 5 seconds after the button was last pressed, the actual interior humidity will be displayed.

The humidity can be adjusted between 68% and 75%.

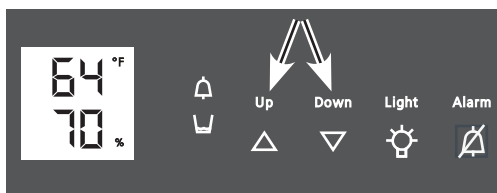



Figure 9

## Lighting

The light is integrated into the door frame and can be switched on and off by pressing the **Light** button (Figure 10).

The  symbol lights up when the light is switched on (Figure 10).

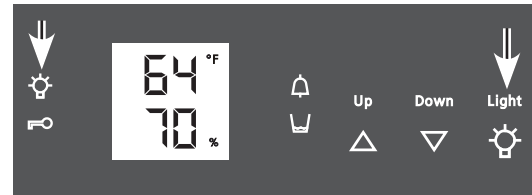

Figure 10

Furthermore, the brightness of the lighting can be adjusted (Figure 11).

Press and hold the **Light** button and at the same time press the humidity setting buttons to increase or decrease the brightness.

Down = darker , Up = brighter

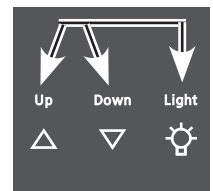

Figure 11

## Audible Warning Signal - Figure 12

The audible warning signal sounds in the event of a malfunction.

It sounds when the door has been left open for longer than 60 seconds.

It will also sound if the interior becomes too cold or too warm or if the humidity is too high or too low. The corresponding display will also flash.

The  symbol lights up.

The audible warning device is switched off by pressing the **Alarm** button.

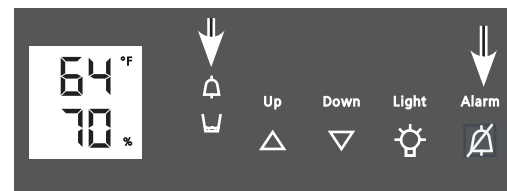

Figure 12

# OPERATION

## Setup Mode - Figure 13

In the setup mode you can activate the following functions:

- ☰ = Sabbath mode
- h = Display brightness
- ☐ = Temperature display mode
- ☒ = Child lock

### How to activate the setup mode

- Press the **Light** button for approximately five seconds
- after 5 seconds ☰ will flash in the display.

You can select the setup mode functions by pressing the **Up/Down** buttons.

### Exit setup mode

- Press the **On/Off** button. The appliance will change back to normal operation.

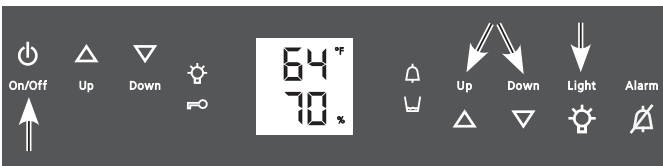

Figure 13



## ☰ = Sabbath Mode

This feature considers the Religious requirements on Sabbath or Holidays. When the Sabbath Mode is active some functions of the electronic controls are switched off.



### The door can be opened and closed at any time.

- The lighting remains off.
- The cooling fan remains in its actual state: If it is on it remains on, if it is off it remains off.
- There is no door alarm.
- There is no temperature alarm.
- The unit will return into Sabbath Mode after a power failure.

### How to activate the Sabbath Mode

- Activate the setup mode by pressing the **Light** button for 5 seconds.
  - the display shows ☰
- Press the **Light** button
  - the display shows 
- Press the **Light** button again
  - the display shows 
  - the Sabbath mode is activated.
- Exit setup mode by pressing the **On/Off** button.

### How to deactivate the Sabbath Mode

- Activate the setup mode by pressing the **Light** button for 5 seconds.
  - the display shows ☰
- Press the **Light** button
  - the display shows 
- Press the **Light** button again
  - the **S** symbol  in the Display disappears, the Sabbath mode is deactivated.
- Exit setup mode by pressing the **On/Off** button.

## h = Display brightness

### How to adjust the display brightness

- Activate the setup mode by pressing the **Light** button for 5 seconds.
- Press the **Down** button until **h** appears in the display.
- Press the **Light** button
  - the display shows 
- Press **Up/Down** buttons to select
  - h 0 = minimum to
  - h 5 = maximum brightness
- Press the **Light** button at the desired value.
- Exit setup mode by pressing the **On/Off** button.
- Close the door. The new setting will activate after about 1 minute.

## □ = Temperature display mode

You can choose the **unit of temperature** for the display in degrees Fahrenheit or degrees Celsius.

### Note

*The factory setting is degrees Fahrenheit.*

### How to change the temperature display to degrees Celsius

- Activate the setup mode by pressing the **Light** button for 5 seconds.
- Press the **Down** button until **□** appears in the display.
- Press the **Light** button
  - the display shows 
- Press the **Light** button again
  - the temperature reading is now displayed in degree Celsius.
- Exit setup mode by pressing the **On/Off** button.



### Note

*To change the temperature display back to degrees Fahrenheit, follow the steps above.*



## ⊔ = Child lock

The child lock is designed to protect the appliance from being turned OFF accidentally.

### How to activate the child lock

- Activate the setup mode by pressing the **Light** button for 5 seconds
- Press the **Down** button until **⊔** appears in the display.
- Press the **Light** button
  - the display shows 
- Press the **Light** button again
  - the LED  is lit and the child lock is activated.
- Exit setup mode by pressing the **On/Off** button.

### How to deactivate the child lock

- Activate the setup mode by pressing the **Light** button for 5 seconds.
- Press the **Down** button until **⊔** appears in the display.
- Press the **Light** button
  - the display shows 
- Press the **Light** button again
  - the LED  goes out. The child lock is deactivated.
- Exit setup mode by pressing the **On/Off** button.

# EQUIPMENT

## Equipment

### Spanish cedarwood shelves - *Figure 11*

The presentation boxes ② are designed for storing cigars individually.

The other shelves ① are for storing cigars in various containers or boxes.

All shelves are fitted with a pull-out stop and can be pulled out by 4" (100 mm).

To remove completely, pull the shelf out as far as it will go, lift slightly at the front and remove. The door must be open at an angle of at least 90°.

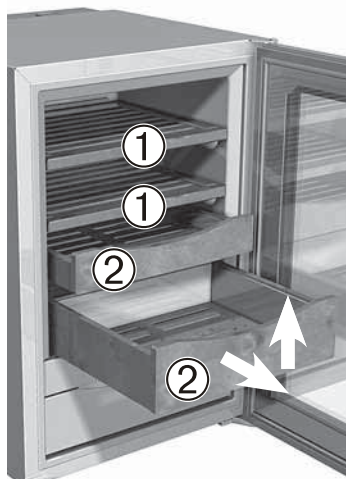

*Figure 11*

### Note

To ensure optimum operation, there must always be at least two cedarwood shelves or boxes inside the appliance, one of which must always be inserted immediately above the control panel.

### Air exchange with activated charcoal filter - *Figure 12*

To guarantee optimum air throughput, the appliance is fitted with an activated charcoal filter at the top of the rear wall.

We recommend that you replace the illustrated filter once a year. Filters can be obtained from your dealer.

### Changing the filter:

The filter can be removed by depressing the recesses on the left and right with a small screwdriver.

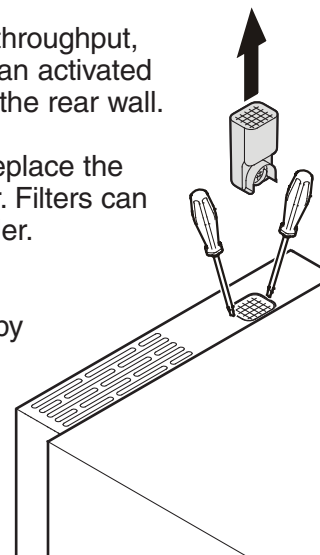

*Figure 12*

## Alternative interior layouts

The different fitting layouts for optimum cigar storage are illustrated and described below.

### Alternative 1 (as supplied) - *Figure 13*

Use this layout to store large numbers of cigars individually in the presentation boxes and small cigar boxes on the shelves.



*Figure 13*

### Alternative 3 (with both presentation boxes removed) - *Figure 15*

This layout is only suitable for storing large cigar boxes (see figure).



*Figure 15*

### Alternative 2 (with top shelf removed) - *Figure 14*

Use this layout to store large cigar boxes.



*Figure 14*

### *Important*

1. To ensure constant humidity, there must be at least two pull-out shelves or presentation boxes in the appliance at all times.
2. To ensure adequate air circulation there must always be a shelf or presentation box immediately above the control panel.
3. The pull-out shelves should only be used for storing cigar boxes. Do not use them for storing individual cigars!

# CLEANING

## Cleaning

### ⚠ WARNING

- To prevent possible injury due to an electrical shock, be sure to disconnect the power cord or turn off the circuit breaker before cleaning the appliance.
- To avoid injury or damage, do not use steam cleaning equipment to clean the appliance.
- To avoid short-circuits, ensure no cleaning water penetrates into the electrical components when cleaning the appliance. Do not use a sponge or cloth that is overly wet.

**Do not** use abrasive or scouring sponges. **Do not** use concentrated cleaning agents. **Never** use abrasive or acid cleaners or chemical solvents or steam cleaners.

- Remove all cigars from the appliance and store them in a suitable place.
- Remove all shelves and presentation boxes.
- Clean the inside, the door seal and the inside of the glass with a clean, damp cloth.

### **Important**

*Never use detergents or other substances that emit odours.*

- Always keep the door closed when cleaning the outside of the appliance. Make sure no detergent odours penetrate into the appliance.
- Clean the side panels and door surfaces with a clean and soft cloth. If necessary, use a moist cloth (water + detergent). Alternatively, use a microfibre cloth.
- Fold down the front flap, lift the water tank slightly and remove, as illustrated (**Figure 16**). This tray can be washed with water and detergent either manually or in a dishwasher. After cleaning, always make sure the tray is thoroughly rinsed with clean water before replacing.
- Dry the interior and the water tank thoroughly with a clean cloth and replace the water tank.
- Switch the appliance back on and replace the cigars.
- Do not damage the type plate on the back of the appliance. It is very important for servicing purposes.



**Figure 16**

Remove any dust from the outside of the ventilation grille (**Figure 17**) with a vacuum cleaner.

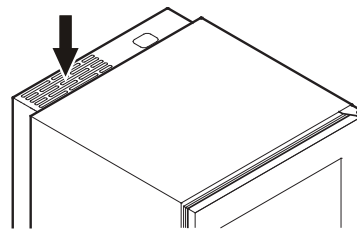

**Figure 17**

# TROUBLESHOOTING

Your appliance is designed and manufactured for a long life and reliable operation.

If a problem occurs during operation, check whether it is due to an operating error. Please note that even during the warranty period, some repair costs may be your responsibility.

You may be able to correct the following faults by checking the possible causes yourself:

Problem	Possible Cause and Remedy
Appliance does not work, display is off	<ul style="list-style-type: none"> <li>- Is the appliance turned on properly?</li> <li>- Is the power cord properly inserted in the outlet?</li> <li>- Is the circuit breaker or fuse in operating condition?</li> </ul>
Loud running noise	<ul style="list-style-type: none"> <li>- Is the appliance placed firmly on the floor. Please note that noises caused by the refrigerant circuit and fan noise cannot be avoided. The interior fan runs constantly.</li> </ul>
The temperature inside the appliance is too high	<ul style="list-style-type: none"> <li>- Is the temperature setting correct? See <b>Setting The Temperature</b>.</li> <li>- Is the ventilation system working properly?</li> <li>- Is the appliance set up too close to a heat source?</li> </ul>
The humidity inside the appliance is too low	<ul style="list-style-type: none"> <li>- Is there sufficient water in the water tank?</li> </ul>
The humidity inside the appliance is too high	<ul style="list-style-type: none"> <li>- Is the water tank inserted as far as it will go?</li> <li>- Is the seal seated properly against the water tray? You can check this visually from the front of the appliance. If the seal is not seated properly, remove the water tank and slide it back into the appliance.</li> <li>- If the humidity is too high, this could indicate a technical fault. Contact the customer service department and, as an interim measure, leave the door of the appliance open until the display returns to a normal value.</li> </ul>
<i>FB</i> appears in the display	The appliance has a fault. Contact your nearest customer service representative, indicate the type of appliance, service number and appliance / serial number.
Water level alarm lights up despite full water tank	<ul style="list-style-type: none"> <li>- Is the float gauge in the water tank stuck? Move it with a pointed object (<b>Figure 18</b>).</li> </ul>

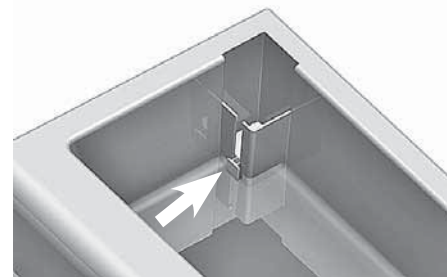

Figure 18

## Customer Service - Figure 19

If none of the above possible causes apply, and you can not rectify the fault yourself, contact your nearest customer service representative. Indicate the type **(1)** of appliance, service number **(2)** and the appliance / serial number **(3)** as indicated on the model plate. The model plate is located on the left-hand inside wall.

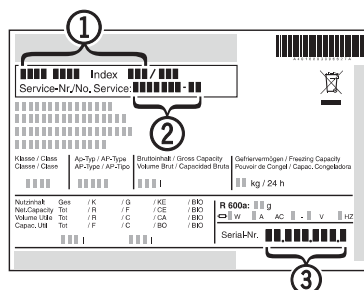

Figure 19

# WARRANTY

---

## LIEBHERR WARRANTY PLAN

**FULL TWO YEAR WARRANTY** - For two years from the date of original purchase, your Liebherr warranty covers all parts and labor to repair or replace any part of the product which proves to be defective in materials or workmanship.

**FULL FIVE YEAR WARRANTY** - For five years from the date of original purchase, your Liebherr warranty covers all parts and labor to repair or replace any components that prove to be defective in materials or workmanship in the sealed system. The "Sealed System" means only the compressor, condenser, evaporator, drier and all connecting tubing.

**LIMITED 6TH THROUGH 12TH YEAR WARRANTY** - From the 6th through 12th year from the date of original purchase, your Liebherr warranty covers all parts that prove to be defective in materials or workmanship in the Sealed System (parts only).

### TERMS APPLICABLE TO EACH WARRANTY

All service provided by Liebherr under the warranty must be performed by authorized Liebherr service representatives, unless otherwise specified by Liebherr. Service will be provided in the home during normal business hours. This warranty applies only to products installed for normal residential use. Details regarding a non-residential warranty are available on request.

The warranty applies only to products installed in Canada and any one of the fifty states of the United States or the District of Columbia. This warranty does not cover any parts or labor to correct any defect caused by negligence, accident or improper use, maintenance, installation, service or repair, including but not limited to improper removal and reinstallation of the condensing unit.

***The remedies described above for each warranty are the only ones which Liebherr will provide, either under these warranties or under any warranty arising by operation of law. Liebherr will not be responsible for any consequential or incidental damages arising from the breach of these warranties or any other warranties, whether express, implied or statutory.***

Some States do not allow the exclusion or limitation of incidental or consequential damages so the above limitation or exclusion may not apply to you. This warranty gives you specific legal rights and you may also have other rights which vary from State to State.

To receive parts and/or service and the name of the Liebherr authorized service representative nearest you, contact your Liebherr dealer or distributor or contact the Liebherr designated national service provider:

in the US: Liebherr@adcoservice.com, or call 1-866-LIEBHERR or 1-866-543-2437

in Canada: www.euro-parts.ca, or call 1-888-LIEBHERR, 1-888-543-2437.

## Appliance Information

Record this information when the appliance is installed.

Type Designation: \_\_\_\_\_

Service Number: \_\_\_\_\_

Appliance / serial number: \_\_\_\_\_

Date of Purchase: \_\_\_\_\_

Where Purchased: \_\_\_\_\_