



KITCHEN VENTILATION SYSTEMS



Wall Mount Hood

XOT48KS

The XOT48KS is the largest and most powerful member of the XOT series. Moving 1000 CFM at high speed and with the ability to recirculate when venting is not possible - the XOT48KS is ready to answer some of your most demanding design applications.



XOT48KS Spec

Wall Mount Hood

Model: XOT48KS

Size: 48"

Depth: 22"

Features and Benefits:

- 1000 CFM high velocity blower optimally removes Smoke, Grease and Odors.
- 3 speed push button controls.
- Three 50W Halogen Lights - Provide brilliant illumination over the cooking surface.
- Dimensions: 48" W x 22" D x 11" T
- Baffle Filters - Trap airborne smoke and grease particles. They can be easily be removed for dishwasher-safe cleaning.
- Mounting Height from cooking surface 27"-32".
- Sound level 2.0 - 8.0 Sones

Duct Options and Electrical Requirements:

- 8 inch round vertical duct
- Ductless Option for applications where no ducting is available
- AC 120v-60Hz (4.35amp)

Options:

- Optional recirculation kit available
48" Part # XORFK09

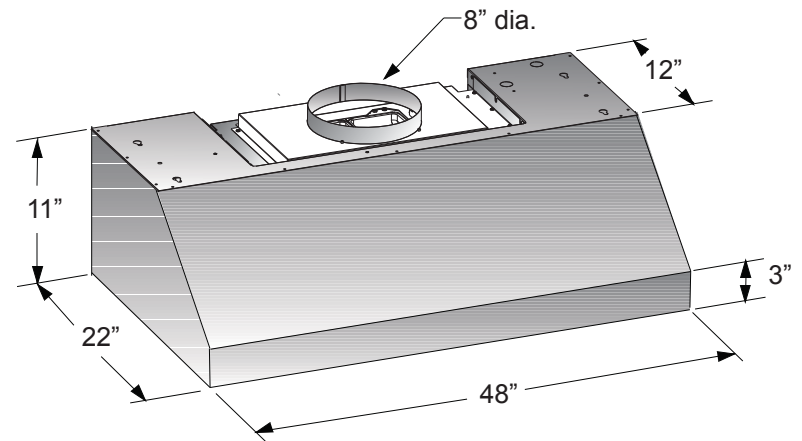

Photo below shown with recirculation kit.
Total height 13 1/4"



XO
www.xoappliance.com

XO is Exclusively Distributed by:
Eastern Marketing Corp 24 Eisenhower Parkway Roseland,
New Jersey 07068 800-966-8300
www.easternmarketingcorp.com

All XO hoods are UL approved. 

DESIGNED & CRAFTED IN
ITALY