

PRODUCT INSTALLATION AND SAFETY INSTRUCTIONS

MODELS : XOMA06, XOMA08

**READ ALL INSTRUCTIONS PRIOR TO
INSTALLATION
FOR RESIDENTIAL USE ONLY**

**WARNING: TO REDUCE THE RISK OF FIRE, ELECTRICAL SHOCK HAZARD,
OR INJURY TO PERSONS, OBSERVE THE FOLLOWING:**

1. Shut off and disconnect all power supply to unit(s) prior to installation or service/repair of device.
2. Use this unit only in manner intended by manufacturer.
3. All applications of device must follow all applicable laws, codes, regulations, and standards.
4. Installation of device must be completed by a certified installation expert or HVAC professional.
5. For residential use only, any use beyond factory recommendations voids all warranties.

Table of Contents

| | |
|---|-----|
| Product Safety | 1 |
| XOMA Technical Specifications..... | 2 |
| XOMA Install Instructions / Wiring Diagram..... | 2-3 |
| Warranty Information..... | 4 |

Parts Supplied for XOMA Series: each series /model sold as individual kit.

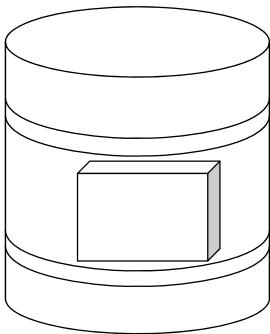

1 - XOMA* Switch Assembly
Patent Pending

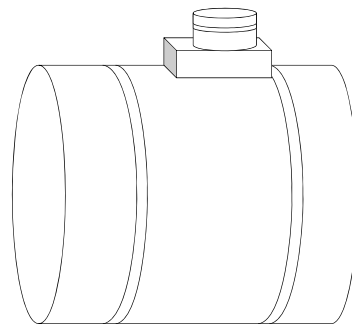

1 - XOMA* Motorized Damper

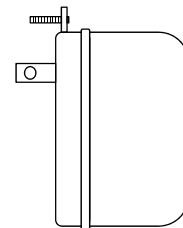

1 - 24V Plug-in
Power Transformer

*Diameter varies by model



Makeup Air System (XOMA)

Install and Dimensions Sheet – RESIDENTIAL USE ONLY

FOR PLANNING PURPOSES ONLY. PLEASE REFER TO INSTALL GUIDE FOR DETAILED INSTRUCTIONS

XOMA Switch Assembly and Collar Specifications:

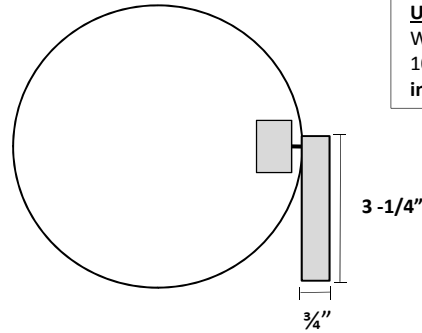
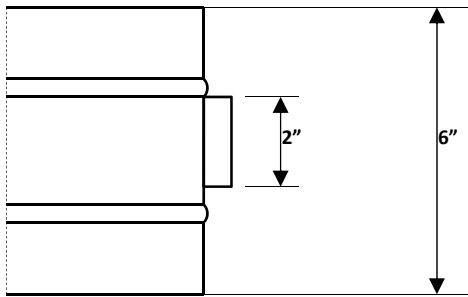

Unit Specifications
 Weight: 1.5 lbs, 16 AWG x 2, 10A, 125VAC. Refer to safety instructions prior to installation.

XOMA Motorized Fresh Air Damper Specifications:

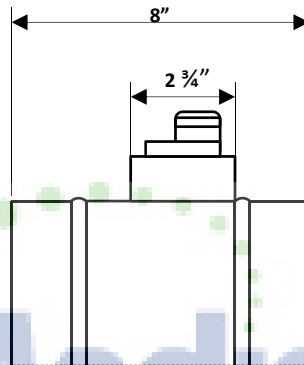
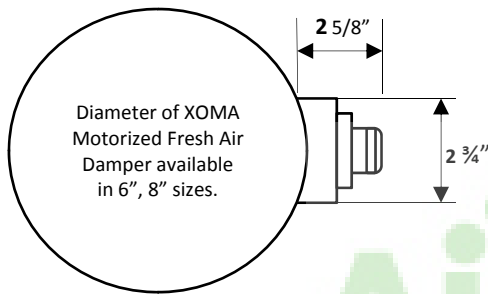

Unit Specifications
 Weight: 3 lbs.
 0.25 amps, 24 VAC, 60 HZ, 7 watts.
 Shipped in normally closed position.

24V low voltage wiring must be run at time of rough-in. (not included by manufacturer)

XOMA Fresh Air Damper in normally closed position

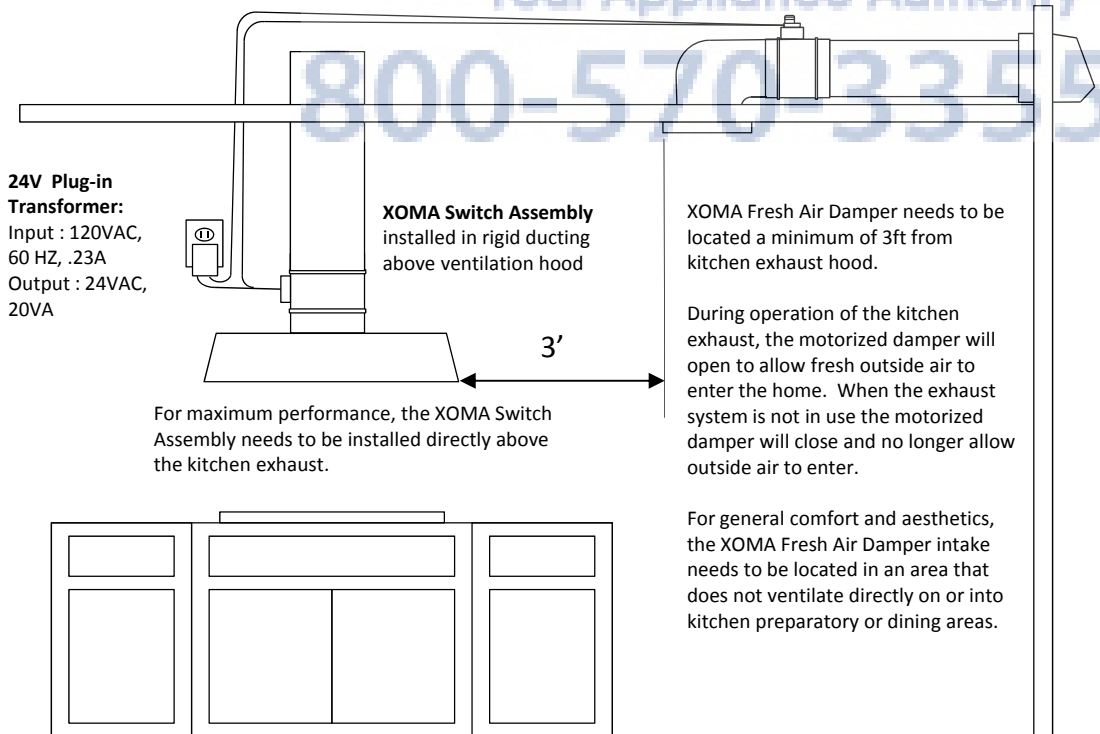

The replenishment or make-up air must be drawn from outside of the home.

Outside fresh air inlet must be installed on the exterior of the house a minimum distance of 10ft from combustion vents and other exhaust openings. Locate the fresh air inlet away from any outside motor, generator, pump, BBQ grill, hearth/fire pit, chemical storage area, or any potentially hazardous exposure area.

XOMA Fresh Air Damper needs to be located a minimum of 3ft from kitchen exhaust hood.

During operation of the kitchen exhaust, the motorized damper will open to allow fresh outside air to enter the home. When the exhaust system is not in use the motorized damper will close and no longer allow outside air to enter.

For general comfort and aesthetics, the XOMA Fresh Air Damper intake needs to be located in an area that does not ventilate directly on or into kitchen preparatory or dining areas.

Installation must be completed by a certified installation expert or HVAC professional and must follow all local, state, and federal HVAC codes, laws, standards, and regulations.

Installing the XOMA Switch Assembly:

No additional Electrical Wiring Required:
The 24V Transformer can be plugged into a 120V receptacle next to kitchen vent hood for a convenient and aesthetic install.

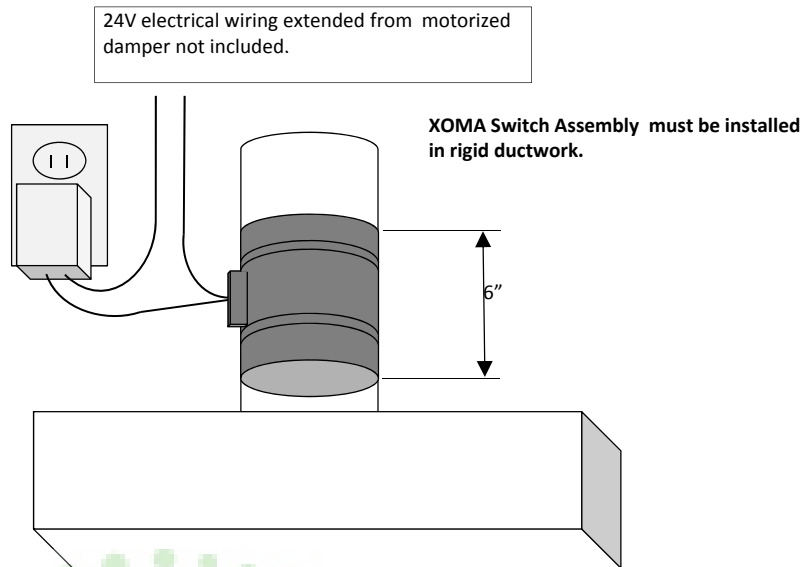

The recommended location for the XOMA Switch Assembly collar is in a straight duct run directly above the kitchen exhaust fan motor.

WARNING: TO REDUCE THE RISK OF FIRE, ELECTRICAL SHOCK HAZARD, OR INJURY TO PERSONS, OBSERVE THE FOLLOWING:

1. Shut off and disconnect all power supply to unit(s) prior to installation or service/repair of device.
2. Use this unit only in manner intended by manufacturer.
3. All applications of device must follow all applicable laws, codes, regulations, and standards.
4. Installation of device must be completed by a certified installation expert or HVAC professional.
5. For residential use only, any use beyond factory recommendations voids all warranties.

24V class 2 power transformer connects to motorized Fresh Air Damper wire terminals #1 and #2.

XOMA switch assembly connects to motorized Fresh Air Damper wire terminals #2 and #3.

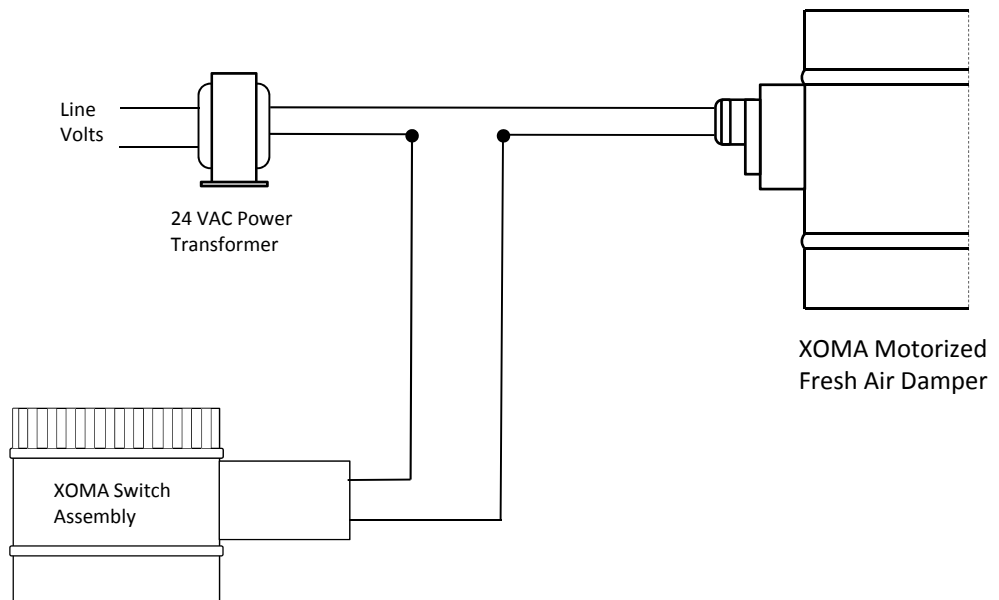



Makeup Air System (XOMA)

Install and Dimensions Sheet – RESIDENTIAL USE ONLY

LIMITED TWO YEAR WARRANTY:

XO Ventilation offers a limited two year parts only warranty for manufactured products from the original date of purchase. Warranty does not cover labor, removal of device, or installation of new device provided by manufacturer. All warranties voided by misuse of product, use beyond manufacturer's recommendations, non-residential use, or negligence by contractor or installer. Warranty only applies in the United States, any product sold or used outside of the United States will not be covered under manufacturers limited warranty.

ADDITIONAL ITEMS EXCLUDED FROM MANUFACTURERS LIMITED WARRANTY:

- Cosmetic damages not reported or claimed within 48 hours of original purchase
- Damage or failure resulting from accident, fire, flood, Acts of God, improper installation or installation not in accordance to applicable laws, codes, and regulations
- Any alteration or modification to original product or components beyond stated manufacturer's guidelines and recommendations

For product assistance please contact XO Ventilation Technical Support: 1-800-966-8300

800-570-3355