

**EVERY
THING
YOU NEED
TO KNOW
ABOUT YOUR**

XO

XOIL INSERT | LINER
MODELS XOIL4819KS

I worked really hard
on this manual -
so please read it...

XO



When buying any XO appliance you can be confident you have chosen a high quality, innovative and stylish product from a company that cares about you!

If you require service or have questions, there are 2 ways to contact our ventilation experts;

Online @ <https://xoappliance.com/priority-service-for-your-xo-product/>

Or by phone 973-403-8900



CONGRATULATIONS

on purchasing your XO.
Before you proceed, take just a moment to register your XO at:

www.xoappliance.com/register-your-product/

REGISTRATION HELPS YOU BY -

Ensuring warranty coverage should you need service

Providing ownership verification for insurance purposes

Let's XO notify you in the event of product changes or recalls.

WHERE THINGS ARE

GETTING READY

4 - 11

Safety and Precautions

Planning Ductwork

Install Examples

Dimensions

THE INSTALL

12 - 17

Mounting Height

Top or Rear Exhaust

Cut Out Dimensions

Installing

Electrical Connections

MAINTENANCE

18 - 19

Filters

Cleaning

Light Replacement

OPERATING

20

The Push Button Controls

Synchronizing the Remote

PARTS & WARRANTY

21 - 23

PLEASE READ AND FOLLOW
ALL SAFETY INSTRUCTIONS

It's for your
own good...
Honest.

XO

SAFETY FIRST

CAUTION - FOR RESIDENTIAL KITCHEN USE ONLY

Do Not Use to exhaust hazardous or explosive materials or vapors.

NEVER exhaust air into a confined space such as an attic, crawlspace, garage, soffit or voids between walls.

Ducted installation must exhaust outside. Recirculating installations must exhaust back into the living space.

WARNING: ELECTRICAL SAFETY

This appliance must be connected to a properly grounded, dedicated 120v 60hz 15amp circuit by a qualified electrician in accordance with all applicable codes and regulations.

Never use any external speed control device.

Never use any extension cord or temporary wiring.

Switch all power off before performing work, service or maintenance on the unit

The appliance must be protected by a properly sized circuit breaker or time delay fuse.

CAUTION - DURING INSTALLATION

All installation work and electrical wiring must be done by qualified people in accordance with all applicable codes and standards, including fire rated construction.

Sufficient air is required for proper combustion and exhausting of gases through the flue duct (chimney) of the fuel burning equipment to prevent backdrafting.

Follow the cooking equipment manufacturer's guidelines and safety standards such as those published by the National Fire Protection Association (NFPA) and the American Society of Heating, Refrigeration, and Air Conditioning Engineers (ASHRAE) as well as all local code authorities.

WARNING: TO REDUCE RISK OF A RANGETOP GREASE FIRE:

- a. Never leave the cooking surface unattended. Boil overs, spills and splatter may ignite or create smoke. Heat oils slowly on low or medium heat settings.
- b. Always turn the hood on before you begin cooking.
- c. Clean the hood frequently. Keep filters, fans and surfaces free of grease.
- d. Use pan sizes appropriate for each burner.e.prepared.
- e. Use high heat only when necessary.
- f. Use cookware and utensils designed for the cooking style, type and amount of food.

State of California Proposition 65 Warning (US only)

⚠ WARNING

This product contains chemicals known to the State of California to cause cancer and birth defects or other reproductive harm.

For more information go to www.P65Warnings.ca.gov

SAFETY FIRST CONTINUED

■ IMPORTANT SAFETY INSTRUCTIONS

■ FOR RESIDENTIAL USE ONLY

■ READ AND SAVE THESE INSTRUCTIONS

■ PLEASE READ ENTIRE INSTRUCTIONS BEFORE PROCEEDING.

■ **IMPORTANT:** Save these Instructions for the Local Electrical Inspectors use.

■ **INSTALLER:** Please leave these Instructions with this unit for the owner.

■ **OWNER:** Please retain these instructions for future reference.

■ Take care when using cleaning agents or detergents.

■ Suitable for use in household cooking area.

■ **WARNING** - To reduce the risk of fire or electric shock, do not use this fan with any Solid-State Speed Control Device.

■ **CAUTION** - To reduce risk of fire and to properly exhaust air, be sure to duct air outside – Do not vent exhaust air into spaces within walls or ceilings or into attics, crawl spaces, or garages.

■ **CAUTION** - For general ventilating use only. Do not use to exhaust hazardous or explosive materials and vapors.

■ **CAUTION** - To avoid motor bearing damage and noisy and/or unbalanced impellers, keep drywall spray, construction dust, etc. off power unit.

■ **CAUTION** - Please read specification label on product for further information and requirements.

■ **WARNING** – TO REDUCE THE RISK OF FIRE, ELECTRIC SHOCK, OR INJURY TO PERSONS, OBSERVE THE FOLLOWING:

A. Use this unit only in the manner intended by the manufacturer. If you have questions, contact the manufacturer.

B. Before servicing or cleaning unit, switch power off at service panel and lock the service disconnecting means to prevent power from being switched on accidentally. When the service disconnecting means cannot be locked, securely fasten a prominent warning device, such as a tag, to the service panel.

■ **WARNING - TO REDUCE THE RISK OF A RANGE TOP GREASE FIRE:**

A. Never leave surface units unattended at high settings. Boilovers cause smoking and

SAFETY FIRST CONTINUED

greasy spillovers that may ignite. Heat oils slowly on low or medium settings.

- B.** Always turn hood ON when cooking at high heat or when flambeing foods (i.e. Crepes Suzette, Cherries Jubilee, Peppercorn Beef Flambe).
- C.** Clean ventilating fans frequently. Grease should not be allowed to accumulate on fan or filter.
- D.** Use proper pan size. Always use cookware appropriate for the size of the surface element.
- E.** Keep fan, filters and grease laden surface clean.
- F.** Use high range setting on range only when necessary. Heat oil slowly on low to medium setting.
- G.** Don't leave range unattended when cooking.
- H.** Always use cookware and utensils appropriate for the type and amount of food being prepared.

■ **WARNING** – TO REDUCE THE RISK OF INJURY TO PERSONS IN THE EVENT OF A RANGE TOP GREASE FIRE, OBSERVE THE FOLLOWING:

- A.** SMOTHER FLAMES with a close-fitting lid, cookie sheet, or metal tray, then turn off the burner. BE CAREFUL TO PREVENT BURNS. If the flames do not go out immediately, EVACUATE AND CALL THE FIRE DEPARTMENT.
- B.** NEVER PICK UP A FLAMING PAN – You may be burned.
- C.** DO NOT USE WATER, including wet dishcloths or towels – a violent steam explosion will result.
- D.** Use an extinguisher ONLY if:
 1. You know you have a Class ABC extinguisher, and you already know how to operate it.
 2. The fire is small and contained in the area where it started.
 3. The fire department is being called.
 4. You can fight the fire with your back to an exit.

^aBased on "kitchen firesafety tips" published by NFPA.

Proper maintenance of the Range Hood will assure proper performance of the unit.

■ **INSTALLATION INSTRUCTIONS**

WARNING – TO REDUCE THE RISK OF FIRE, ELECTRIC SHOCK, OR INJURY TO PERSONS, OBSERVE THE FOLLOWING:

- A.** Installation work and electrical wiring must be done by qualified person(s) in accordance with all applicable codes and standards, including fire-rated construction.
- B.** Sufficient air is needed for proper combustion and exhausting of gases through the flue (chimney) of fuel burning equipment to prevent back drafting. Follow the heating equipment manufacturer's guideline and safety standards such as those pub

SAFETY FIRST CONTINUED

lished by the National Fire Protection Association (NFPA), and the American Society for Heating, Refrigeration and Air Conditioning Engineers (ASHRAE), and the local code authorities.

- C. When cutting or drilling into wall or ceiling, do not damage electrical wiring and other hidden utilities.
- D. Ducted fans must always be vented to the outdoors.
- E. This unit must be grounded.

■ **WARNING** - TO REDUCE THE RISK OF FIRE, USE ONLY METAL DUCTWORK.

■ **WARNING** - UNDER CERTAIN CIRCUMSTANCES DOMESTIC APPLIANCES MAY BE DANGEROUS.

- A. Do not check filters with hood working.
 - B. Do not touch the lamps after a prolonged use of the appliance.
 - C. No food must be cooked flambè underneath the hood.
 - D. The use of an unprotected flame is dangerous for the filters and could cause fires.
 - E. Watch constantly the fried food in order to avoid the cooking oil flares up.
 - F. Before performing any maintenance operation, disconnect the hood from the electrical service.
- The manufacturers will not accept any responsibility for possible damages, because of failure to observe the above instructions.

A FEW SIMPLE RULES TO PLAN YOUR DUCTWORK

THIS HOOD IS DESIGNED TO USE AN 8" ROUND DUCT -
IT MAY BE TRANSITIONED TO A 4" X 14" RECTANGULAR DUCT

NEVER REDUCE DUCT SIZE. UNDERSIZED DUCTING SEVERELY RESTRICTS
AIR FLOW AND HARMS PERFORMANCE.

(Example: the area of an 8" Duct is more than 75% larger than a 6" Duct)

KEEP DUCT RUNS AS SHORT AND STRAIGHT AS POSSIBLE.

AVOID USING FLEXIBLE METAL DUCTING IF RUN IS LONGER THAN 6'.

NEVER USE PLASTIC DUCTING.

USE SMOOTH BORE METAL DUCTING.

MINIMIZE THE NUMBER OF FITTINGS (see chart).

WHEN YOU MUST USE FITTINGS, TRY TO SEPARATE THEM WITH SECTIONS OF
4' OR MORE OF STRAIGHT DUCT.

ALWAYS FOLLOW THE MANUFACTURER'S GUIDELINES FOR THE COOKING
EQUIPMENT YOU ARE VENTING.

IF MAKE UP AIR CONTROL DAMPERS ARE REQUIRED, POSITION THE SENSOR
IN A STRAIGHT RUN OF DUCT IDEALLY WITH 4' OF STRAIGHT DUCT BETWEEN
EACH SIDE OF THE SENSOR AND A DUCT FITTING. REMEMBER TO INCLUDE
POWER AND CONTROL WIRING FOR THIS IN YOUR PLANS.

ADHERE TO ALL LOCAL BUILDING CODES AND ORDINANCES.

USE THE WORKSHEET THAT FOLLOWS TO HELP CALCULATE THE
TOTAL EQUIVALENT FEET OF YOUR DUCT RUN.

TOTAL EQUIVALENT FEET SHOULD BE LESS THAN 100'.

ESTIMATING TOTAL EQUIVALENT FEET IN A DUCT

CAUSING AIR TO CHANGE DIRECTION CAUSES TURBULENCE AND RESTRICTS FLOW IN A SYSTEM. IF USING FLEXIBLE METAL DUCT - INCREASE ALL MULTIPLIERS BY 50% (12 BECOMES 18 - ETC.)

THIS EASY TO USE WORKSHEET IS FOR 1000 CFM OR LESS.











UNDER "QTY USED" ENTER HOW OF EACH SECTION YOU WILL BE USING.

IN THE FIRST TWO ROWS - ENTER HOW MANY FEET OF EACH TYPE OF STRAIGHT DUCT YOU WILL BE USING (I.E. FOR 20 FT ENTER 20, FOR 30' ENTER 30).

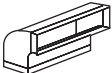
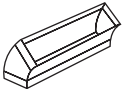
ENTER THE NUMBER OF EACH TYPE OF TURN YOU ARE USING AND THE TYPE OF END CAP.

MULTIPLY ACROSS EACH ROW THE "MULTIPLIER" x "QTY USED" TO GET THE EQUIVALENT FEET FOR THOSE COMPONENTS.

ADD UP ALL THE VALUES IN THE "EQUIVALENT FEET" COLUMN.

DUCT PIECE	DESCRIPTION	MULTIPLIER	QTY USED	EQUIVALENT FEET
	1' of 8" Round Duct	1		
	1' of 4" x 14" Rect. Duct	1		
	8" 90 Degree Elbow	12		
	8" 45 Degree Elbow	7		
	4" x 14" 90 Degree	14		
	4" x 14" 45 Degree	8		
	4" x 14" x 8" Round	2		
	4" x 14" x 8" Round 90 Degree	4		
	8" Round Wall Cap w Damper	24		
	4" x 14" 90 Wall cap w Damper	24		
	8" Round Roof Cap	33		
TOTAL EQUIVALENT FEET SHOULD BE LESS THAN 100				

TYPICAL INSTALLATION EXAMPLES

VENTED

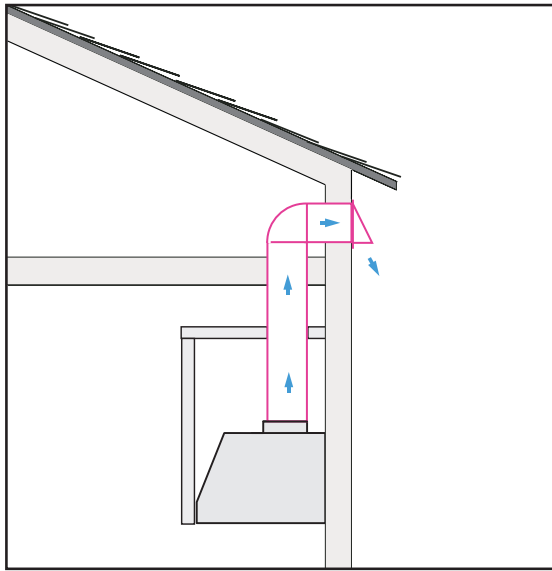

WALL EXHAUST

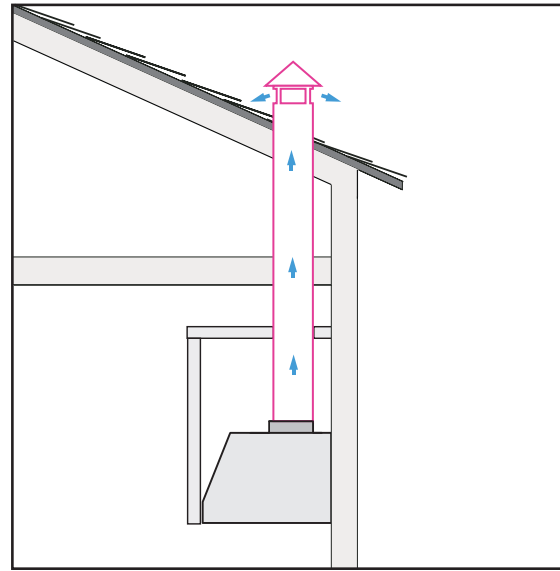

ROOF EXHAUST

RECIRCULATION

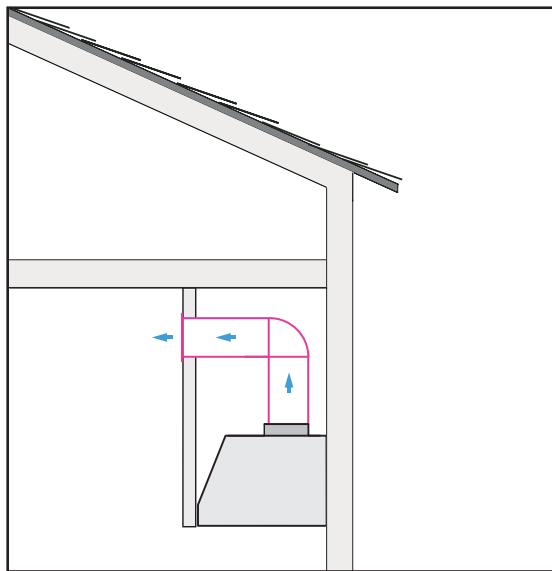

SOFFIT EXHAUST

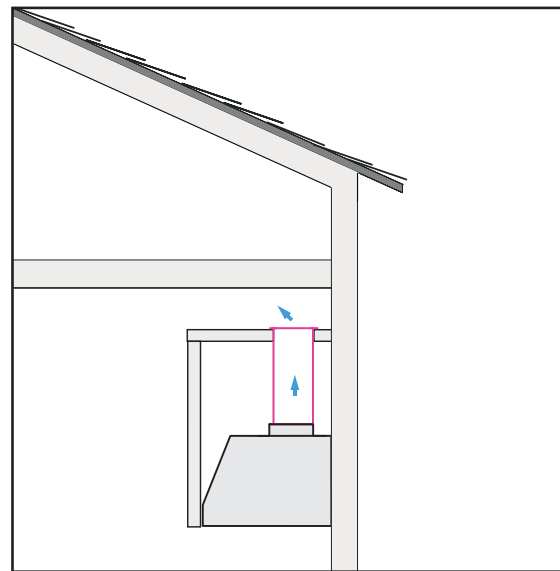

CABINET TOP EXHAUST

RECIRCULATION EXHAUST MUST BE RETURNED TO THE SPACE

DIMENSIONS

› Front of hood

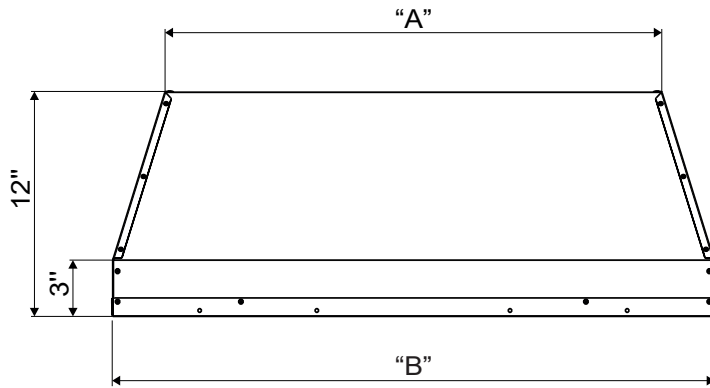

› Side of hood

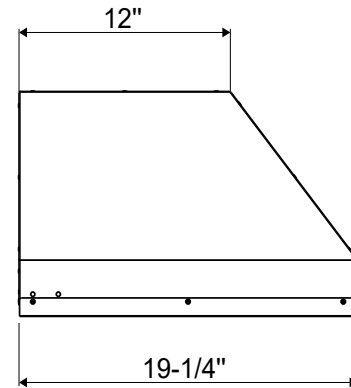

MODEL	DIM "A"	DIM "B"
XOIL48KS	40-3/8"	46-3/8"

› Top of hood

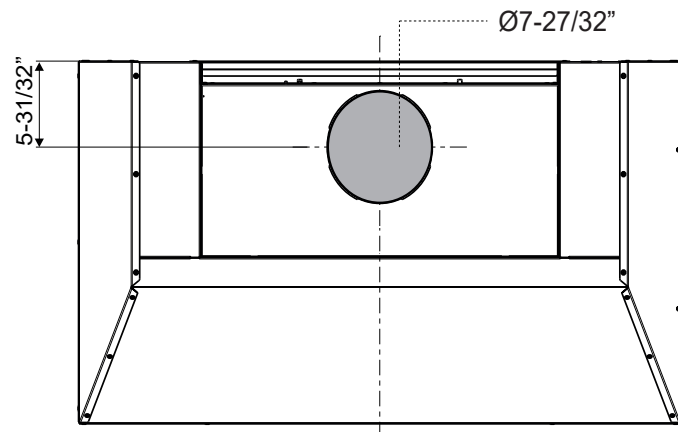

HIGHS AND LOWS



All range hoods have a recommended range of installation height over the cooking surface.

It is important to install the hood at the proper mounting height. Hoods mounted too low could result in heat damage and fire hazard; while hoods mounted too high will be hard to reach and will lose its performance and efficiency.

SWITCHING TOP AND REAR VENTING

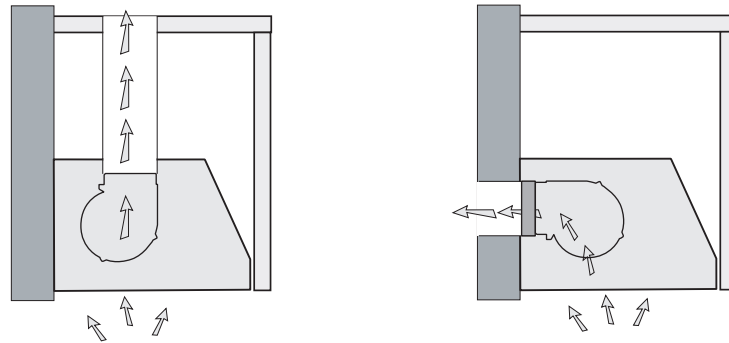

TO CONVERT THE UNIT FROM TOP EXHAUST TO REAR EXHAUST FOLLOW THESE SIMPLE STEPS:

1. Unplug the quick disconnect coupling that supplies power to the motor.

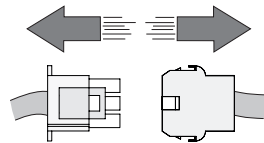

2. Remove the eighteen (18) screws that fasten the blower assembly and filler plate to the hood.

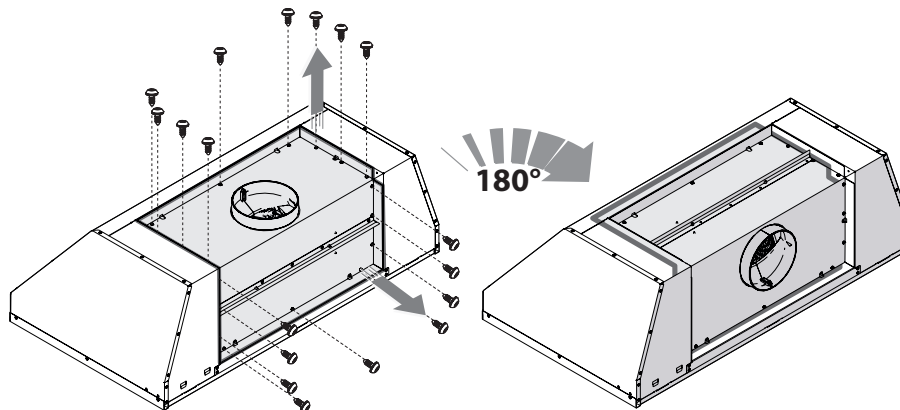

3. Remove the blower assembly and filler plate, invert 180° as shown and fasten in place using the eighteen (18) screws previously removed.

4. Reconnect the quick disconnect plug.

THE CUT OUT

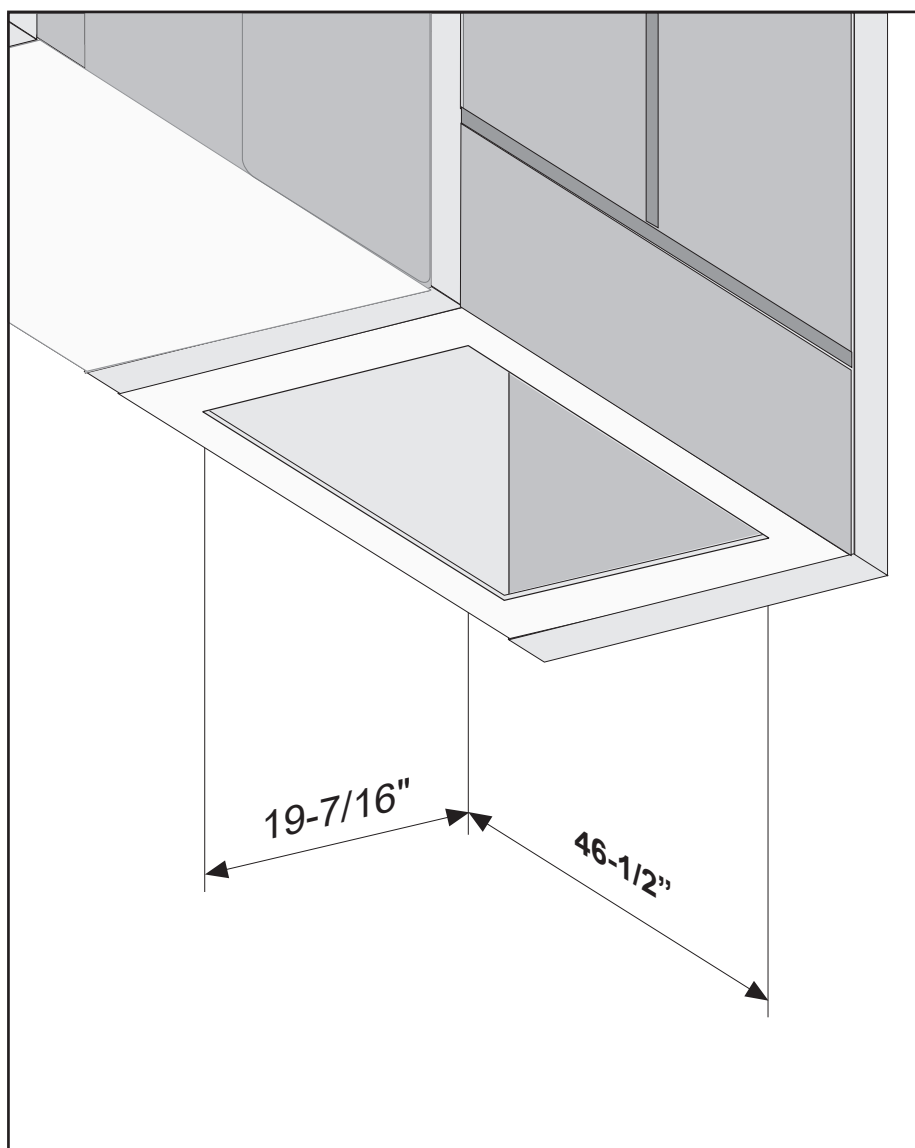

To install the hood into a custom canopy or cabinet, refer to the cutout dimensions above for your particular model.

INSTALLATION

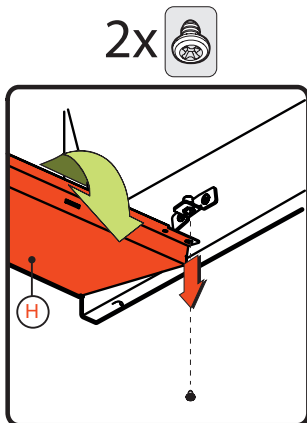
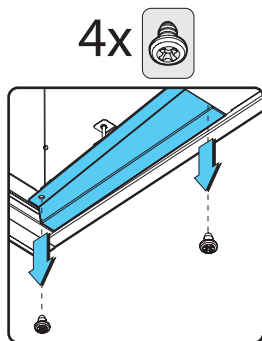
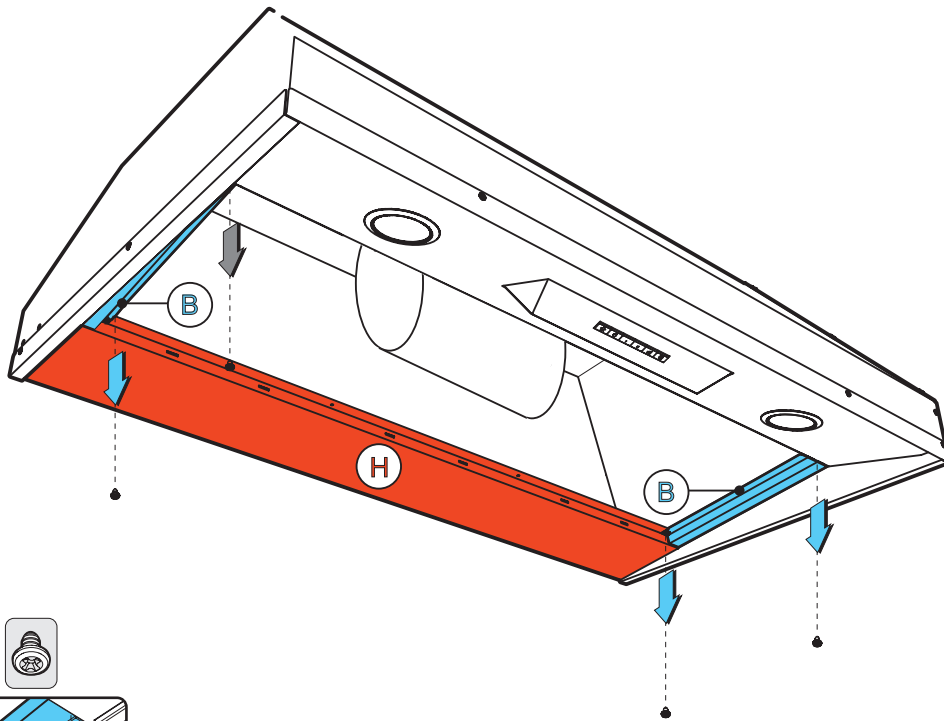

BEFORE FITTING THE HOOD INTO THE CABINET:

1. Remove the four (4) screws holding the side bracket (B) in place. Remove the brackets and set aside.
2. Remove the two (2) screws holding the bracket (H) in place and tilt down.

INSTALLATION CONTINUED

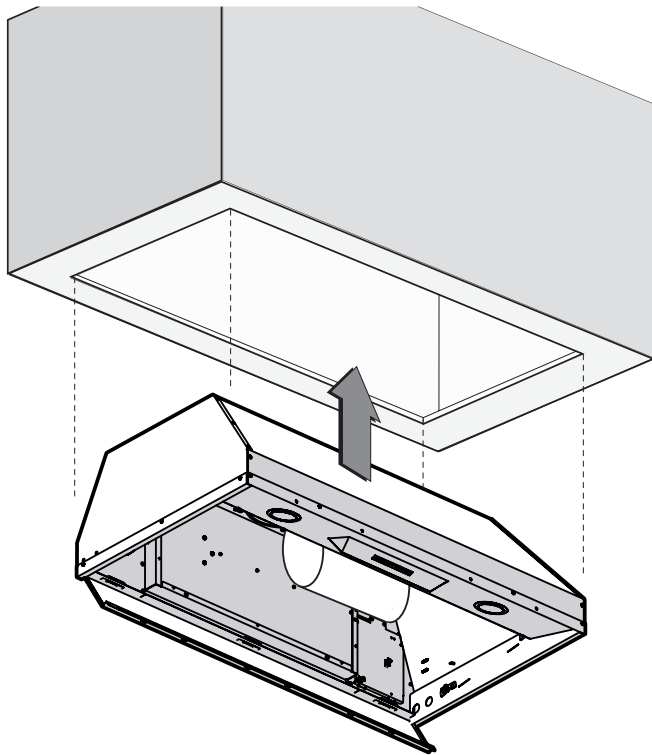

INSERT THE HOOD INTO THE CUTOUT

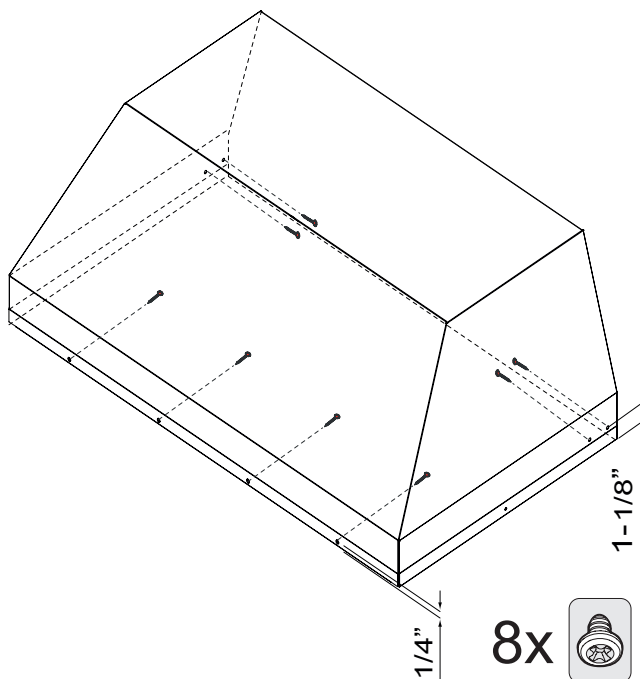

FASTEN THE HOOD IN PLACE

Using four (4) screws along the inside front edge and four (4) screws in the back corners as shown

ELECTRICAL CONNECTION

1. Route the power cord to the junction box inside the hood.
2. Using listed conduit fittings and connectors, connect the power supply to the box and each line to the appropriate wire following this color convention:

BLACK = HOT LEG

WHITE = NEUTRAL

GREEN/YELLOW = GROUND

Polarity must be observed.

Unit must be properly grounded.

Use a double throw disconnect switch.

3. Replace the box cover
4. Replace the Anti-grease Baffles.

All wiring must be in compliance with national electrical code, ANSI/NFPA 70-1999 and all local codes and regulations.

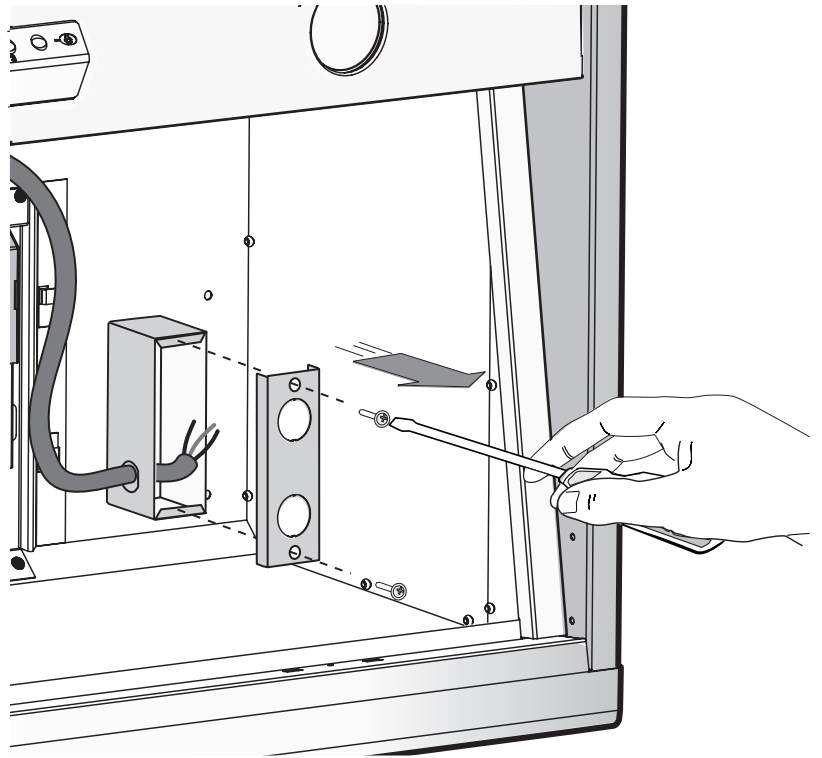

MAINTENANCE

Regular cleaning and maintenance is the key to long life and peak performance of any equipment.

ANTI-GREASE BAFFLE FILTERS: Your XO hood is equipped with stainless steel pro-style baffle filters designed to capture grease from cooking. The baffles are easily removed for cleaning either by soaking in a warm, mild dish detergent solution, rinsing thoroughly and drying - or - by washing in your dishwasher.

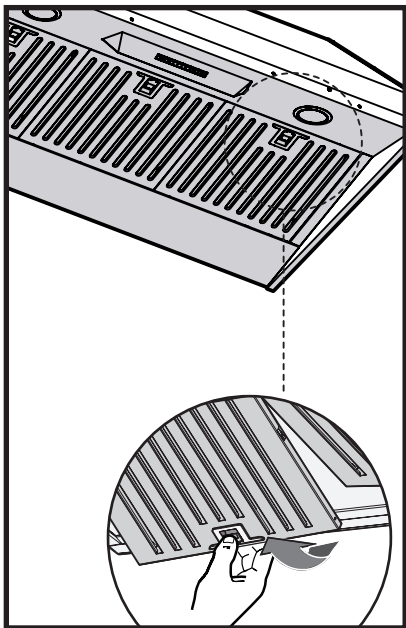

TO REMOVE THE BAFFLES:

1. Pull down on the release latch (shown left)
2. Lower the front edge of the baffle
3. Pull forward and remove
4. To replace, insert the rear of the baffle, holding the latch open, swing the the front up into place and release the latch.

The importance of this simple process is essential for two reasons. First to help keep your kitchen clean and healthy, but it is also critical to minimize the risk of fire.

Baffle filters should be cleaned at least once every 2 months, more frequently depending on the type of cooking performed and the build up of grease.

CLEANING STAINLESS STEEL:

Do not use corrosive detergents, abrasive detergents or oven cleaners.

Do not use any product containing chlorine bleach or any product containing chloride.

Do not use steel wool or abrasive scrubbing pads which will scratch and damage surface.

Cleaning Stainless Steel Clean periodically with warm soapy water and clean cotton cloth or micro fiber cloth. Always rub in the direction of the stainless steel grain. To remove heavier grease build up use a liquid degreaser detergent. After cleaning use a non-abrasive stainless steel polish/cleaners, to polish and buff out the stainless luster and grain. Always rub lightly, with a clean cotton cloth or a micro fiber cloth and buff in the direction of the stainless steel grain.

Any painted surfaces should be cleaned with warm water and detergent only.

MAINTENANCE CONTINUED



LED LIGHT REPLACEMENT

The LED light modules are held in place by spring clips and pull down directly from the housing.

Unplug the plastic molex connector.

Plug in the new fixture and snap back into place.

EASY TO OPERATE



Your XO range hood is controlled by these electronic push buttons which illuminate when activated.

BUTTON ☀️ : Controls the LED lights. There are three illumination levels. Press the button Once for HIGH; Twice for MEDIUM; Three times for LOW; Four times for OFF.

BUTTON 0: Turns both the Blower and Lights On and Off

BUTTON 1: Blower motor operates on **LOW** speed.

BUTTON 2: Blower motor operates on **MEDIUM** speed.

BUTTON 3: Blower motor operates on **HIGH** speed.

POWER BOOST

Press and Hold BUTTON 3 for 2 seconds.

This will increase airflow to a fourth and even higher speed for 10 minutes.

When activated the button will blink to alert you it is running.

After 10 minutes the blower speed will return to its last setting.

To manually stop the **POWER BOOST** before 10 minutes has elapsed:

Press **BUTTON 3** and it will revert to HIGH speed, or

Press **BUTTON 0** to shut the blower off completely

NOTE: The POWER BOOST function will operate even when the hood is off.

BUTTON T: Activates and Deactivates the **TIMER** Function

Pressing **BUTTON T** (whether the blower is off or running) will cause the motor to run at **LOW** speed for 5 minutes before shutting off the blower and lights automatically.

While the **TIMER** is activated, you can change speed or engage **POWER BOOST**, the hood will still shut off after 5 minutes.

To manually turn the the unit off before 5 minutes has elapsed:

Press **BUTTON T** or **BUTTON 0**.

OPTIONAL REMOTE CONTROL (purchased separately)

The remote control must be synchronized prior to use.

To synchronize the remote control with the hood follow these simple steps:

1. Standing near the hood, while it is not running, press and hold **BUTTON** on the hood for 4 seconds -the button should start to blink for 5 seconds.
2. When the button on the hood starts to blink, Press any button on the remote. The hood and remote are now synchronized.
3. If the synchronization fails for any reason, repeat steps 1 &2



XOVREMOTE1

ACCESS PARTS & ACCESSORIES

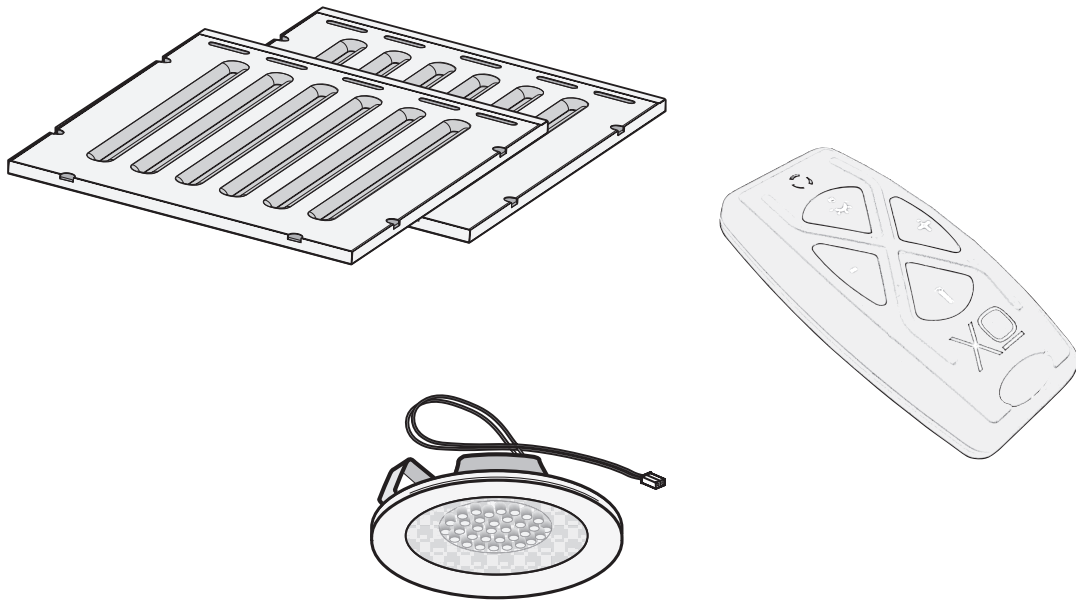

FILTERS

REPLACEMENT LIGHTS

REMOTE CONTROLS

REPLACEMENT SWITCHES

BLOWER MOTORS

FAN WHEELS

**ALL OF THESE PARTS AND MORE ARE AVAILABLE, SIMPLY VISIT
WWW.XOAPPLIANCE.COM and click on PARTS STORE
OR CALL US AT 973-403-8900**

NOTES

WE'VE GOT YOUR BACK

90 DAY LOVE IT or LEAVE IT. For 90 Days all our products are backed by our unique Love it or Leave it Guarantee.

TWO-YEAR PARTS & LABOR LIMITED WARRANTY. XO warrants to the original purchaser of every new XO ventilation unit, the cabinet and all parts thereof, to be free from defects in material or workmanship under normal and proper use and maintenance as specified by XO and upon proper installation and start-up in accordance with the instruction packet supplied with each XO unit. XO's obligation under this warranty is limited to a period of two (2) years from the date of original purchase.

WARRANTY CLAIMS. All claims for labor or parts must be made directly through XO. All claims should include: model number and serial number of cabinet, proof of purchase, and date of installation. In case of warranted compressor, the compressor model tag must be returned to XO along with the above listed information.

WHAT IS NOT COVERED BY THIS WARRANTY. XO's sole obligation under this warranty is limited to either repair or replacement of parts, subject to the additional limitations below. This warranty neither assumes nor authorizes any person to assume obligations other than those expressly covered by this warranty. Open box, factory seconds, scratch and dent, floor models and commercial applications are excluded from these warranties.

WARRANTY IS NOT TRANSFERABLE. This warranty is not assignable and applies only in favor of the original purchaser/user at the original installation location. Any such assignment or transfer shall void the warranties herein made and shall void all warranties, express or implied, including any warranty or merchantability or fitness for a particular purpose.

IMPROPER USAGE. XO assumes no liability for parts or labor coverage for component failure or other damages resulting from improper usage or installation or failure to clean and/or maintain product as set forth in the warranty packet provided with the unit.

ALTERATION OR NEGLECT. XO is not responsible for the repair or replacement of any parts that XO determines have been subjected after the date of manufacture to alteration, neglect, abuse, misuse, accident, damage during transit or installation, fire, flood, or act of God.

IMPROPER ELECTRICAL CONNECTIONS. XO is not responsible for the repair or replacement of failed or damaged components resulting from electrical power failure, high or low voltage, use of extension cords, or improper grounding of the unit.

YOUR RIGHTS UNDER STATE LAW. This warranty gives you specific legal rights and you may have other rights that vary from state to state. Some states do not allow the exclusion or limitation of consequential damages or a limitation on how long an implied warranty lasts, so the above exclusion or limitation may not apply to you.

OUTSIDE U.S. This warranty does not apply to, and XO is not responsible for, any warranty claims made on products sold or used outside the 48 continental United States.

To obtain service:

Call 973-403-8900 | email service@xoappliance.com | or submit a request on our website
www.xoappliance.com



XOIL30MANUAL2020

