

# XO

## KITCHEN VENTILATION SYSTEMS



Insert

### XOI22SMUA

The center panel of the XOI22SMUA provides more than a sleek European appearance, it diverts exhaust flow for perimeter aspiration to improve capture. While the powerful tangential blower and integral sound reduction design minimize background noise.



Wireless  
Remote  
Included

ADA  
Compliant

# XO

[www.xoappliance.com](http://www.xoappliance.com)

# XO Spec Sheet

Insert

**2** YEAR  
PARTS & LABOR  
WARRANTY



**Model:** XO122SMUA

**Sizes:** 22"

**Depth:** 11 9/16"

## Features and Benefits:

- 395 CFM tangential blower optimally removes Smoke, Grease and Odors.
- 3 speed electronic push button remote control
- 15 Minute auto shut-off timer function
- Twin, Three level 50W Halogen lighting provides the perfect amount of illumination
- Dim: 20 11/16" W x 11 9/16" D x 11 1/4" T  
Cut Out: 19 1/8" W x 10 3/8" D
- The center panel masks dishwasher safe filters and directs air flow for perimeter aspiration, superior capture with a sleek European look.
- Mounting Height from cooking surface 27"-32"
- Sound level 0.5 - 3.2 Sones

## Duct Options and Electrical Requirements:

- 6 inch duct required.
- Ductless Option for applications where no ducting is available
- AC 120v-60Hz (6.2amp).

## Options:

Optional recirculation kit available  
XORFK04

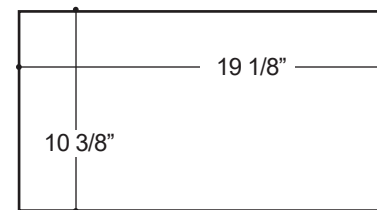
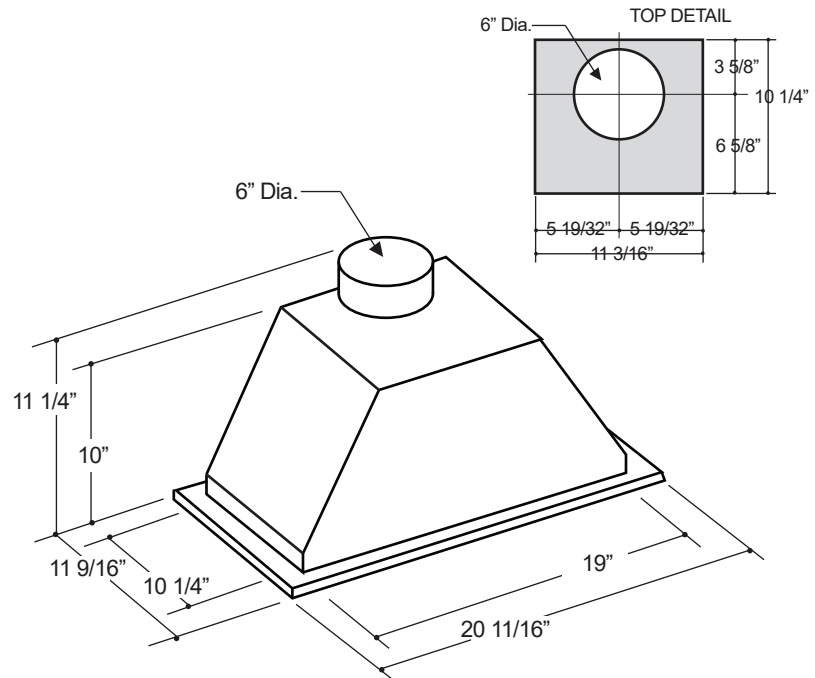

CUT OUT DIMENSION

WIDTH	DEPTH	CFM
22"	11 5/8"	395

# XO

www.xoappliance.com

XO is Exclusively Distributed by:  
Eastern Marketing Corp 24 Eisenhower Parkway Roseland,  
New Jersey 07068 800-966-8300  
www.easternmarketingcorp.com

All XO hoods are UL approved. 

DESIGNED & CRAFTED IN  
**ITALY**