

XO

SINK PRO NANOGRIND

MODEL XOD1HPBF

BATCH FEED WASTE DISPOSAL

Comes with all these
Features Included:

- Permanent Magnet 2850 RPM Motor
- Generates High Torque / Avoids Jams
- Stainless Steel Turntable & Cast Impellers
- Bio-guard Antimicrobial Protection
- Removable Splash Guard
- Factory Installed Molded Power Cord & Plug
- Precision Balanced
- Sound Insulation Shield
- XO QuickConnect Mount

SEPTIC SAFE

Designed to handle
Common Kitchen
Food Waste Like:

Melon Rinds
Small Bones
Corn Cobs
Nut Shells
Fruit Pits
Tea Leaves
Coffee Grounds
Fish Bones
Egg Shells
Grapefruit Halves
Vegetable Scraps



**LIFE
TIME**
IN HOME
WARRANTY

XO LOVE IT
OR LEAVE IT
100% GUARANTEED

For 90 Days, all our products
are backed by our unique
Love It or Leave It Guarantee

XO

the next level
in luxury appliances



XO SINK PRO NANOGRIND

MODEL XOD1HPBF

BATCH FEED 1 HP
FOOD WASTE DISPOSAL

The XO QuicKconnect System

ATTACH SINK FLANGE
ASSEMBLY TO SINK



INSTALL THE
DRAIN ELBOW
IN THE DISPOSER



TWIST & LOCK
DISPOSER TO SINK
FLANGE ASSEMBLY



MAKE PLUMBING
CONNECTIONS &
PLUG IN POWER CORD

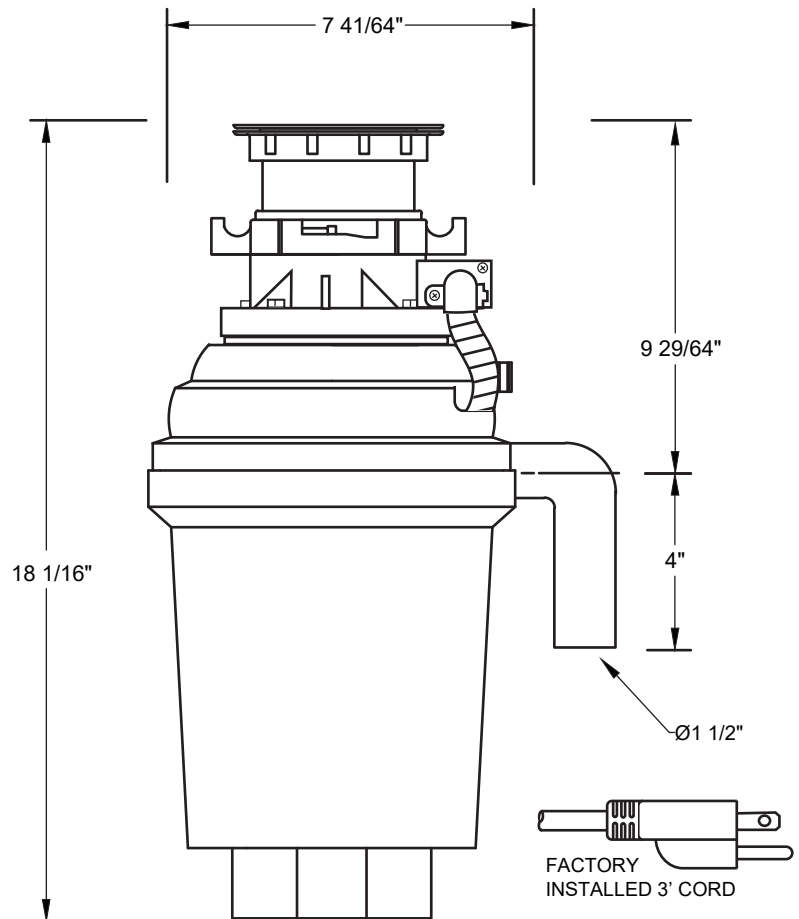

SAFETY FEED GUARD

No remote switch
required.
Unit operates when
the Safety Feed Guard
is inserted into the
drain and pushed down
to activate



SPECIFICATIONS

HP	1
Motor Type	Permanent Magnet
Feed	Continuous
Volts	120V
Amps	6.3 amps
Frequency	50/60Hz
Motor Speed	2850RPM
Hopper Capacity	29oz
Balance Level	G0.4
Sink Flange	Stainless Steel
Stopper	Stainless Steel
Drain Elbow	ABS
Bearings	Permanently Lubricated, Sleeve Type
Manual Reset Protector	Protection for Overload and Temp.
Shipping Weight	13 lbs
Pallet Quantity	64pcs

XO Appliance - 24 Eisenhower Parkway - Roseland, NJ 07068
(800)966-8300 www.XOAppliance.com