

# XO SINK PRO NANOGRIND

## MODEL XOD12HPBF BATCH FEED WASTE DISPOSAL

Comes with all these  
Features Included:

- Permanent Magnet 2850 RPM Motor
- Generates High Torque / Avoids Jams
- Stainless Steel Turntable & Cast Impellers
- Bio-guard Antimicrobial Protection
- Removable Splash Guard
- Factory Installed Molded Power Cord & Plug
- Precision Balanced
- Sound Insulation Shield
- XO QuicKconnect Mount

### SEPTIC SAFE

Designed to handle  
Common Kitchen  
Food Waste Like:

Melon Rinds  
Small Bones  
Corn Cobs  
Nut Shells  
Fruit Pits  
Tea Leaves  
Coffee Grounds  
Fish Bones  
Egg Shells  
Grapefruit Halves  
Vegetable Scraps



COMPACT DESIGN  
PERFECT FOR APARTMENTS  
& MULTIFAMILY



1/2 HP

5 YEAR  
IN HOME  
WARRANTY

XO

LOVE IT  
OR LEAVE IT

100% GUARANTEED

For 90 Days, all our products  
are backed by our unique  
Love It or Leave It Guarantee

# XO

the next level  
in luxury appliances

# XO SINK PRO NANOGRIND

MODEL XOD12HPBF

BATCH FEED 1/2 HP  
FOOD WASTE DISPOSAL

## The XO QuicKconnect System

ATTACH SINK FLANGE  
ASSEMBLY TO SINK



INSTALL THE  
DRAIN ELBOW  
IN THE DISPOSER



TWIST & LOCK  
DISPOSER TO SINK  
FLANGE ASSEMBLY



MAKE PLUMBING  
CONNECTIONS &  
PLUG IN POWER CORD

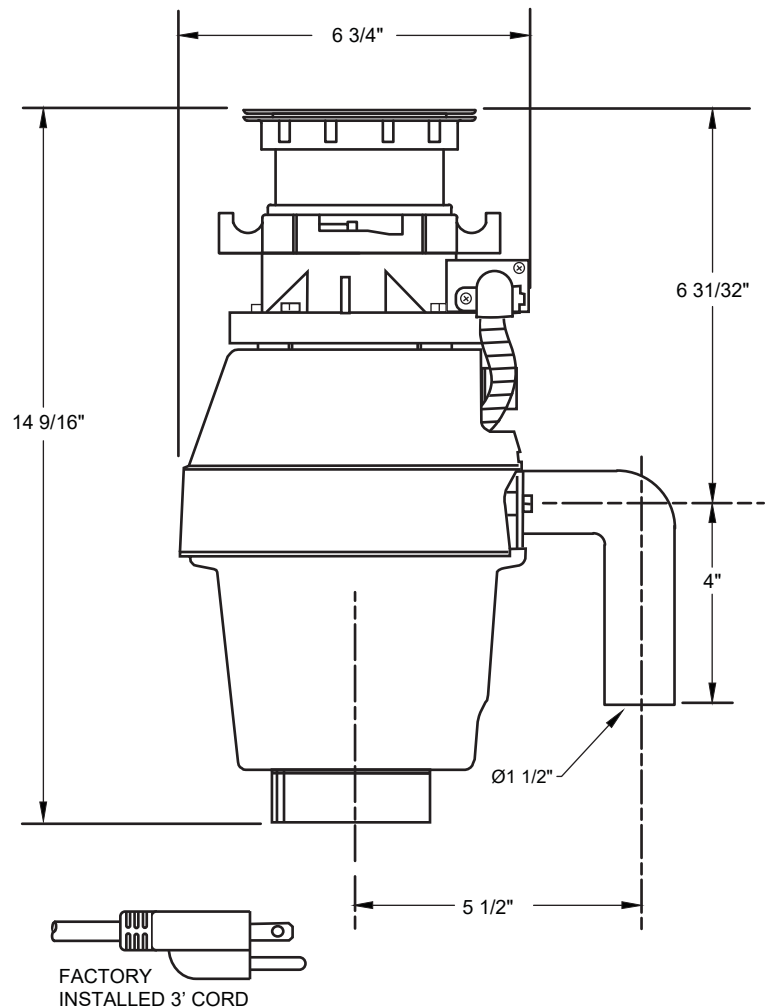

## SAFETY FEED GUARD

No remote switch  
required.  
Unit operates when  
the Safety Feed Guard  
is inserted into the  
drain and pushed down  
to activate



## SPECIFICATIONS

HP	1/2
Motor Type	Permanent Magnet
Feed	Continuous
Volts	120V
Amps	3.1 amps
Frequency	50/60Hz
Motor Speed	2850 RPM
Hopper Capacity	29oz
Balance Level	G0.4
Sink Flange	Stainless Steel
Stopper	Stainless Steel
Drain Elbow	ABS
Bearings	Permanently Lubricated, Sleeve Type
Manual Reset Protector	Protection for Overload and Temp.
Shipping Weight	10.6 lbs
Pallet Quantity	64pcs

XO Appliance - 24 Eisenhower Parkway - Roseland, NJ 07068  
(800)966-8300 [www.XOAppliance.com](http://www.XOAppliance.com)