



SLATE™

GP30 / GPD30 / GPD30B / GPB30 / GPD36

30"/36" Rust-Resistant Griddle

LP OWNER'S MANUAL



REGISTER TODAY

Register your gas grill and receive special content to make you the ultimate backyard hero. Scan the QR Code or register online at weber.registria.com

Important Safety Information

DANGER, WARNING, and CAUTION statements are used throughout this Owner's Manual to emphasize critical and important information. Read and follow these statements to help ensure safety and prevent property damage. The statements are defined below.

⚠ DANGER: Indicates a hazardous situation which, if not avoided, *will result in death or serious injury.*

⚠ WARNING: Indicates a hazardous situation which, if not avoided, *could result in death or serious injury.*

⚠ CAUTION: Indicates a hazardous situation which, if not avoided, *could result in minor or moderate injury.*

USE OUTDOORS ONLY.

READ THE INSTRUCTIONS BEFORE USING THE APPLIANCE (GRILL).

NOTICE TO INSTALLER: These instructions must be left with the consumer.

NOTICE TO CONSUMER: Retain these instructions for future reference.

⚠ DANGER

If you smell gas:

- Shut off gas to the appliance (grill).
- Extinguish any open flame.
- Open lid.
- If odor continues, keep away from the appliance (grill) and immediately call your gas supplier or your fire department.

⚠ WARNING

- Do not store or use gasoline or other flammable liquids or vapors in the vicinity of this (grill) or any other appliance.
- An LP cylinder (tank) not connected for use shall not be stored in the vicinity of this (grill) or any other appliance.

Installation and Assembly

- ⚠ **DANGER:** This grill is not intended to be installed in or on recreational vehicles or boats.
- ⚠ **WARNING:** Do not use this grill unless all parts are in place and the grill was properly assembled according to the assembly instructions.
- ⚠ **WARNING:** Do not build this model of grill in any built-in or slide-in construction.
- ⚠ **WARNING:** Do not modify the appliance (grill). Liquid propane gas is not natural gas. The conversion or attempted use of natural gas in a liquid propane gas unit or liquid propane gas in a natural gas unit is unsafe and will void your warranty.
- In the United States, installation must conform with local codes or, in the absence of local codes, with either the National Fuel Gas Code, ANSI Z223.1/NFPA 54, Natural Gas and Propane Installation Code, CSA B149.1; or Propane Storage and Handling Code, B149.2; or the Standard for Recreational Vehicles, ANSI A119.2/NFPA 1192, and CSA Z240 RV Series, Recreational Vehicle Code, as applicable.
- In Canada, the installation of this grill must comply with local codes and/or the latest edition of Standard CAN/CSA-B149.2 (Propane Storage and Handling Code). These instructions, while generally acceptable, do not necessarily comply with the Canadian installation codes, particularly with piping above and below ground.
- In Mexico, if there are local codes that apply to portable gas appliances, you must comply with the latest edition of Official Mexican Standard (NOM).
- If an external electrical source is utilized (such as a rotisserie) it must be electrically grounded in accordance with local codes or, in the absence of local codes, with the National Electrical Code, ANSI/NFPA 70, or the Canadian Electrical Code, Part 1, CSA C22.1.

Operation

- ⚠ **DANGER:** Only use the grill outdoors in a well-ventilated area. Do not use in a garage, building, breezeway, tent, any other enclosed area, or beneath overhead combustible construction.
- An appliance is considered to be outdoors if installed with shelter no more inclusive than with walls on three sides, but with no overhead cover; all openings must be permanently open; sliding doors, garage doors, windows, or screened openings are not considered as permanent openings.
- An appliance is considered to be outdoors if installed with shelter no more inclusive than within a partial enclosure that includes an overhead cover and no more than two sidewalls. The sidewalls may be parallel, as in a breezeway, or at right angles to each other; all openings must be permanently open; sliding door, garage doors, windows, or screened openings are not considered as permanent openings.
- An appliance is considered to be outdoors if installed with shelter no more inclusive than within a partial enclosure that included an overhead cover and three sidewalls, as long as 30% or more of the horizontal periphery of the enclosure is permanently open. All openings must be permanently open; sliding doors, garage doors, windows, or screened openings are not considered as permanent openings.
- The minimum ambient operating temperature for safe use of the appliance shall be 0° F (-17° C).
- ⚠ **DANGER:** Do not use the grill in any vehicle or in any storage or cargo area of any vehicle. This includes, but is not limited to, cars, trucks, station wagons, mini-vans, sport utility vehicles, recreational vehicles, and boats.
- ⚠ **DANGER:** Do not use the grill within 24 inches (61 cm) of combustible materials.
- ⚠ **DANGER:** Keep the cooking area clear of flammable vapors and liquids such as gasoline, alcohol, etc., and combustible materials.
- ⚠ **DANGER:** The grill is not intended for and should never be used as a heater.
- ⚠ **DANGER:** This appliance (grill) must be kept away from flammable materials during use.

Keep this Owner's Manual for future reference, thoroughly read through it, and if you have any questions please contact us today.



FEATURES OF THIS GRILL

To access complete user information, scan the QR Code and enter your serial number, or browse online at

weber.com/literature-online.

Serial Number

Write your grill's serial number in the box above for future reference. The serial number is on the grill's data label.

8652619_072924_WEB_US



WARRANTY

- ⚠ **DANGER:** Do not put a grill cover or anything flammable on, or in the storage area under the grill while it is in operation or is hot.
- ⚠ **DANGER:** Should a grease fire occur, turn off all burners and leave lid closed until fire is out.
- ⚠ **WARNING:** Accessible parts may be very hot. Keep young children away.
- ⚠ **WARNING:** The use of alcohol, prescription drugs, non-prescription drugs, or illegal drugs may impair the consumer's ability to properly and safely assemble, move, store, or operate the grill.
- ⚠ **WARNING:** Never leave the grill unattended during pre-heating or use. Exercise caution when using this grill. The entire cookbox gets hot when in use.
- ⚠ **WARNING:** Do not move the appliance (grill) during use.
- ⚠ **WARNING:** Keep any electrical supply cord and the fuel supply hose away from any heated surfaces.
- ⚠ **CAUTION:** This product has been safety-tested and is only certified for use in a specific country. Refer to country designation located on outside of box.
- ⚠ **CAUTION:** The grill is not intended for commercial use.
- ⚠ **CAUTION:** Do not use charcoal or lava rock in the grill.

Storage and/or Non-Use

- ⚠ **WARNING:** Turn off the gas supply at the gas cylinder (tank) after use.
- ⚠ **WARNING:** LP tanks must be stored outdoors out of the reach of children and must not be stored in a building, garage, or any other enclosed space.
- ⚠ **WARNING:** After a period of storage and/or nonuse, the grill should be checked for gas leaks and burner obstructions before use.
- ⚠ **Storage of the grill indoors is permissible only if the LP tank is disconnected and removed from the grill.**

California Proposition 65

- ⚠ **WARNING:** Combustion byproducts produced when using this product contain chemicals known to the state of California to cause cancer, birth defects, or other reproductive harm.
- ⚠ **PROPOSITION 65 WARNING:** Handling the brass material on this product exposes you to lead, a chemical known to the state of California to cause cancer, birth defects, or other reproductive harm. *Wash hands after handling this product.*

Limited Warranty

Thank you for purchasing a WEBER product. Weber-Stephen Products LLC, 1415 S. Roselle Road, Palatine, Illinois 60067 ("WEBER") prides itself on delivering a safe, durable, and reliable product.

This is WEBER's Limited Warranty ("Warranty") provided to you at no extra charge. It contains the information you will need to have your WEBER product repaired in the unlikely event of a failure or defect.

Pursuant to applicable laws, the customer has several rights in case the product is defective. Those rights include supplementary performance or replacement, abatement of the purchasing price, and compensation. These and other statutory rights remain unaffected by this warranty provision. In fact, this warranty grants additional rights to the Owner that are independent from statutory warranty provisions.

WEBER'S LIMITED WARRANTY

WEBER warrants, to the purchaser of the WEBER product (or in the case of a gift or promotional situation, the person for whom it was purchased as a gift or promotional item) ("Owner"), that the WEBER product is free from defects in material and workmanship for the period(s) of time specified below when assembled and operated in accordance with the accompanying Owner's Manual, normal wear and tear excluded. (Note: If you lose or misplace your WEBER Owner's Manual, a replacement is available online at www.weber.com.) WEBER agrees within the framework of this warranty to repair or replace the part that is defective in material or workmanship subject to the limitations, and exclusions listed below. TO THE EXTENT ALLOWABLE BY APPLICABLE LAW, THIS WARRANTY IS EXTENDED ONLY TO THE ORIGINAL PURCHASER AND IS NOT TRANSFERABLE TO SUBSEQUENT OWNERS, EXCEPT IN THE CASE OF GIFTS AND PROMOTIONAL ITEMS AS NOTED ABOVE.

WEBER stands by its products and is happy to provide you with the Warranty described for material defects in the grill or its relevant components, normal wear and tear excepted.

- "Normal wear and tear" includes cosmetic and other immaterial deterioration that may come with ownership of your grill over time, such as surface rust, dents / scratches, etc.

However, WEBER will honor this Warranty for the grill or its relevant components where damage or dysfunction results from a material defect.

- "Material defect" includes rust through or burn through of certain parts, or other damage or failure inhibiting your ability to safely / properly use your grill.

OWNER'S RESPONSIBILITIES UNDER THIS WARRANTY

To ensure trouble-free warranty coverage, it is important (but it is not required) that you register your WEBER product online at www.weber.com. Please also retain your original sales receipt and/or invoice. Registering your WEBER product confirms your warranty coverage and provides a direct link between you and WEBER in case we need to contact you. If you have not had time to register your grill before calling for Warranty service, please have the following information available when you do call:

Name – Address – Phone Number – Email – Serial Number – Purchase Date – Purchase Dealer – Model – Color – Primary Issue

The above warranty only applies if the Owner takes reasonable care of the WEBER product by following all assembly instructions, usage instructions, and preventative maintenance as outlined in the accompanying Owner's Manual, unless the Owner can prove that the defect or failure is independent of non-compliance with the above mentioned obligations. If you live in a coastal area, or have your product located near a pool, maintenance includes regular washing and rinsing of the exterior surfaces as outlined in the accompanying Owner's Manual.

WARRANTY HANDLING / EXCLUSION OF WARRANTY

If you believe that you have a part which is covered by this Warranty, please contact WEBER Customer Service using the contact information on our website (www.weber.com), or such country-specific website to which Owner may be redirected). WEBER will, upon investigation, repair or replace (at its option) a defective part that is covered by this Warranty. In the event that repair or replacement are not possible, WEBER may choose (at its option) to replace the grill in question with a new grill of equal or greater value. WEBER may ask you to return parts for inspection, shipping charges to be pre-paid by owner.

When you contact Customer Service, please have the following information available:

Name – Address – Phone Number – Email – Serial Number – Purchase Date – Purchase Dealer – Model – Color – Primary Issue

This WARRANTY lapses if there are damages, deteriorations, discolorations, and/or rust for which WEBER is not responsible caused by:

- Abuse, misuse, alteration, modification, misapplication, vandalism, neglect, improper assembly or installation, and failure to properly perform normal and routine maintenance;
- Insects (such as spiders) and rodents (such as squirrels), including but not limited to damage to burner tubes and/or gas hoses;
- Exposure to salt air and/or chlorine sources such as swimming pools and hot tubs/spas;
- Severe weather conditions such as hail, hurricanes, earthquakes, tsunamis or surges, tornadoes or severe storms.
- Acid rain and other environmental factors.

Using third party parts will not void this Warranty. However, any parts that are used and/or installed on your WEBER product that are not genuine WEBER parts are not covered by this Warranty. In addition, any damages that result from the use and/or installation of parts on your WEBER product that are not genuine WEBER parts are not covered by this Warranty. Any conversion of a gas grill not authorized by WEBER and performed by a WEBER authorized service technician will void this Warranty.

PRODUCT WARRANTY PERIODS

Cookbox:

5 years, no rust through/burn through
(2 years paint excluding fading or discoloration)

Hard cover assembly:

5 years, no rust through/burn through
(2 years paint excluding fading or discoloration)

Stainless steel burner tubes:

5 years, no rust through/burn through

Griddle

5 years (excluding rust)

All remaining parts:

2 years (excluding normal wear and tear)

DISCLAIMERS

APART FROM THE WARRANTY AND DISCLAIMERS AS DESCRIBED IN THIS WARRANTY STATEMENT, THERE ARE EXPLICITLY NO FURTHER WARRANTY OR VOLUNTARY DECLARATIONS OF LIABILITY GIVEN HERE WHICH GO BEYOND THE STATUTORY LIABILITY APPLYING TO WEBER. THE PRESENT WARRANTY STATEMENT ALSO DOES NOT LIMIT OR EXCLUDE SITUATIONS OR CLAIMS WHERE WEBER HAS MANDATORY LIABILITY AS PRESCRIBED BY STATUTE.

NO WARRANTIES SHALL APPLY AFTER THE APPLICABLE PERIODS OF THIS WARRANTY. NO OTHER WARRANTIES GIVEN BY ANY PERSON, INCLUDING A DEALER OR RETAILER, WITH RESPECT TO ANY PRODUCT (SUCH AS ANY "EXTENDED WARRANTIES"), SHALL BIND WEBER. THE EXCLUSIVE REMEDY OF THIS WARRANTY IS REPAIR OR REPLACEMENT OF THE PART OR PRODUCT. IN NO EVENT UNDER THIS WARRANTY SHALL RECOVERY OF ANY KIND BE GREATER THAN THE AMOUNT OF THE PURCHASE PRICE OF THE WEBER PRODUCT SOLD.

YOU ASSUME THE RISK AND LIABILITY FOR LOSS, DAMAGE, OR INJURY TO YOU AND YOUR PROPERTY AND/OR TO OTHERS AND THEIR PROPERTY ARISING OUT OF THE MISUSE OR ABUSE OF THE PRODUCT OR FAILURE TO FOLLOW INSTRUCTIONS PROVIDED BY WEBER IN THE ACCOMPANYING OWNER'S MANUAL.

PARTS AND ACCESSORIES REPLACED UNDER THIS WARRANTY ARE WARRANTED ONLY FOR THE BALANCE OF THE ABOVE MENTIONED ORIGINAL WARRANTY PERIOD(S).

THIS WARRANTY APPLIES TO PRIVATE SINGLE FAMILY HOME OR APARTMENT USE ONLY AND DOES NOT APPLY TO WEBER GRILLS USED IN COMMERCIAL, COMMUNAL OR MULTI-UNIT SETTINGS SUCH AS RESTAURANTS, HOTELS, RESORTS, OR RENTAL PROPERTIES.

WEBER MAY FROM TIME TO TIME CHANGE THE DESIGN OF ITS PRODUCTS. NOTHING CONTAINED IN THIS WARRANTY SHALL BE CONSTRUED AS OBLIGATING WEBER TO INCORPORATE SUCH DESIGN CHANGES INTO PREVIOUSLY MANUFACTURED PRODUCTS, NOR SHALL SUCH CHANGES BE CONSTRUED AS AN ADMISSION THAT PREVIOUS DESIGNS WERE DEFECTIVE.

Weber-Stephen Products LLC
Customer Service Center
1415 S. Roselle Road
Palatine, IL 60067
U.S.A.

For replacement parts, call:
1-800-446-1071





A Rust-Resistant Griddle

A pre-seasoned carbon steel griddle with rust resistant finish provides superior rust resistance, making it always ready to cook right out of the box.

B Protective Hard Cover

The protective hard cover protects the cooking surface of the grill when not in use.

⚠ WARNING: Do not operate the grill with the hard cover closed. The hard cover is to be used for storage purposes only to protect the griddle.

C Even Heat Cook System

The precisely engineered cook system, provides unmatched even heat performance across the griddle.

D Digital Temperature Display

The digital temperature display provides an accurate display of the surface temperature to perfectly cook your food (*select models only*).

E Grease Management System

Grease and food debris can be scraped into the hole in the corner of the cooking surface, and into the front facing disposable drip pan located under the griddle. Simply remove the catch tray and replace the drip pan as needed.

F Flip-Up Table

The flip-up table provides additional workspace when you need it most – perfect when cooking for larger events (*select models only*).

G Clean, Confident Storage

Pull out, easy access, weather resistant bins make it extra convenient to store all your griddle tools outside (*select models only*).

H WEBER WORKS™ Prep, Cook, and Store System

With the WEBER WORKS™ Prep, Cook, and Store System you can keep cooking and cleaning supplies handy, carry food and condiments from the kitchen to the griddle, convert the side table into a prep station and stow gear in tightly sealed containers (*additional accessories sold separately at weber.com*) (*select models only*).

I Organized, Closed Cabinet Storage

Organizing racks allow for bins to be neatly stored inside the cabinet (*select models only*).

* The grills illustrated in this Owner's Manual may vary slightly from the model purchased.

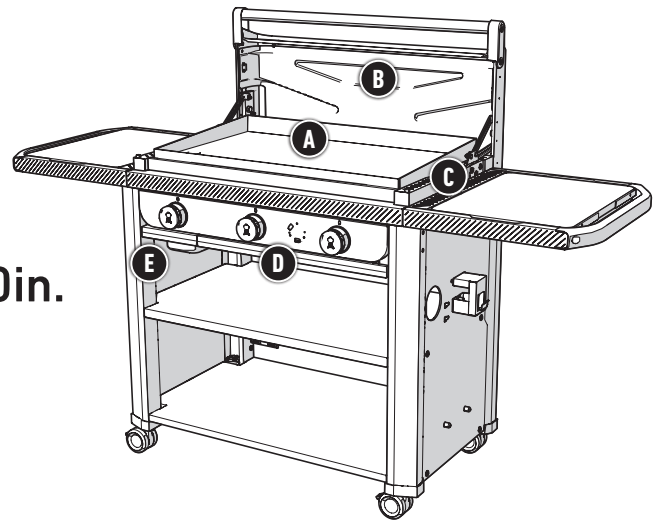

30in.

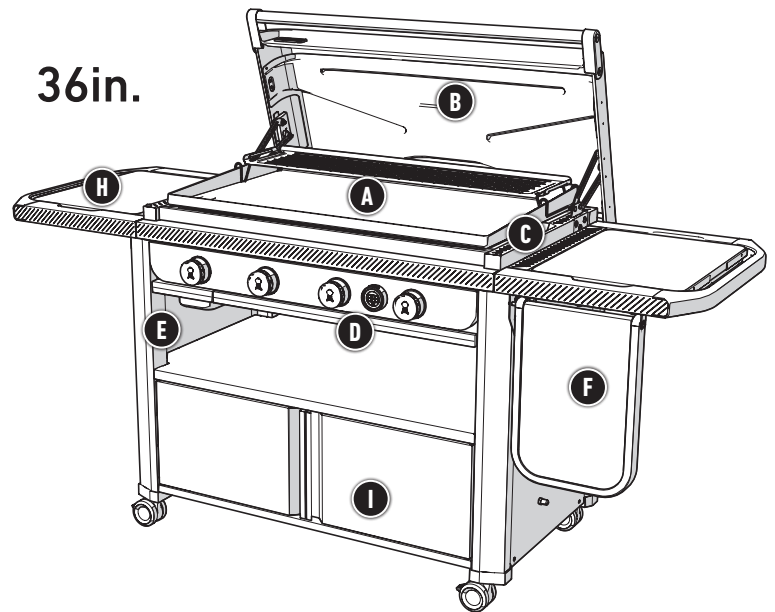

36in.

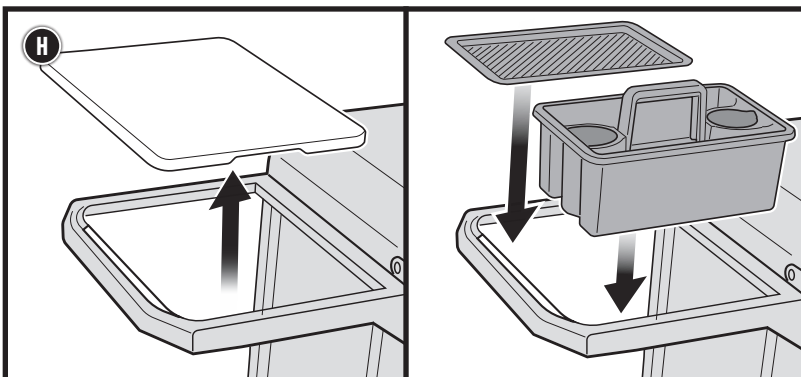
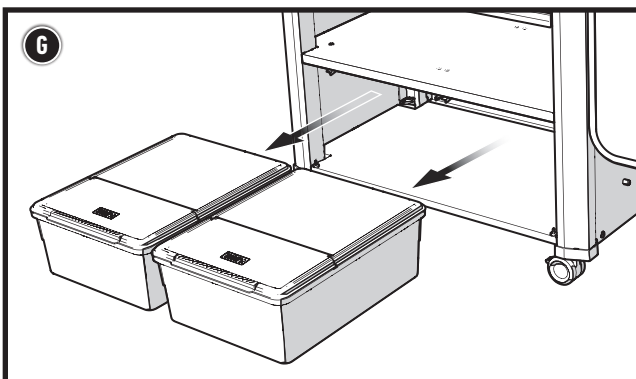



GETTING STARTED

Important Information about LP Gas & Gas Connections

What Is LP Gas?

Liquefied petroleum gas, also called LP, LP gas, liquid propane, or simply propane or butane, is the flammable, petroleum-based product used to fuel your grill. It is a gas at moderate temperatures and pressure when it is not contained. But at moderate pressure inside a container, such as a tank, LP is a liquid. As pressure is released from the tank, the liquid readily vaporizes and becomes gas.

Safe Handling Tips For LP Tanks

- A dented or rusty liquid propane tank may be hazardous and should be checked by your liquid propane supplier. Do not use a liquid propane tank with a damaged valve.
- Although your liquid propane tank may appear to be empty, gas may still be present, and the tank should be transported and stored accordingly.
- The LP tank must be installed, transported, and stored in an upright, secure position. LP tanks should not be dropped or handled roughly.
- Never store or transport the LP tank where temperatures can reach 125° F (51.7° C) (the tank will become too hot to hold by hand).
- Place dust cap on cylinder valve outlet whenever the cylinder is not in use. Only install the type of dust cap on the cylinder valve outlet that is provided with the cylinder valve. Other types of caps or plugs may result in leakage of propane.

LP Tank Requirements

- The tank must be approximately 18½ inches (46.35 cm) high and 12¼ inches (31.1 cm) in diameter with a marked 20 pound (9.07 kg) LPG capacity or 47.6 pound (21.6 kg) water capacity as stated by the manufacturer. Other tanks may be acceptable provided they are compatible with the grill retention means (tank scale).
- The tank used must be constructed and marked in accordance with the Specifications for LP gas Cylinders of the U.S. Department of Transportation (D.O.T.); or the Canadian Standard for Cylinders, Spheres and Tubes for Transportation of Dangerous Goods and Commission, CAN/CSA-B339, as applicable.
- Tanks must be provided with a listed OPD (Overfilling Prevention Device) and a Type 1 (CGA 791) tank connection. The tank connection must be compatible with the grill connection.
- The tank must include a collar to protect the tank valve.
- Tanks must have a D.O.T. certification (A), and a testing date (B) that is within five years of current use.

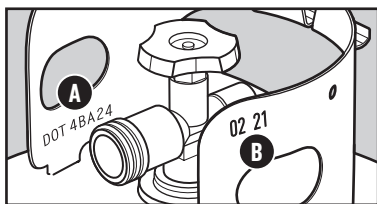

⚠ **WARNING:** It may be hazardous to attempt to fit other types of gas containers.

⚠ **IMPORTANT:** We recommend that you replace the gas hose assembly on your gas grill every five years. Some countries may have requirements that the gas hose be replaced within less than five years, in which case that country's requirement would take precedence.

For replacement hose, regulator, and valve assemblies, contact the Customer Service Representative in your area using the contact information on our web site. Log on to weber.com.

⚠ This appliance is not suitable for installation or connection to a reticulated gas supply.

LP Tank Installation

The tank is hung onto the tank bracket which is located on the right side of grill. The shape of the collar assembly (the metal protective ring around the tank valve) determines one of two directions in which the tank will correctly hang on the tank bracket (A).

Inspect the Tank

- 1) Confirm that the tank valve is fully closed. Close by turning valve clockwise.
- 2) Confirm that the tank valve is the proper mating type for the regulator (B).
- 3) Inspect the tank valve, including the internal rubber seal for damage or debris (C). If damaged, return tank to local retailer.

Install The Tank

- 1) Check that all burner control knobs are in the off \bigcirc position. Check by pushing in and turning knobs clockwise.
- 2) The tank is hung by the collar assembly (the metal protective ring around the tank valve) onto the tank bracket (D).
- 3) Screw the regulator coupling onto the tank valve, turning clockwise. Hand-tighten only. Using a wrench could damage the regulator coupling and could cause a leak. Proceed to "CHECKING FOR GAS LEAKS."

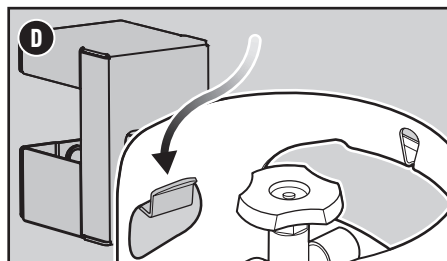
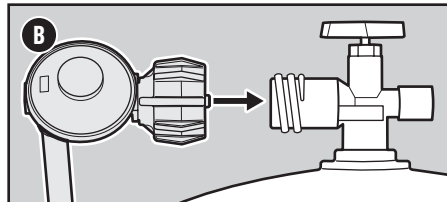
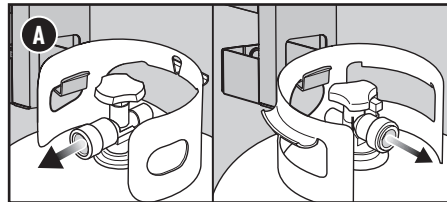

Refilling or Replacing an LP Tank

How Much Fuel is in the Tank?

This feature is only available on select models.

The tank scale indicates the amount of fuel in a standard 20 pound (9.07 kg) tank once the tank is hung from the scale. The fuel level is checked by viewing the indicator line located on the scale inside of the cabinet. Some models include an indicator on the front of the grill. The indicator points to a full tank (A), and gradually moves to indicate when the tank is empty (B) and needs to be removed to replace or refill.

Removal of the LP Tank

- 1) Make sure the grill is off and cool.
- 2) Confirm that the tank valve is fully closed. Close by turning valve clockwise.
- 3) Unscrew regulator coupling by turning counterclockwise by hand.
- 4) On the tank scale, loosen hand nut and rotate tank lock up.
- 5) Lift tank off tank hook.

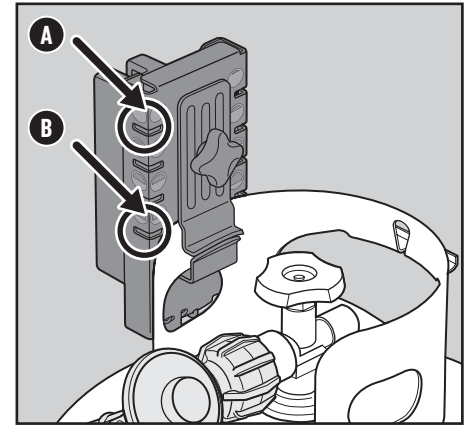

⚠ **DANGER:** Do not store a spare LP tank under or near this grill. Never fill the tank beyond 80% full. Failure to follow these statements exactly may result in a fire causing death or serious injury.

⚠ **WARNING:** Do not use a wrench to tighten the connection. Using a wrench could damage the regulator coupling and could cause a leak.

⚠ **CAUTION:** Use cylinders that are marked "Propane" only.



Leak Checking

What is a Leak Check?

Once the LP tank is properly installed, it is necessary to perform a leak check. A leak check is a reliable way to verify that gas is not escaping after you connect the tank. The fuel system in your grill features factory-made connections that have been thoroughly checked for gas leaks and the burners have been flame-tested. WEBER recommends performing a thorough leak check after assembly, as well as annually. The following fittings should be tested:

- Where the regulator connects to the tank.
- Where the gas hose connects to the bulkhead.
- Where the bulkhead connects to the corrugated gas line.

Checking for Gas Leaks

- 1) Wet fittings (A) with a soap and water solution, using a spray bottle, brush, or rag. You can make your own soap and water solution by mixing 20% liquid soap with 80% water; or, you can purchase leak check solution in the plumbing section of any hardware store.
- 2) Slowly open gas supply by turning tank valve counterclockwise while checking for bubbles.
- 3) If bubbles appear there is a leak:
 - a) If the leak is at the cylinder (B), turn off the gas. **DO NOT OPERATE THE GRILL.** Disconnect the tank and return the tank to your local retailer.
 - b) If the leak is at the regulator (C), turn off the gas (D). **NEVER ATTEMPT TO TIGHTEN THE REGULATOR WITH TANK VALVE OPEN. DO NOT OPERATE THE GRILL.** Contact the Customer Service Representative in your area using the contact information on our website.
 - c) If the leak is at any fittings indicated in illustration (D), re-tighten fitting with a wrench and recheck for leaks with soap and water solution. If leak persists, turn off the gas. **DO NOT OPERATE THE GRILL.**
 - d) If the leak is at any fittings indicated in illustration (E), turn off the gas. **DO NOT OPERATE THE GRILL.**
- 4) If bubbles do not appear, leak checking is complete:
 - a) Turn the gas supply off at the tank and rinse connections with water.

NOTE: Since some leak test solutions, including soap and water, may be slightly corrosive, all connections should be rinsed with water after checking for leaks.

Additional Leak Check Precautions

The following fittings should be tested for gas leaks each time a tank is refilled and reinstalled:

- Where the regulator connects to the tank (B) and at the regulator (C).

Follow the instructions for "Checking for Gas Leaks".

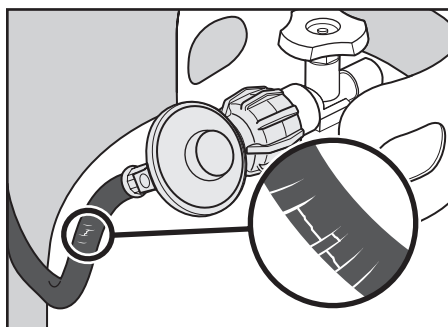
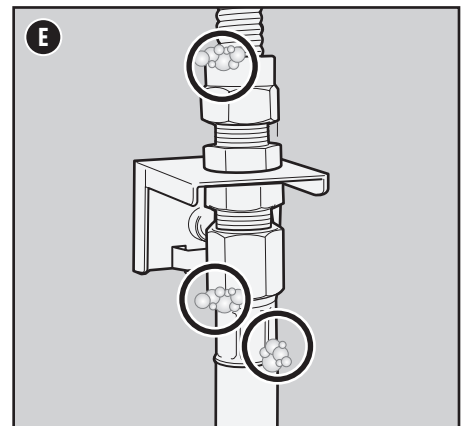
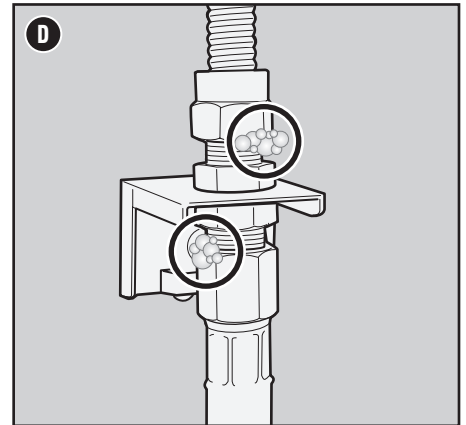
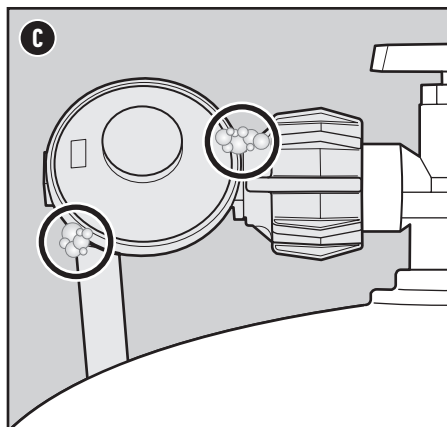
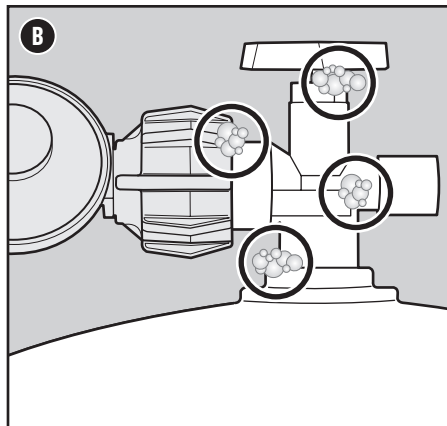
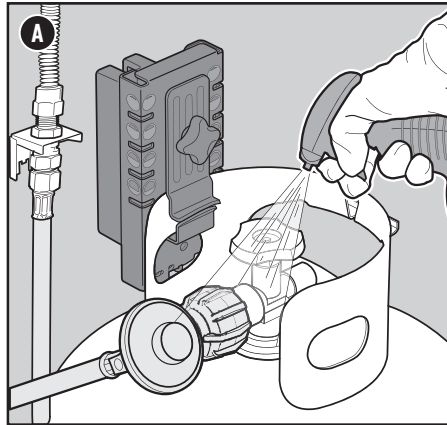

- ⚠ **DANGER:** Do not use a flame to check for gas leaks. Be sure there are no sparks or open flames in the area while you check for leaks.
- ⚠ **DANGER:** Leaking gas may cause a fire or explosion.
- ⚠ **DANGER:** Do not operate the grill if there is a gas leak present.
- ⚠ **DANGER:** If you see, smell, or hear the hiss of gas escaping from the liquid propane tank:
 - 1) Move away from liquid propane tank.
 - 2) Do not attempt to correct the problem yourself.
 - 3) Call your fire department.
- ⚠ **DANGER:** Always close the tank valve before disconnecting the regulator. Do not attempt to disconnect the gas regulator and hose assembly or any gas fitting while this grill is in operation.
- ⚠ **DANGER:** Do not store a spare LP tank under or near this grill. Never fill the tank beyond 80% full. Failure to follow these statements exactly may result in a fire causing death or serious injury.
- ⚠ **WARNING:** If the hose is found to be damaged in any way, do not use the grill. Replace using only WEBER authorized replacement hose.

⚠ **WARNING:** If the hose is found to be damaged in any way, do not use the grill. Replace using only WEBER authorized replacement hose.



OPERATION

Igniting the Grill

Using the Snap Ignition System to Ignite Burners

Each control knob snap igniter creates a spark from the igniter electrode to the burner lighting tube. You generate the energy for the spark by pushing in the control knob and turning it to the start/high position. Each control knob operates an individual burner, and each burner ignites independently. Ignite the burners starting from left to right. All burners should be lit for preheating, however, all burners do not have to be lit while cooking.

1) Open the protective hard cover (A).

⚠ WARNING: Do not operate the grill with the hard cover closed. The hard cover is to be used for storage purposes only to protect the griddle.

2) Check that all burner control knobs are in the off position. Check by pushing in and turning knobs clockwise (B).

Note: It is important that all burner control knobs are in the off position before turning on the LP tank. If they are not, the flow limiting device built into the regulator will activate, limiting the flow of gas from the LP tank.

3) Turn the LP tank on by slowly turning the tank valve counterclockwise; wait 60 seconds (C).

Note: It is important that the LP tank is turned on slowly. If it is opened too quickly, the flow limiting device built into the regulator will activate, limiting the flow of gas from the LP tank.

4) Begin with the burner furthest to the left. Push the burner control knob in (D) and turn it counterclockwise to the start/high position until you hear it snap (E). Continue to hold the control knob in for two seconds after you hear the snap. This action will spark the igniter and light the burner.

5) Check that the burner is lit by looking through the space in between the cooking surface and the control panel.

6) If the burner does not ignite, turn burner control knob to the off position and repeat the lighting procedure a second time. If the burner still does not light, turn the burner control knob to OFF and wait five minutes to let the gas clear before you try again or try to light with a match.

7) If the burner ignites, repeat steps 4 through 6 to light the remaining burners.

Should the burners fail to ignite using the snap ignition, refer to the TROUBLESHOOTING section in this Owner's Guide. There you will find instructions on igniting the grill with a match to help determine the exact problem.

Preheat the Griddle

Preheating the griddle is critical to successful cooking. It helps prevent food from sticking, and ensures the griddle is hot enough to properly cook your food. It also helps burn off any residue of a previously cooked meal.

1. Open the protective hard cover.

2. Ignite your griddle according to the ignition instructions in this Owner's Manual.

3. Preheat the griddle for 10 minutes. WEBER recommends preheating the griddle to the temperature you want to cook at (i.e. if you're cooking pancakes, preheat on **LOW**. If you're cooking smash burgers, preheat on **HIGH**).

To Extinguish Burners

1) Push each burner control knob in and then turn clockwise all the way to the off position.

2) Turn gas supply off at the LP tank.

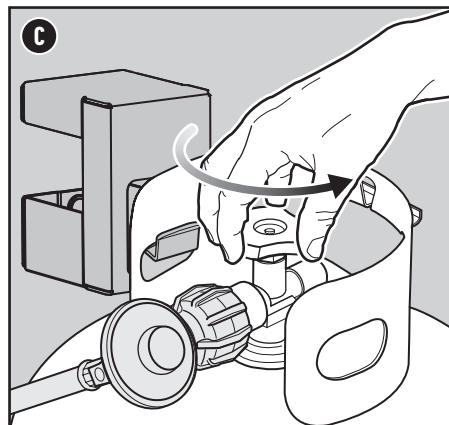
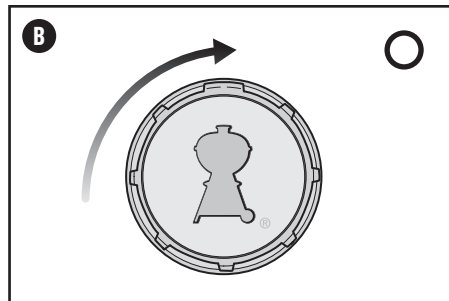
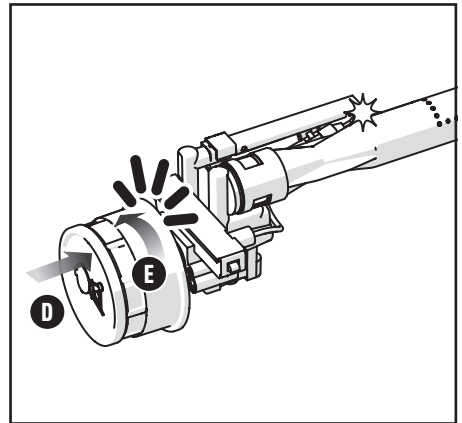
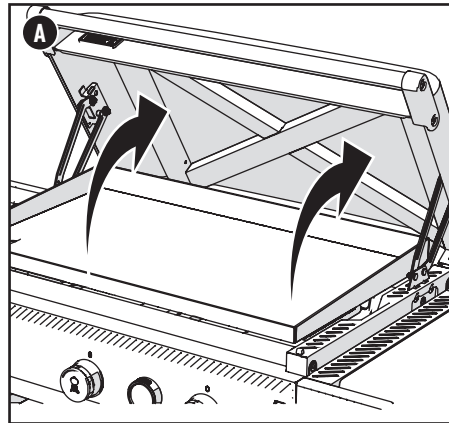

⚠ WARNING: The burner control knobs must be in the OFF position before turning on the liquid propane tank valve. If they are not in the OFF position, when you turn on the LP tank valve, the "excess gas flow control" feature will activate, limiting the flow of gas from the LP tank. If this should occur, turn off the LP tank valve and burner control knobs. Start over.

⚠ DANGER: When the "excess gas flow control" feature is activated, a small amount of gas is still flowing to the burners. After turning off the tank and burner control knobs, wait at least five minutes for the gas to clear before attempting to light the grill. Failure to do so may result in an explosive flare-up, which can cause serious bodily injury or death.

⚠ WARNING: Do not operate the grill with the protective hard cover closed. The protective hard cover is to be used for storage purposes only to protect the griddle.

⚠ WARNING: Open protective hard cover during ignition. Failure to open the protective hard cover while igniting the grill's burners, or not waiting five minutes to allow the gas to clear if the grill does not light, may result in an explosive flare-up which can cause serious bodily injury or death.

⚠ WARNING: Do not lean over open grill while igniting or cooking.

⚠ WARNING: Each burner must be ignited individually using the snap ignition.

⚠ WARNING: If ignition does not occur within four seconds of attempting to light the first burner, turn the burner control knob to the off position and repeat the lighting procedure a second time. If the burner still does not light, turn the burner control knob to OFF and wait five minutes to let the gas clear before you try again or try to light with a match.

Burner Control Knob Settings





Before You Cook

Your griddle surface has a special rust resistant finish applied to the metal surface and has been pre-seasoned with a food-grade oil to provide rust protection. Therefore, initial seasoning is not required but if you choose to add another layer of seasoning to your griddle, please see seasoning instructions below.

For continued griddle maintenance you should continue to scrape and season your griddle every 2 to 3 cooking sessions to keep your griddle in good condition. For more information about caring for your griddle, scan the QR code:



Tools Needed: Tongs, lint-free paper towels or cotton cloth, neutral cooking oil.

For optimal results, you may want to add another layer of seasoning to your griddle. Please see seasoning instructions below.

1. Open the protective hard cover.

⚠ WARNING: Do not operate the grill with the hard cover closed. The hard cover is to be used for storage purposes only to protect the griddle.

2. With the griddle in place on the grill, handwash the griddle, rinse, and thoroughly dry.

NOTE: The griddle must be **COMPLETELY** dry before continuing the seasoning process.

NOTE: This will be the **ONLY TIME** you use soapy water on your griddle.

3. Pour ¼ cup of a neutral oil (i.e. canola oil, vegetable oil, grapeseed oil) into a bowl.

4. Dip a paper towel or cotton cloth into the bowl (A), squeezing off the excess oil. Wipe the griddle from side to side, top to bottom as evenly as possible (B). Be sure to get the interior and exterior sides of the griddle as well. Wipe away any excess oil with a clean paper towel or cotton cloth if necessary.

5. Light all of the burners and preheat your griddle on the high temperature setting (C). The surface will begin to smoke and darken (approximately 10 minutes). If any oil begins to bead on the surface, use grill mitts and tongs to wipe the excess oil from the griddle (D).

NOTE: By the end of the seasoning process, a well-seasoned griddle will be dark from edge to edge.

6. The surface will darken and begin to smoke. When the surface stops smoking (additional 20 minutes), turn off the grill.

⚠ IMPORTANT: Allow the griddle to cool completely, approx. 30 minutes.

7. The griddle now has 1 coat of seasoning. You should continue to scrape and season your griddle every 2 to 3 cooking sessions to keep your griddle in good condition.

Scan this QR code for more information on seasoning your griddle:

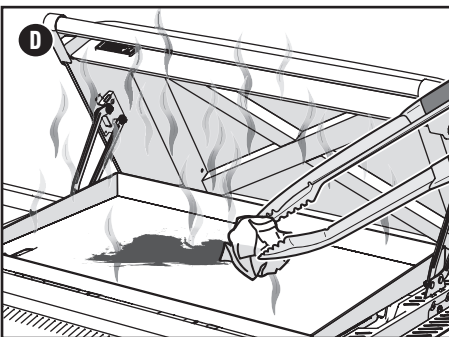
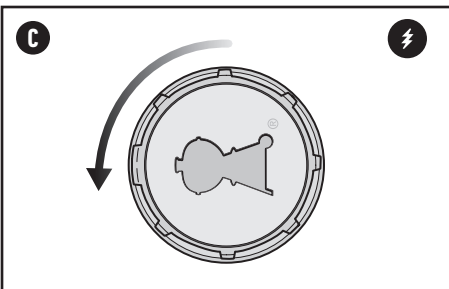
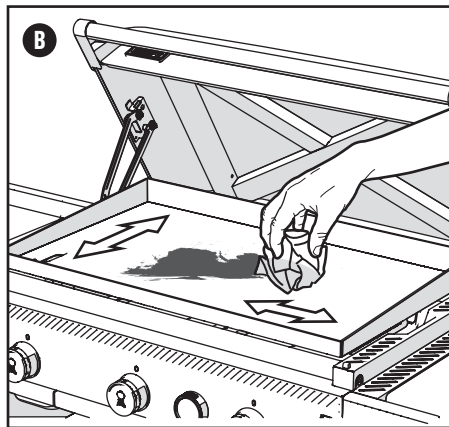
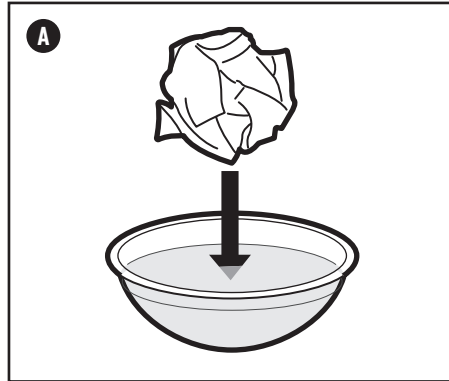

Digital Temperature Display

This feature is only available on select models.

The digital temperature display gives you a convenient way to check the surface temperature of your griddle. While the grill is in use, please follow these instructions for using the digital temperature display:

Turning the Display ON

1) Press and hold the power button for 2 seconds, located on the top-left side, to turn on the display.

NOTE: The grill should always be pre-heated for 10 min or more. If display is turned on when the grill is off, display lights will cycle through a startup sequence for the first 4 minutes while the griddle temperature is registering with the display. If display is turned on after grill is lit, the display will automatically show the griddle temperature.

2) If you want to change between Fahrenheit (F°) and Celsius (C°), push the top-right button on the display unit to toggle between these options.

Brightness

Once powered on, the display will be at 100% brightness for 15 minutes, then will dim slightly to preserve battery life. To refresh the display to 100% brightness simply tap the power button, located on the top-left side, and the display unit will update to 100% brightness for 2 minutes.

Batteries

When it is time to change the 2 AA batteries, a low battery icon will appear at the bottom of the display screen. Use alkaline batteries only. Do not mix old and new batteries or different types of batteries (standard, alkaline, or rechargeable).



Turning the Display OFF

1) To manually shut off, press and hold the power button, located on the top-left side, for 2 seconds.

NOTE: The display will automatically turn off after no heat has been detected for 4 minutes or the grill has completely cooled.

Error Code: E-8: If there is a detached thermocouple, "E-8" will be shown on display. Please contact WEBER Customer Service for assistance.

⚠ DANGER: Do not line the slide-out grease tray or cookbox with aluminum foil.

⚠ DANGER: Check the slide-out grease tray and catch pan for grease build-up before each use. Remove excess grease to avoid a grease fire.

⚠ WARNING: Use caution when removing catch pan and disposing of hot grease.

⚠ WARNING: Use heat-resistant barbecue mitts or gloves when operating grill.

⚠ WARNING: Keep ventilation openings around tank clear and free of debris.

⚠ WARNING: Keep any electrical supply cord and the fuel supply hose away from heated surfaces.

⚠ WARNING: If the hose is found to be damaged in any way, do not use the grill. Replace using only WEBER authorized replacement hose.

⚠ WARNING: Objects placed near the griddle will become hot.

⚠ WARNING: Keep paper towels away from direct flames or extreme heat.

⚠ WARNING: DO NOT remove the griddle until the grill is off and is completely cool.

⚠ CAUTION: Never apply large amounts of cold water across the whole griddle surface at once. This may cause griddle to warp.

⚠ CAUTION: Adding a large amount of cold or frozen food (or food with significant water content) to a hot griddle may cause griddle to warp.

⚠ CAUTION: Do not spray cold water on the cooking surface while cooking.

⚠ CAUTION: Use caution when turning or flipping food while cooking to avoid splashing hot grease.



OPERATION

Tips For Cooking

Tame the Heat

Your WEBER SLATE's cooking surface is fantastic at generating heat – and maintaining that heat – even when it's loaded with food. Because it's so good at holding onto heat, it can take a while to cool down. So, we suggest starting at lower temperatures when you're first getting used to cooking on the griddle. Getting your grill hotter is easy, it's getting it to cool down that takes time.

Dial In The Perfect Temperature

LOW HEAT: If you want your food to cook through without getting too crispy or browned, start with low heat. It's great for eggs, pancakes, and delicate seafood, or for thicker cuts of meat that will take an extra-long time to cook.

MEDIUM HEAT: Perfect for when you want to get that perfect, golden-brown sear, but need a little extra time to make sure your food is cooked all the way through. Use medium heat on chicken breasts or thighs, thicker steaks, seafood, or most vegetables.

HIGH HEAT: When you need that crispy browned crust on your smashed burger, or you're wowing the family with your hibachi skills, you need to do it on high heat. Use high heat on thinner cuts of meat that dry out quickly but would benefit from seared flavor. It's great for fajitas, stir fries, thinner steaks, and smashed burgers.

NOTE: You can use one or two burners, instead of all burners simultaneously, to create different heat zones on the griddle.

Every Time You Cook

Meal-to-Meal Maintenance

The Meal-To-Meal Maintenance plan includes the following simple, yet important steps that should always be performed prior to cooking.

Check for Grease

Your griddle was built with a grease management system that collects grease and food debris into a disposable container. The grease and food debris is channeled into a disposable drip pan that lines the grease tray. This system should be cleaned before you move your grill or cook to prevent grease fires.

1. Confirm that the grill is off and completely cooled.
2. Remove any excess grease or food debris with a scraper and wipe the griddle clean with a paper towel. Scrape the grease and food debris down through the opening on the flat top cooking surface into the disposable drip pan below (A).
3. Remove the grease tray (B). Check for excessive amounts of grease and food debris in the disposable drip pan that lines the grease tray. Discard the disposable drip pan when necessary and replace it with a new one.
4. Reinstall all components.

Inspect the Hose

Routine inspection of the hose is necessary to ensure safety and proper operation of your griddle.

1. Confirm that the griddle is off and completely cooled.
2. Check the hose for any signs of cracking, abrasions, or cuts (C). If the hose is found to be damaged in any way, do not use the griddle. Contact WEBER customer service for a replacement hose.

Preheat the Griddle

Preheating the griddle is critical to successful cooking. It helps prevent food from sticking, and ensures the griddle is hot enough to properly cook your food. It also helps burn off any residue of a previously cooked meal.

1. Open the protective hard cover.
2. Ignite your griddle according to the ignition instructions in this Owner's Manual.
3. Preheat griddle on HIGH for 10-15 minutes depending on conditions such as air temperature and wind. After preheating, you can adjust the burner(s) as desired.

Temperature Setting	Food
Low	<p>Eggs - Sunny side up, over-easy, scrambled</p> <p>Vegetables - Sautéing onions, peppers, garlic</p> <p>Thicker Proteins - thicker steaks, rendering duck breast or bacon fat</p> <p>Breads - French toast, pancakes, crepes, grilled cheese</p>
Medium	<p>Proteins - Ground beef, chicken, pork chops, fish, steaks</p> <p>Vegetables - Browning/Roasting brussel sprouts, zucchini, squash, hasbrowns, corn</p> <p>Breads - Baking flatbreads or naan, paninis</p>
High	<p>Proteins - Searing steaks, smashed burgers, stir-fry shrimp, fried rice, browning tofu</p> <p>Vegetables - Charring/blistering peppers, broccoli, mushrooms, stir-frying peppers, asparagus, onions</p>

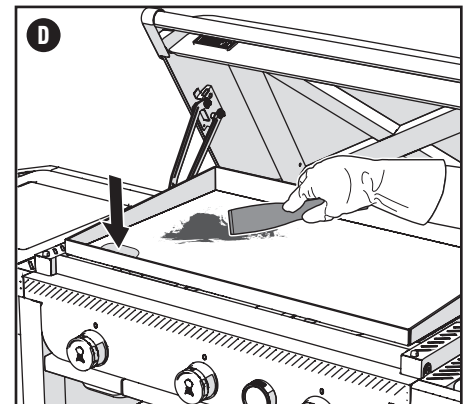
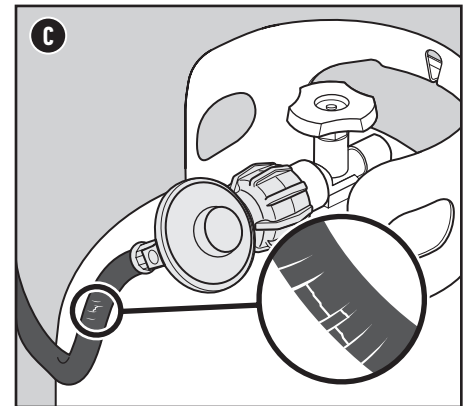
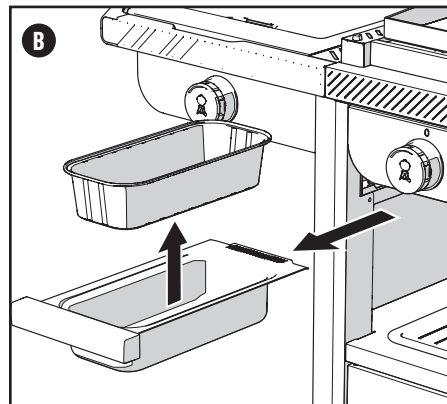
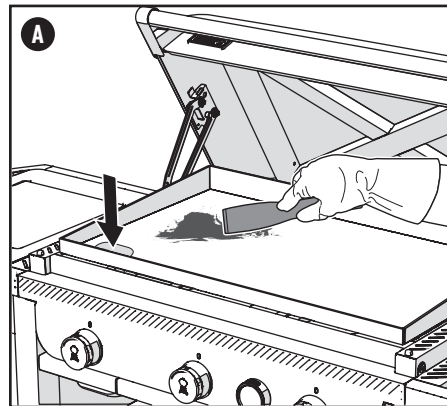

Clean the Cooking Surface

After preheating, leftover food and grease from previous use will be easier to remove with a scraper if needed.

1. Scrape the cooking surface with a scraper after preheating (D). Direct any leftover grease or food into the hole in the griddle's cooking surface.



Cleaning and Maintenance

Cleaning and Maintaining the Griddle

The griddle surface should be cleaned after each use to preserve it and continue to ensure a non-stick cooking surface. Follow these steps for a proper cleaning:

1. After the grill is off and cooled for 5 minutes, use a scraper or spatula to scrape excess grease, oil, and food debris into the hole in the griddle.

NOTE: For stubborn, stuck on food debris, a small amount of room temperature water can be used during the scraping process. DO NOT USE LARGE AMOUNTS COLD WATER WHILE CLEANING THE GRIDDLE.

2. Using several paper towels, wipe and dry the griddle's surface, directing any excess grease, oil, and food debris into the hole in the griddle.
3. Apply small amounts of a neutral cooking oil such as vegetable or canola across the griddle's surface.
4. Using paper towels, rub the oil evenly around the entire cooking surface. Use more paper towels if needed to wipe up any excess pools of oil.

Cleaning the Burners

Two areas on the burners that are key to optimum performance are the ports (small openings running along the length of the burners) and the spider/insect screens on the front ends of the burners. Keeping these areas clean is essential for safe operation.

Cleaning the Burner Ports

- 1) Once the grill has been turned off and cooled, and the LP tank has been disconnected, using BBQ mitts or gloves remove the griddle and set aside.
- 2) Use a clean stainless steel bristle grill brush to clean the outside of the burners by brushing across the burner ports.

Cleaning the Spider Screens

To access the spider/insect screens, it is necessary to remove the control panel (A). Follow these steps for removing the control panel:

- 1) Remove the slide out grease tray and set aside.
- 2) Remove the control knobs and set aside.
- 3) Remove the red control panel trim by sliding it to the left and pulling it away from the bottom of the control panel.
- 4) Remove the 2 screws that hold the control panel to the grill frame and set aside.
- 5) Remove the control panel by pulling it up off of the hanging tabs and set it aside.
- 6) Clean the spider/insect screens on the ends of the burner tubes using a soft bristle brush (B).
- 7) Re-install all components.

NOTE: Ensure the digital thermometer wires are connected before reassembly. (Only available on select models).

Cleaning the Grill Frame

The outside of your grill may include stainless steel, porcelain-enameled, and plastic surfaces. WEBER recommends the following methods based on the surface type:

Cleaning Stainless Steel Surfaces

Clean stainless steel using a non-toxic, non-abrasive stainless steel cleaner or polish designed for use on outdoor products and grills. Use a microfiber cloth to clean in the direction of the grain of the stainless steel. Do not use paper towels.

NOTE: Do not risk scratching your stainless steel with abrasive pastes. Pastes do not clean or polish. They will change the color of the metal by removing the top chromium oxide film coating.

Cleaning Painted, Porcelain-Enameled Surfaces and Plastic Components

Clean painted, porcelain-enameled and plastic components with warm soapy water, and paper towels or cloth. After wiping down the surfaces, rinse and dry thoroughly.

Cleaning the Outside of Grills that are in Unique Environments

If your grill is subject to a particularly harsh environment, you will want to clean the outside more often. Acid rain, pool chemicals, and salt water can cause surface rusting to appear. Wipe down the outside of your grill with warm soapy water. Follow up with a rinse and thorough drying. Additionally, you may want to apply a stainless steel cleaner weekly to prevent surface rust.

Check for Grease

Your griddle was built with a grease management system that collects grease and food debris into a disposable container. The grease and food debris is channeled into a disposable drip pan that lines the grease tray. This system should be cleaned before you cook to prevent grease fires.

1. Confirm that the grill is off and completely cooled.
2. Remove any excess grease or food debris with a scraper and wipe the griddle clean with a paper towel. Scrape the grease and food debris down through the opening on the flat top cooking surface into the disposable drip pan below.
3. Remove the grease tray. Check for excessive amounts of grease and food debris in the disposable drip pan that lines the grease tray. Discard the disposable drip pan when necessary and replace it with a new one.
4. Reinstall all components.

NOTE: In the event of severe weather, water may enter the grease tray and disposable drip pan. Check the disposable drip pan and grease tray for water and empty when necessary.

Clean the Cooking Surface

After preheating, leftover food and grease from previous use will be easier to remove with a scraper if needed.

1. Scrape the cooking surface with a scraper after preheating. Direct any leftover grease or food into the hole in the griddle's cooking surface.

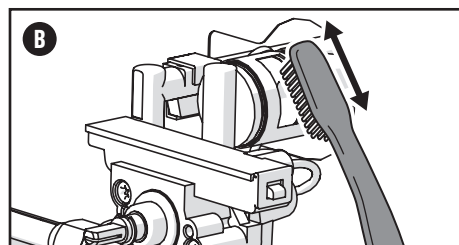
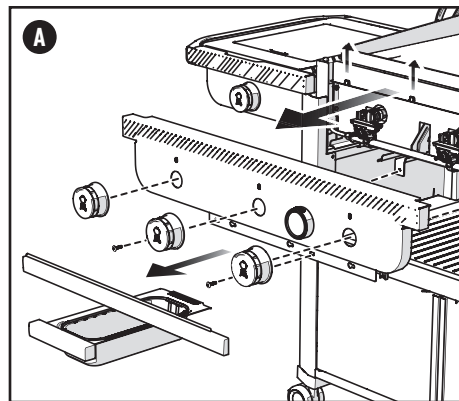

⚠ WARNING: Turn your grill off and wait for it to cool before thoroughly cleaning.

⚠ WARNING: When cleaning the burners, never use a brush that has already been used to clean the cooking grates. Never put sharp objects into the burner port holes.

⚠ CAUTION: Do not use any of the following to clean your grill: abrasive stainless steel polishes or paints, cleaners that contain acid, mineral spirits or xylene, oven cleaner, abrasive cleansers (kitchen cleansers), or abrasive cleaning pads.

Proper Burner Flame Pattern

The burner in your grill is factory set for the correct air and gas mixture. When the burner is performing correctly, you will see a specific flame pattern. The tips may occasionally flicker yellow (A), with a descending light blue (B) to dark blue flame (C).

⚠ WARNING: Blocked and dirty ports can restrict full gas flow, resulting in a fire (D) in and around the gas valves, causing serious damage to your grill.

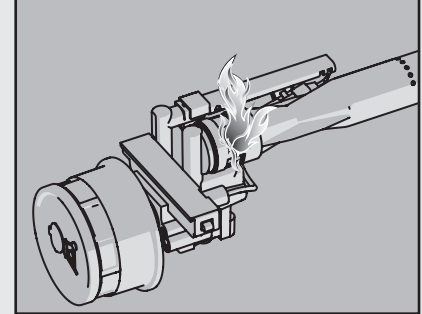
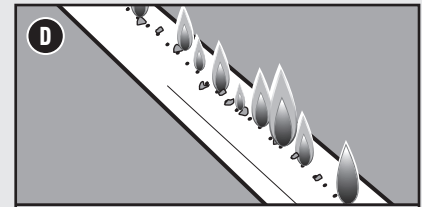
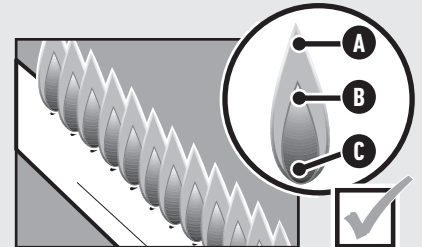

Spider Screens

The combustion air openings of the burners (E) are fitted with stainless steel screens to prevent spiders and other insects from spinning webs and building nests inside the burners. Additionally, dust and debris can accumulate on the outside of the spider/insect screen and obstruct the oxygen flow to the burners.

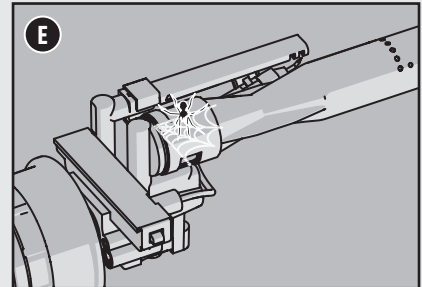

⚠ WARNING: Do not attempt to make any repair to gas carrying, gas burning, ignition components or structural components without contacting Weber-Stephen Products LLC, Customer Service Department.

⚠ CAUTION: The burner tube openings must be positioned properly over the valve orifices.



TROUBLESHOOTING

GAS FLOW

SYMPTOM

- Grill does not reach desired temperature or heats unevenly.
- One or more of the burners fail to ignite.
- Flame is low when burner is on high position.
- Flames do not run the whole length of the burner.
- Burner flame pattern is erratic.

CAUSE

The "flow limiting device" has been activated. This safety feature built into the regulator restricts the gas flow in the event of a gas leak. You can inadvertently activate this safety feature without having a gas leak. This typically occurs when you turn on the gas at the LP tank and one or more of the control knobs are not in the off position. It may also occur if you turn on the LP tank too quickly.

SOLUTION

Reset the "flow limiting device" by closing the LP tank valve and turning all the burner control knobs to the off  position. Wait five minutes to allow accumulated gas to dissipate, then ignite the grill again following the instructions in the "Operation" section.

.....
The LP tank is low or empty.

Refill LP tank.

.....
Fuel hose is bent or kinked.

Straighten fuel hose.

.....
Burner ports are dirty.

Clean burner ports. Refer to "Cleaning the Burner Ports."

SYMPTOM

- Gas is smelled in conjunction with burner flames that appear yellow and lazy.

CAUSE

Spider screens on the burners are obstructed.

SOLUTION

Clean spider screens. Refer to "Cleaning the Spider Screens" in the "Cleaning and Maintenance" section. Also refer to the illustrations and information in this section about proper flame pattern and spider screens.

SYMPTOM

- The smell of gas and/or a light hissing sound.

CAUSE

The internal rubber seal in the LP tank valve could be damaged.

SOLUTION

Extinguish any open flame. Shut off the gas to the grill and disconnect the gas hose from the LP tank. Inspect the rubber seal in the LP tank valve for damage. If damaged, return tank to place of purchase.

.....
Connection between regulator and LP tank could be incomplete.

Extinguish any open flame. Shut off the gas to the grill. Refer to LP TANK INSTALLATION & LEAK CHECKING section of your owner's manual.

REPLACEMENT PARTS

To obtain replacement parts,
contact the local retailer
in your area or log onto weber.com.



MAIN BURNER(S) WILL NOT IGNITE

SYMPTOM

- Main burners do not ignite when following the ignition instructions in the “Operation” section of this owner’s manual.

CAUSE

There is a problem with gas flow.

SOLUTION

If any burner does not ignite, the first step is to determine if there is gas flowing to the burner(s). To check this, follow the instructions below for “Lighting Your Grill with a Match.”

If **match lighting IS NOT successful**, follow the instructions for disconnecting and reconnecting the LP tank..

There is a problem with the ignition system.

If any burner does not ignite, the first step is to determine if there is gas flowing to the burner(s). To check this, follow the instructions below for “Lighting Your Grill with a Match.”

If **match lighting IS successful**, contact customer service about checking the ignition system.

Lighting Your Grill with a Match

Using a Match to Determine if there is Gas Flow to the Main Burners

Matchstick holder is available on select models only.

- 1) Remove the protective hard cover.

⚠ WARNING: Do not operate the grill with the hard cover closed. The hard cover is to be used for storage purposes only to protect the griddle.

- 2) Check that all burner control knobs are in the off  position. Check by pushing in and turning knobs clockwise.

Note: It is important that all burner control knobs are in the off  position before turning on the LP tank. If they are not, the flow limiting device built into the regulator will activate, limiting the flow of gas from the LP tank.

- 3) Turn the LP tank on by slowly turning the tank valve counterclockwise; wait 60 seconds.

Note: It is important that the LP tank is turned on slowly. If it is opened too quickly, the flow limiting device built into the regulator will activate, limiting the flow of gas from the LP tank.

- 4) Begin with the burner furthest to the left. Put match in the matchstick holder and strike match. (Matchstick holder is located inside the rear right leg of the grill.) Insert lit match through the slot on the side of the griddle, next to the burner **(A)**.

- 5) Push the burner control knob in and slowly turn it counterclockwise to the start/high  position **(B)**.

- 6) Confirm that the burner is lit by looking between the griddle and the grill frame.

- 7) If the burner does not ignite within 4 seconds, turn burner control knob to the off  position and wait five minutes to allow the gas to clear before attempting to light the burner again. If repeated attempts fail, follow the gas flow troubleshooting instructions on the next page.

- 8) If the burner ignites, the problem may be with the ignition system. Contact WEBER customer service about checking the ignition system.

- 9) Replace the matchstick holder by hanging it inside the rear right leg of the grill **(C)**.

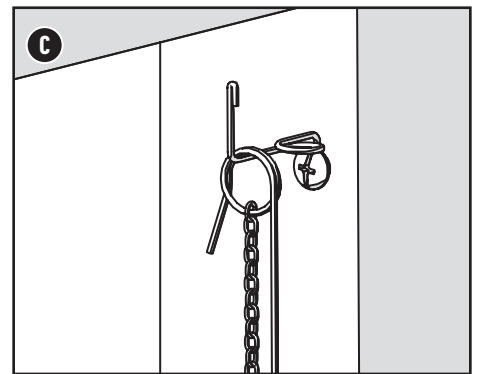
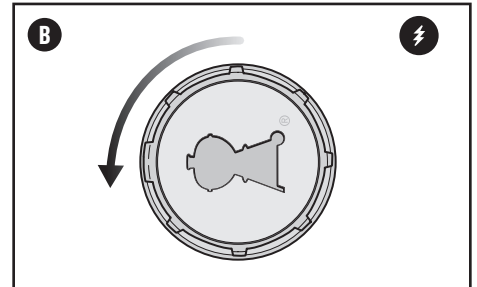
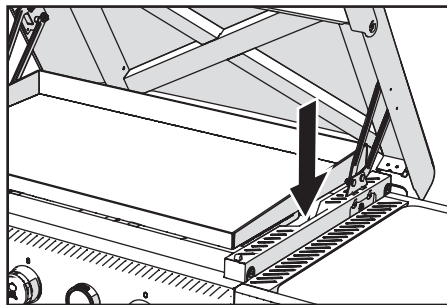
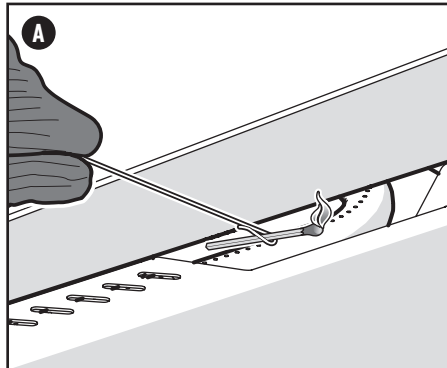

CALL CUSTOMER SERVICE

If you are still experiencing any problems, contact the Customer Service Representative in your area using the contact information on weber.com.



REPLACEMENT PARTS

SLATE - GP30 LP - US 020124

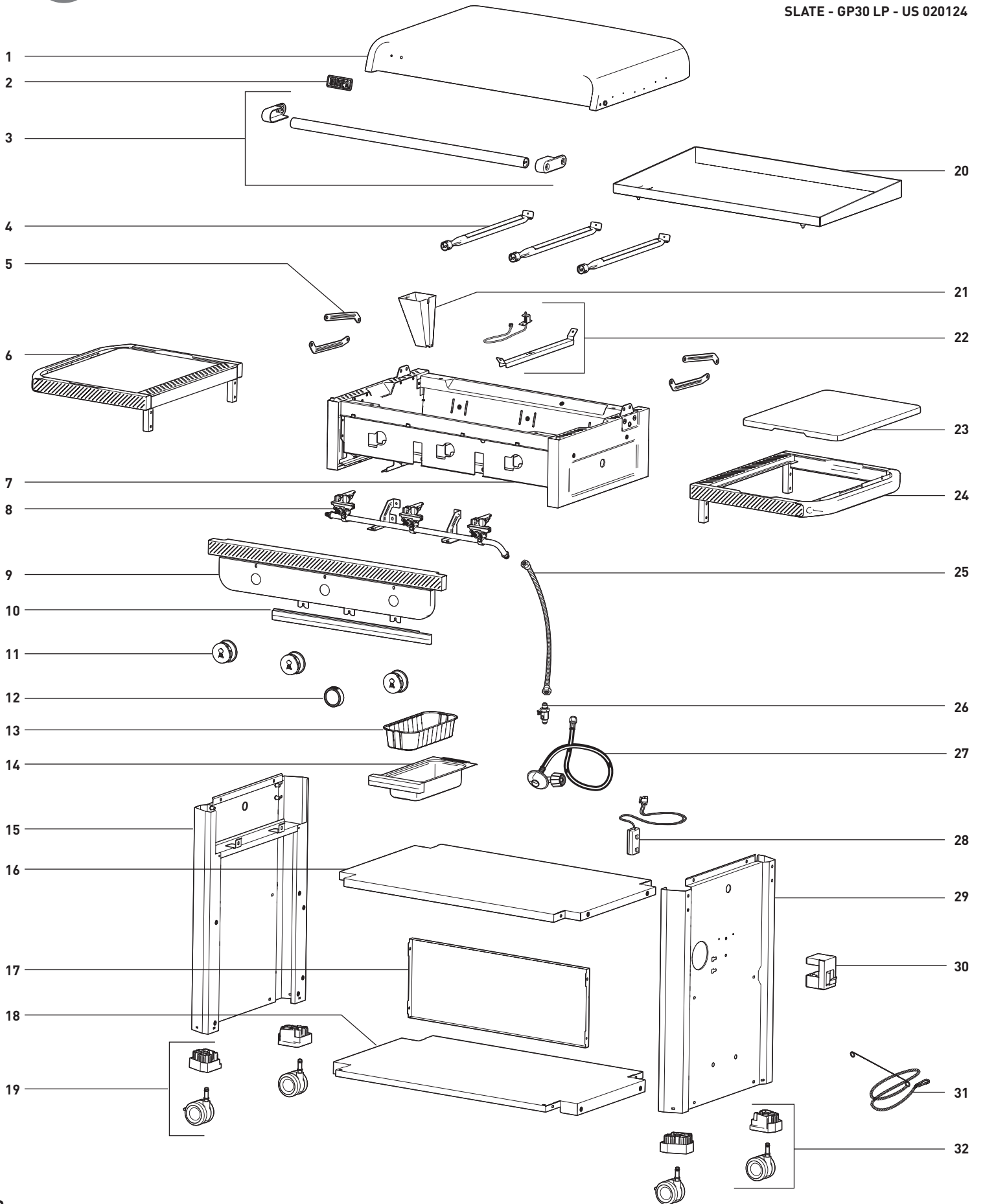

REPLACEMENT PARTS



SLATE - GPD30 LP - US 020124

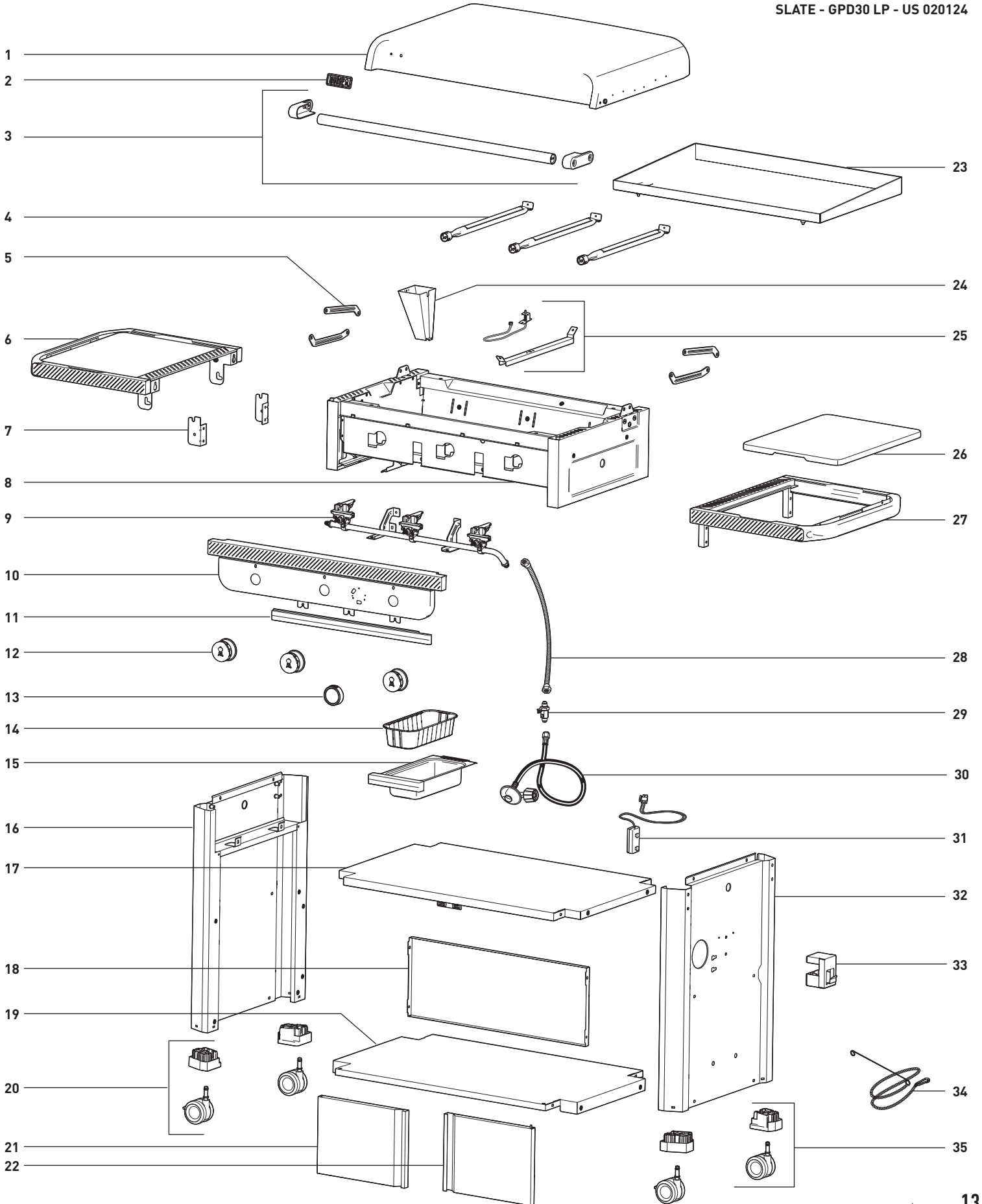



REPLACEMENT PARTS

SLATE - GPD30B LP - US 090323

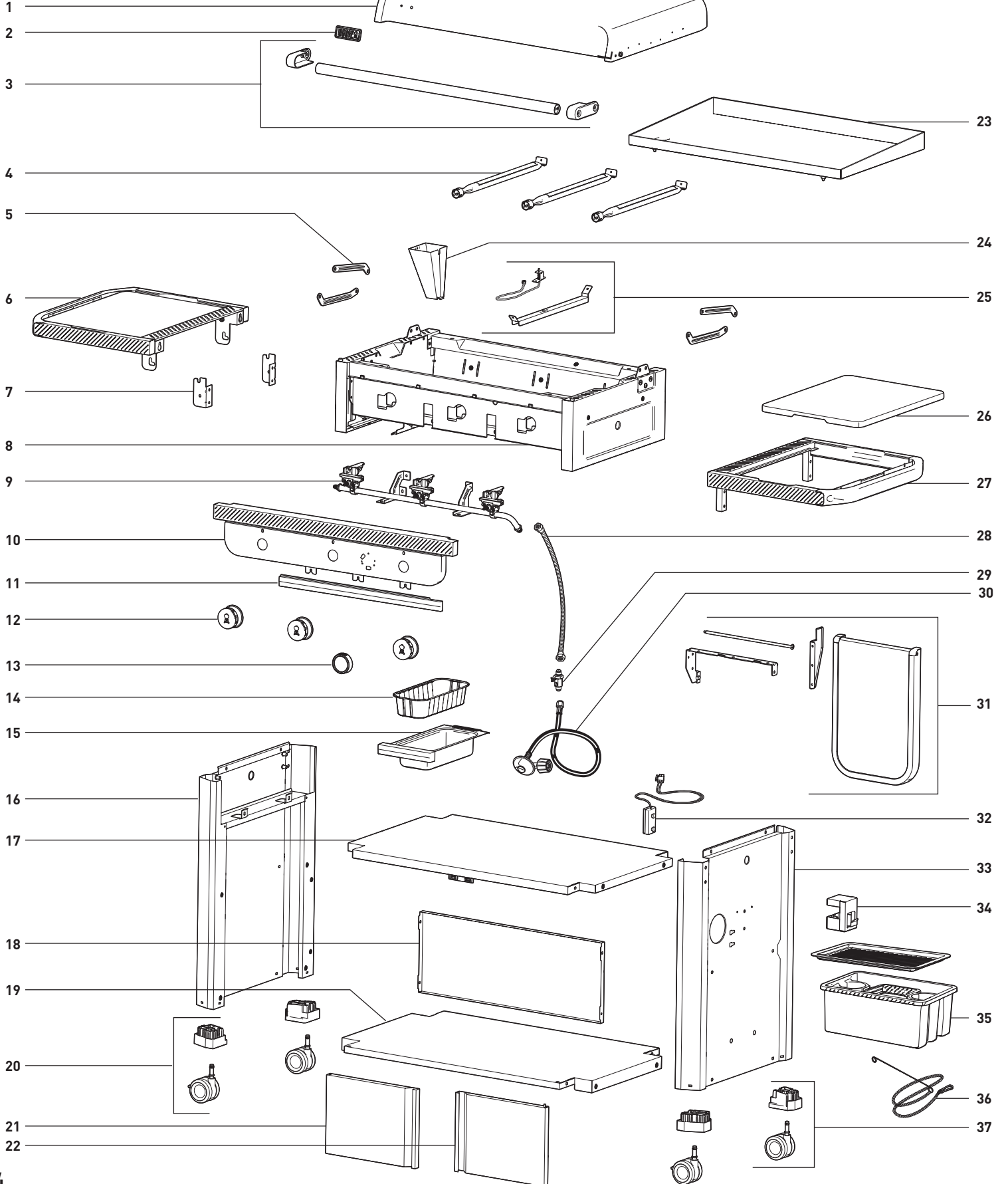

REPLACEMENT PARTS



SLATE - GPB30 LP - US - 031024

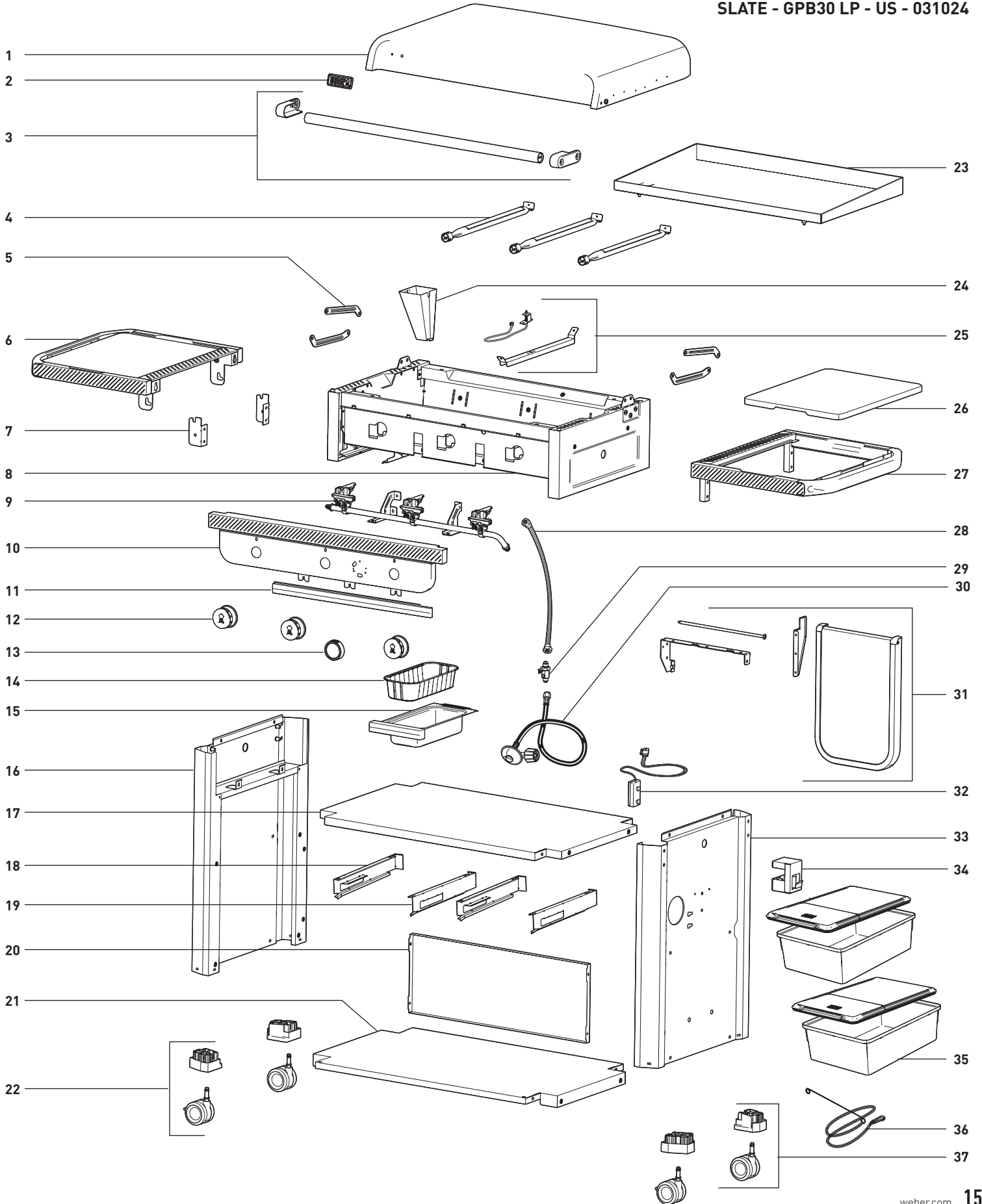



REPLACEMENT PARTS

SLATE - GPD36 LP - US - 090323

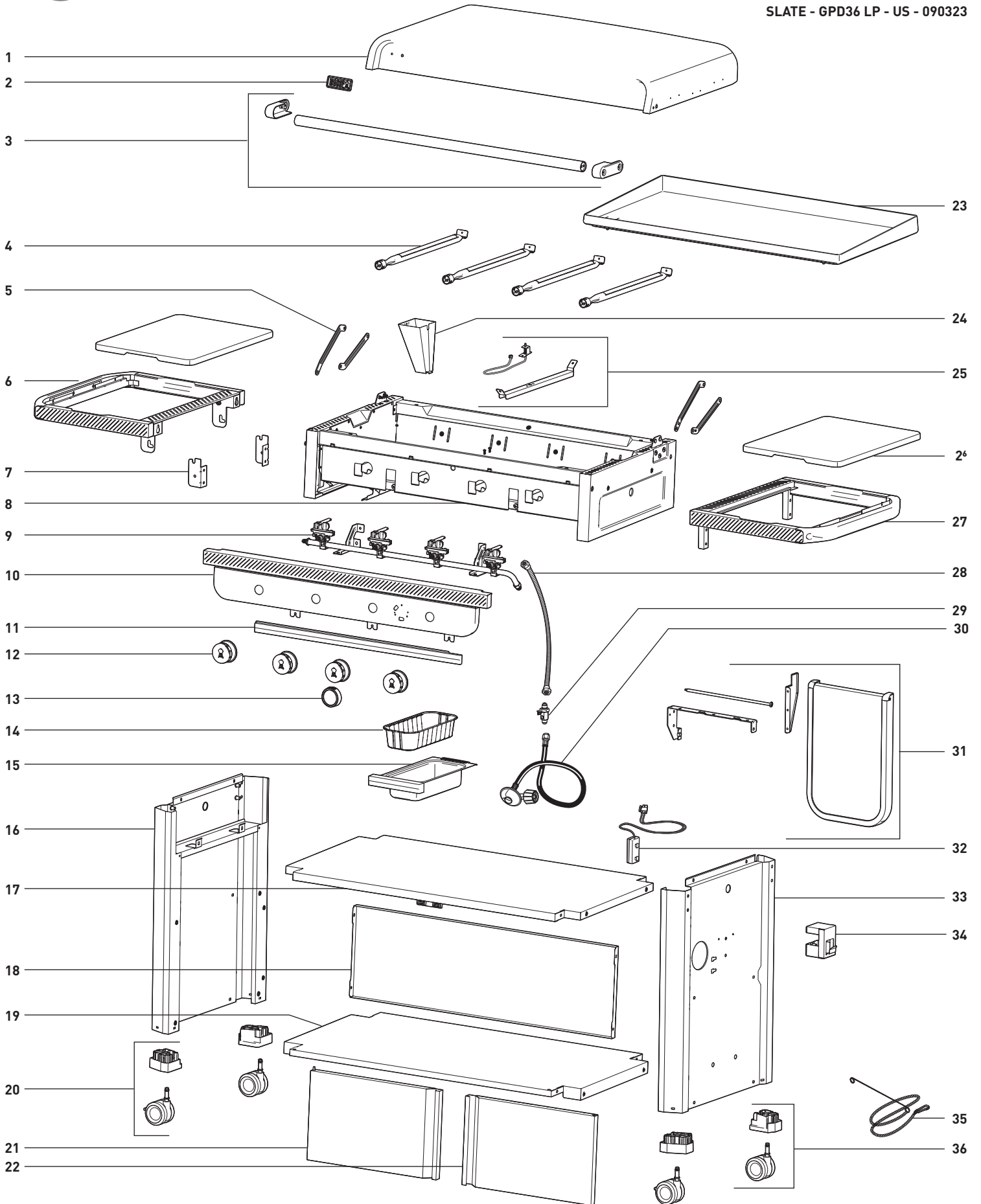

PROBLEMS? QUESTIONS? Do Not Return Product to the Store. We Can Help.

If you have questions about the assembly, use, or maintenance of your grill or need replacement parts, please contact Weber Customer Service. The serial number and model number can be found on the cover of your owner's manual and will be necessary for all service calls.

U.S.:

1-800-446-1071

Canada:

1-800-446-1071

Mexico:

01 800 0093237

© 2024 Designed and engineered by Weber-Stephen Products LLC, 1415 S. Roselle Road, Palatine, Illinois 60067 USA.